

Servomotors and Amplifiers

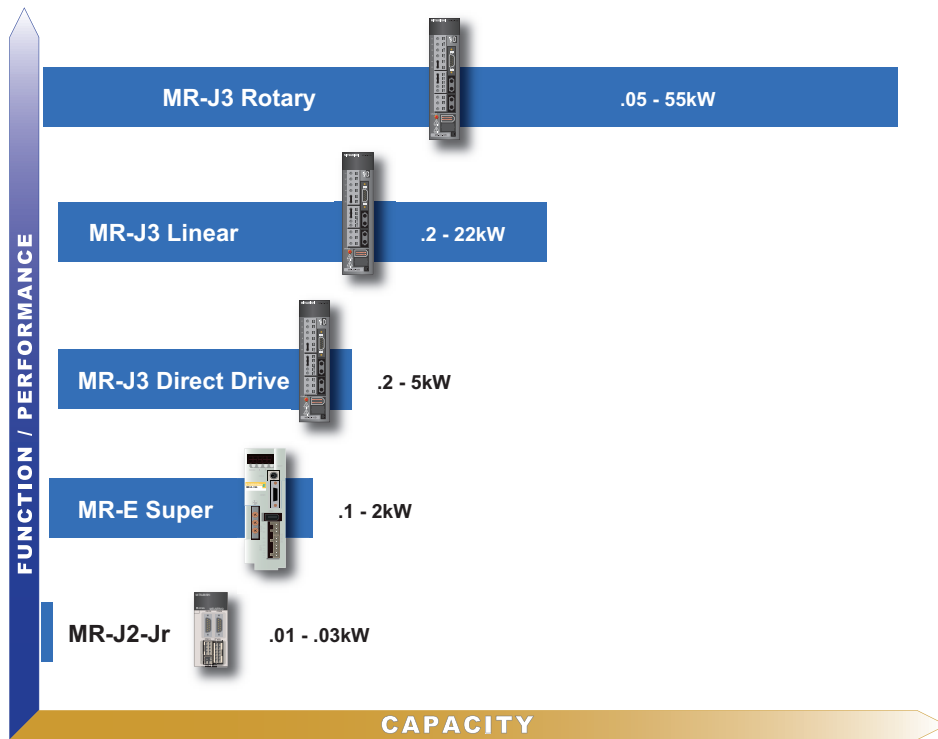

MR-J2-JR Rotary	238
MR-E Super Rotary	241
MR-J3 Rotary	253
MR-J3 Linear	312
MR-J3 Direct Drive Motor	326

Note: Refer to the Motion Controller section of this catalog for the MR-MQ100 Single Axis Motion Controller.

Stock Product: Stock product is product MEAU makes every effort to have on hand for immediate shipment. There may be instances when we are out of stock due to unexpected large requirements. All stock product will be indicated in this book by an “S” in the Stocked Item columns/rows.

Non-Stock Product: Non-stock product is product supplied on an “as-needed” basis. Standard lead times of 12 - 16 weeks apply, product is non-returnable and non-cancelable. Product listed as non-stock may change to stock product subject to increases in sales and usage. All non-stock product will be indicated in this book by a dash “-” in the Stocked Item columns/rows.

MR-J2-JR Servomotors and Amplifiers

The ultimate servo system using the latest in servo technology operating at 24VDC input with: patented Real-Time Adaptive Tuning; RS-232C serial interface for Windows based set-up speed, positioning, and torque modes; low acoustic noise and a built-in parameter unit.

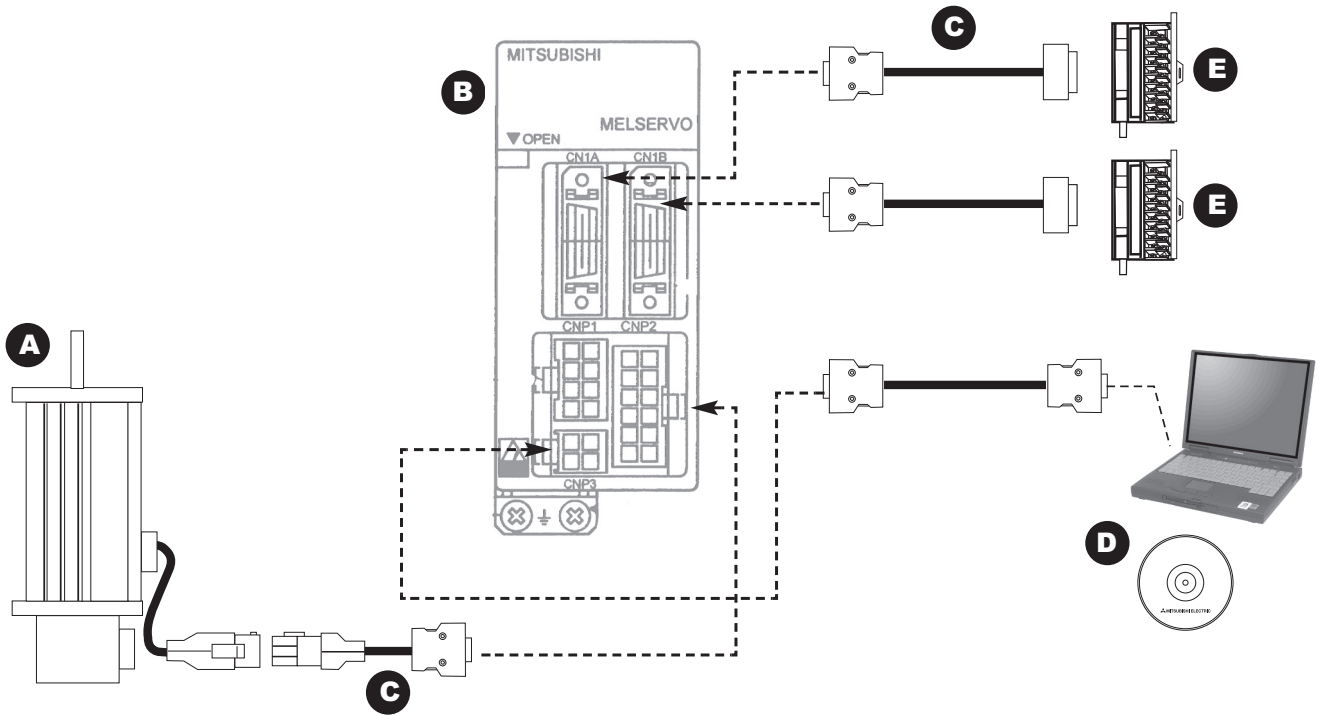

A. Motor	239
B. Amplifier	240
C. Cables	240
D. Software and Manuals	240
E. Optional Accessories	240

A MR-J2-JR Servomotors

Servomotor Selection

HC-AQ0 35 D

Symbol	Description
1	10 Watts
2	20 Watts
3	30 Watts

Symbol	Description
None	No brake installed
B	With an electromagnetic brake installed

Model Number		HC-AQ0135	HC-AQ0235	HC-AQ0335	
Stocked Item		-	-	S (Non-B only)	
Continuous Characteristics (*1, *2)	Rated Output	kW	0.01	0.02	0.03
	Rated Torque	N · m (oz · in)	0.0318 (4.503)	0.0637 (9.021)	0.0955 (13.524)
Rated Speed (*1)		r/min	3000		
Maximum Speed		r/min	5000		4500
Instantaneous Permissible Speed		r/min	5750		5175
Maximum Torque		N · m (oz · in)	0.0955 (13.524)	0.191 (27.048)	0.287 (40.643)
Power at Continuous Rated Torque		kW/s	2.0	5.6	9.7
Inertia Moment (*4)	J [x 10 ⁴ kg · m ²]		0.0050	0.0072	0.0094
	WK ² [oz · in ²]		0.027	0.039	0.051
Recommended Ratio of Load Inertia Moment to Servo Motor Shaft Inertia Moment		30 times or less			
Power Supply Capacity		Refer to "Power supply capacity and generated loss of servo amplifier" in the Servo Amplifier Instruction Manual			
Rated Current (Maximum Current)	A	2.4 (7.7)	2.4 (7.7)	2.3 (7.4)	
Speed/Position Detector		Encoder (resolution: 8192 pulses/rev)			
Accessory		Encoder			
Insulation Class		Class B			
Structure		Totally-enclosed self-cooling (protection type: IP55 (*6))			
Environmental Conditions (*5)		Refer to Section 2.1 in the Servo Motor Instruction Manual			
Weight (*3)	kg (lb)	0.19 (0.419)	0.22 (0.485)	0.25 (0.551)	

Notes:

- When the power supply voltage drops, we cannot guarantee the output and rated speed.
- 80% ED at low noise.
80% ED: Indicates the condition in which operation time at rated torque accounts for 80% and the other no load time accounts for 20% in a single operation cycle.
- When the servo motor is equipped with reduction gear or electromagnetic brake, refer to the corresponding outline dimension drawing. For the EN Standard and UL/cUL Standard compliant models, please contact Mitsubishi.
- If the load inertia moment ratio exceeds the indicated value, please contact Mitsubishi.
- When the equipment is to be used in places where it is subjected to oil and/or water, such as on machine field sites, optional features apply to the equipment.
- Except for the shaft-through portion and connector end.

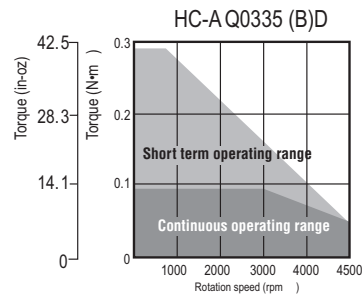
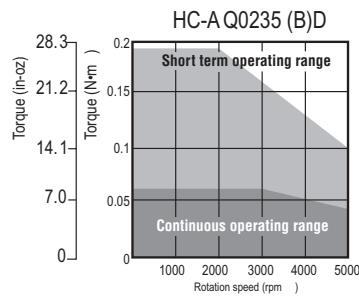
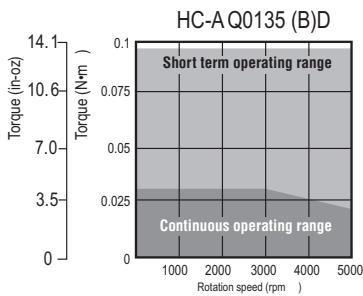

B MR-J2-JR Amplifiers

Amplifier Selection

MR-J2-03 5

Symbol	Description
A	Analog Speed, Analog Torque and Pulse Train Position
B	SSCNET high speed serial network
C	Built-in motion control (point table)

Model Number		MR-J2-03A5	MR-J2-03B5	MR-J2-03C5
Stocked Item		S	-	-
Circuit Power Supply (Note)	Voltage	21.6 to 30VDC (instantaneous permissible voltage 34V)		
	Power Supply Capacity	HC-AQ0135D	Continuous 0.8A, Max. 2.4A	
		HC-AQ0235D	Continuous 1.6A, Max. 4.8A	
	HC-AQ0335D	Continuous 2.4A, Max. 7.2A		
Control Circuit Power Supply (Note)		24VDC+10% 200mA (400mA when using the servo motor equipped with electromagnetic brake)		
System		Sine-wave PWM control, current control system		
Dynamic Brake		Built-in		
Protective Functions		Overcurrent shut-off, regenerative overvoltage shut-off, overload shut-off, (electronic thermal relay), servo motor overheat protection, encoder fault protection, undervoltage, instantaneous power failure protection, overspeed protection, excessive error protection		
Speed Frequency Response		250Hz or more		
Structure		Open (IP00)		
Environment	Ambient Temperature	Operation °C (°F)	0 to +55 (non-freezing) (32 to +131 (non-freezing))	
		Storage °C (°F)	-20 to +65 (non-freezing) (-4 to +149 (non-freezing))	
	Ambient Humidity	Operation (Storage) 90%RH or less (non-condensing)		
	Atmosphere	Indoors (no direct sunlight), Free from corrosive gas, flammable gas, oil mist, dust and dirt		
	Altitude	Max. 1000m (3280 ft) above sea level		
	Vibration	m/s ² (ft/s ²)	5.9 or less (19.4 or less)	
Weight	kg (lb)	0.2 (0.44)		

Note: To comply with the low voltage directive, use a reinforced insulation stabilizing power supply.

C Cables

Motor Type	Power/Encoder Cable Length	Power/Encoder Cable Model Number	Stocked Item
HC-AQ0135D or HC-AQ0135BD	2 Meter	MR-JRCBL2M-H	S
HC-AQ0135D or HC-AQ0135BD	5 Meter	MR-JRCBL5M-H	-
HC-AQ0135D or HC-AQ0135BD	10 Meter	MR-JRCBL10M-H	-
HC-AQ0235D or HC-AQ0235BD	2 Meter	MR-JRCBL2M-H	S
HC-AQ0235D or HC-AQ0235BD	5 Meter	MR-JRCBL5M-H	-
HC-AQ0235D or HC-AQ0235BD	10 Meter	MR-JRCBL10M-H	-
HC-AQ0335D or HC-AQ0335BD	2 Meter	MR-JRCBL2M-H	S
HC-AQ0335D or HC-AQ0335BD	5 Meter	MR-JRCBL5M-H	-
HC-AQ0335D or HC-AQ0335BD	10 Meter	MR-JRCBL10M-H	-

D Software

Description	Model Number	Stocked Item
Windows Communication Software	MR-CONFIGURATOR	S
Communication Cable	MR-JRPCATCBL3M	S

Manuals

Description	Model Number	Stocked Item
MR-J2-03A5 Instruction Manual	SH(NA)3200	meau.com
MR-J2-03B5 Instruction Manual	SH(NA)030005	meau.com
MR-J2-03C5 Instruction Manual	SH(NA)3209	meau.com
ServoMotor Instruction Manual	SH(NA)3181	meau.com

Note: Many of these manuals are available for free download from our website, www.meau.com

E System Options

Description	Model Number	Stocked Item
Terminal Block	MR-TB20	S
Terminal Block Cable 0.5 Meter	MR-J2TBL05M	S
Terminal Block Cable 1.0 Meter	MR-J2TBL1M	S
Encoder Connector Kit (instead of MR-JRCBL_M-H Cable)	MR-JRCNM	-
CN1-I/O Connector Kit (contains 2 connectors, one each for CN1A & CN1B)	MR-J2CN1	S
CN1-I/O Pigtail Cables (one each optional for CN1A & CN1B)	MR-CCN1CBL-3M (3m length) MR-CCN1CBL-5M (5m length)	S

MR-E Super Servomotors and Amplifiers

High performance and compact, the MR-E Super is an excellent choice for applications up to 2kW. The MR-E Super is available in pulse-train position or analog speed/torque models. The amplifier features Mitsubishi Electric's legendary auto-tuning and vibration suppression functions, a 400Hz analog frequency response, and accepts pulse commands up to 500kHz. The motors are low to medium inertia up to 4500rpm and are equipped with a 131,072 pulse per revolution encoder. Set-up and diagnosis is made easy with the MR-Configurator Windows® based software.

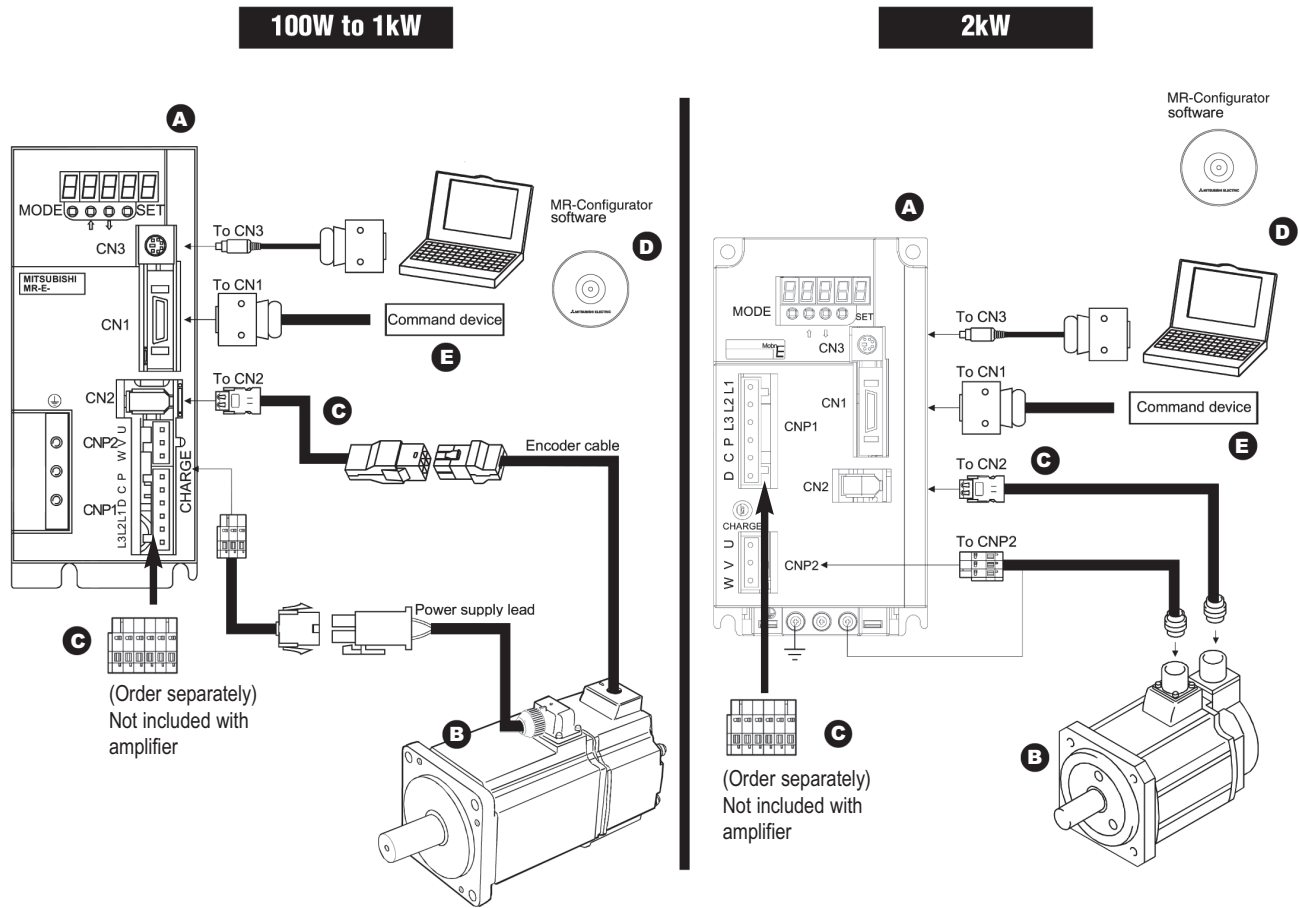

A. Amplifier	242
B. Motor	243
C. Cables / Connectors.....	246
D. Software and Manuals	249
E. Optional Accessories	249

A MR-E Super Amplifiers

Amplifier Selection

MR-E-□□-KH003

Super Series

Mitsubishi E-Series
general purpose AC
Servo Amplifier

Symbol	Description
A	General Pulse Train Interface
AG	Analog Input Interface

Symbol	Compatible Motor	
	HF-KE□(B)W1-S100	HF-SE□(B)JW1-S100
10	13	—
20	23	—
40	43	—
70	73	52
100	—	102
200	—	152, 202

Conforms to
the following
standards: EN,
UL, cUL

Servo Standard Specifications

Servo Amplifier Model		MR-E-10A-KH003	MR-E-20A-KH003	MR-E-40A-KH003	MR-E-70A-KH003	MR-E-100A-KH003	MR-E-200A-KH003	
		MR-E-10AG-KH003	MR-E-20AG-KH003	MR-E-40AG-KH003	MR-E-70AG-KH003	MR-E-100AG-KH003	MR-E-200AG-KH003	
Stocked Item		S	S	S	S	S	S	
Power Supply	Voltage/Frequency (*1)	3-phase 200 to 230VAC 50/60Hz or 1-phase 230VAC 50/60Hz				3-phase 200 to 230VAC 50/60Hz		
	Permissible Voltage Fluctuation	For 3-phase 200 to 230VAC: 3-phase 170 to 253VAC For 1-phase 230VAC: 1-phase 207 to 253VAC				3-phase 170 to 253VAC		
	Permissible Frequency Fluctuation	±5% maximum						
Control System		Sine-wave PWM control/current control system						
Dynamic Brake		Built-in						
Built-In Regenerative Resistor		None			Installed			
Safety Features		Overcurrent shutdown, regeneration overvoltage shutdown, overload shutdown (electronic thermal), encoder fault protection, regeneration fault protection, undervoltage/sudden power outage protection, overspeed protection, excess error protection						
A Type Amps	Position Control Mode	Maximum Input Pulse Frequency	1Mpps (when using differential receiver), 200 kpps (when using open collector)					
		Positioning Feedback Pulse	Resolution per encoder/servo motor rotation: 131072 p/rev					
		Command Pulse Multiple	Electronic gear A/B multiple, A: 1 to 65535, B: 1 to 65535, 1/50 < A/B < 50					
		Positioning Complete Width Setting	0 to ±10000 pulses (command pulse unit)					
		Excess Error	±2.5 rotations					
		Torque Limit	Set by parameters					
Speed Control Mode	Speed Control Mode	Speed Control Range	Internal speed command 1:5000					
		Speed Fluctuation Rate	±0.01% maximum (load fluctuation 0 to 100%) 0% (power fluctuation ±10%)					
		Torque Limit	Set by parameters					
AG Type Amps	Speed Control Mode	Speed Control Range	Analog speed command 1:2000, internal speed command 1:5000					
		Analog Speed Command Input	0 to ±10VDC / rated speed					
		Speed Fluctuation Rate	±0.01% maximum (load fluctuation 0 to 100%); 0% (power fluctuation ±10%) ±0.2% maximum (ambient temperature 25°C±10°C [59°F to 95°F]), when using analog speed command					
		Torque Limit	Set by parameters or external analog input (0 to +10VDC/maximum torque)					
	Torque Control Mode	Analog Torque Command Input	0 to ±8VDC/maximum torque (input impedance 10 to 12kΩ)					
Speed Limit		Set by parameters or external analog input (0 to ±10VDC/rated speed)						
Structure		Self-cooling open (IP00)					Fan cooling open (IP00)	
Environment	Ambient Temperature	0 to 55°C (32 to 131°F) (non-freezing), storage: -20 to 65°C (-4 to 149°F) (non-freezing)						
	Ambient Humidity	90% RH maximum (non-condensing), storage: 90% RH maximum (non-condensing)						
	Atmosphere	Indoors (no direct sunlight); no corrosive gas, inflammable gas, oil mist or dust						
	Elevation	1000m or less above sea level						
	Vibration	5.9m/s ² maximum						
Mass kg (lb)		0.7 (1.5)	0.7 (1.5)	1.1 (2.4)	1.7 (3.7)	1.7 (3.7)	2.0 (4.4)	

Note:

- Rated output and rated speed of a servo motor are applicable when the servo amplifier, combined with the servo motor, is operated within the specified power supply voltage and frequency. The torque drops when the power supply voltage is less than specified.

B MR-E Super Servomotors

Servomotor Selection

HF-KE 3 W1-S100

Super Series
Encoder Resolution 131,072 ppr (Inc)

Symbol	Shaft Shape
None	Standard (Straight Shaft)
K	With Keyway (Note)

Note: Keyway only on 200W ~ 750W with key included.

Symbol	Electromagnetic Brake
None	Without Brake
B	With Brake

Symbol	Rated Output (W)
1	100
2	200
4	400
7	750

Conforms to the following standards:
EN, UL, cUL

Rated Speed
3000 (r/min)

Stocked Motors

Model Number
HF-KE13W1-S100
HF-KE13BW1-S100
HF-KE23KW1-S100
HF-KE23BKW1-S100
HF-KE43KW1-S100
HF-KE43BKW1-S100
HF-KE73KW1-S100
HF-KE73BKW1-S100

HF-SE 2 J W1-S100

Super Series
Encoder Resolution 131,072 ppr (Inc)

Symbol	Shaft Shape
None	Standard (Straight Shaft)
K	With Keyway (Note)

Note: Key not included.

With Oil Seal Standard

Symbol	Electromagnetic Brake
None	Without Brake
B	With Brake



Symbol	Rated Output (W)
5	500
10	1000
15	1500
20	2000

Conforms to the following standards:
EN, UL, cUL

Rated Speed
2000 (r/min)

Stocked Motors

Model Number
HF-SE52JKW1-S100
HF-SE52BJKW1-S100
HF-SE102JKW1-S100
HF-SE102BJKW1-S100
HF-SE152JKW1-S100
HF-SE152BJKW1-S100
HF-SE202JKW1-S100
HF-SE202BJKW1-S100

	Motor Series	Rated Speed (Max. r/min)	Rated Output Capacity (kW)	Servomotor Brake (B)	EN	UL, cUL	Protective Rating	Features	Application Examples
Small Capacity	HF-KE Super Series 	3000 (4500)	4 Types 0.1, 0.2, 0.4, 0.75	Yes	Yes	Yes	IP55 Excluding the shaft-through portion and connector	Stable control from low speeds to high speeds allows compliance with a variety of applications.	Belt Drive; Robots; Mounters; Sewing Machines; X-Y Tables; Food Processing Machines
Medium Capacity	HF-SE Super Series 	2000 (3000)	4 Types 0.5, 1.0, 1.5, 2.0	Yes	Yes	Yes	IP65 Excluding the shaft-through portion		Material Handling Systems; Robots; X-Y Tables

MR-E HF-KE Super 3000 r/min Series Servomotor Specifications

Servo Motor Model	HF-KE13W1-S100	HF-KE23W1-S100	HF-KE43W1-S100	HF-KE73W1-S100
Servomotor Model with Brake	HF-KE13BW1-S100	HF-KE23BW1-S100	HF-KE43BW1-S100	HF-KE73BW1-S100
Compatible Servo Amplifier Model	MR-E-10A-KH003	MR-E-20A-KH003	MR-E-40A-KH003	MR-E-70A-KH003
Compatible Servo Amplifier with Analog Input Interface	MR-E-10AG-KH003	MR-E-20AG-KH003	MR-E-40AG-KH003	MR-E-70AG-KH003
Power Facility Capacity (kVA) (*1)	0.3	0.5	0.9	1.3
Continuous Running Duty	Rated Output (W)	100	200	400
	Rated Torque (N·m [oz·in])	0.32 (45.3)	0.64 (90.6)	1.3 (184)
Maximum Torque (N·m [oz·in])	0.95 (135)	1.9 (269)	3.8 (538)	7.2 (1020)
Rated Speed (r/min)	3000			
Maximum Speed (r/min)	4500			
Permissible Instantaneous Speed (r/min)	5175			
Power Rate At Continuous Rated Torque (kW/s)	11.5	16.9	38.6	39.9
Rated Current (A)	0.8	1.4	2.7	5.2
Maximum Current (A)	2.4	4.2	8.1	15.6
Regenerative Braking Frequency (Times/Min.) (*2, *3)	With No Options	(*4)	(*4)	249
	MR-RB032 (30W)	(*4)	(*4)	747
	MR-RB12 (100W)	-	(*4)	2490
	MR-RB32 (300W)	-	-	2100
Moment Of Inertia J (x10 ⁻⁴ kg · m ²) [J (oz · in ²)]	Standard	0.088 (0.481)	0.24 (1.31)	0.42 (2.30)
	With Electromagnetic Brake	0.090 (0.492)	0.31 (1.69)	0.50 (2.73)
Recommended Load/Motor Inertia Moment Ratio	Maximum of 15 times the servo motor's inertia moment (*5)			
Speed/Position Detector	Incremental encoder (resolution per servo motor rotation: 131072 p/rev)			
Attachments	-			
Structure	Totally enclosed non ventilated (protection level: IP55) (*6)			
Environment	Ambient Temperature	0 to 40°C (32 to 104°F) (non-freezing), storage: -15 to 70°C (5 to 158°F) (non-freezing)		
	Ambient Humidity	80% RH maximum (non-condensing), storage: 90% RH maximum (non-condensing)		
	Atmosphere	Indoors (no direct sunlight); no corrosive gas, inflammable gas, oil mist or dust		
	Elevation/Vibration (*7)	1000m or less above sea level; X: 49m/s ² Y: 49m/s ²		
Mass kg (lb)	Standard	0.56 (1.3)	0.94 (2.1)	1.5 (3.3)
	With Electromagnetic Brake	0.86 (1.9)	1.6 (3.6)	2.1 (4.7)

Notes:

- The power facility capacity varies depending on the power supply's impedance.
- The regenerative braking frequency shows the permissible frequency when the motor, without a load and the optional regeneration unit, decelerates from the rated speed to a stop. When a load is connected; however, the value will be the table value/(m+1), where m=the load inertia moment/the motor inertia moment. When the operating speed exceeds the rated speed, the regenerative braking frequency is inversely proportional to the square of (operating speed/rated speed). If the operating speed changes frequently or when the regeneration is constant (as with vertical feeds), find the regenerative heating value (W) in operation. Provisions must be made to keep this heating value below the tolerable regenerative power (W). Optimal regenerative resistor varies for each system. Refer to the section "Optional Accessories • Regenerative Brake Options" in this catalog for details on the tolerable regenerative power (W).
- The regenerative braking frequency of the 600W or smaller servo amplifier may fluctuate due to the affect of the power voltage since the energy charged by the electrolytic capacitor in the servo amplifier is large.
- There are no limits on regeneration frequency as long as the effective torque is within the rated torque range. However, the load/motor of inertia moment ratio must be 15 times or less.
- Contact Mitsubishi if the load/motor of inertia moment ratio exceeds the value in the table.
- The shaft-through portion and connector for cable terminal are excluded.
- The vibration direction is shown in the right-side diagram. The numeric value indicates the maximum value of the component (commonly the bracket in the opposite direction of the motor shaft). Fretting of the bearing occurs easily when the motor stops, so maintain vibration to approximately one-half of the allowable value.

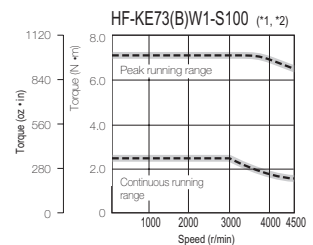
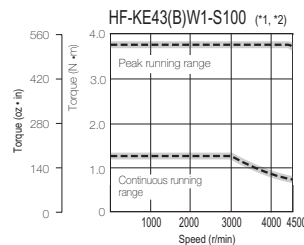
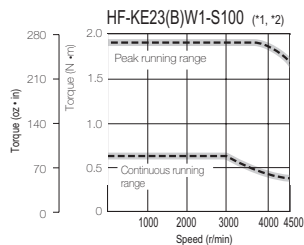
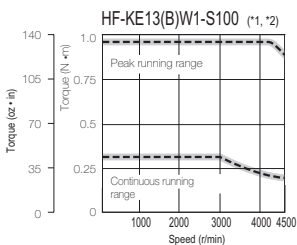

Notes:

- : For 3-phase 200VAC.
- - - : For 1-phase 230VAC.

MR-E HF-SE Super 2000 r/min Series Servomotor Specifications

Servo Motor Model		HF-SE52JW1-S100	HF-SE102JW1-S100	HF-SE152JW1-S100	HF-SE202JW1-S100
Servo Motor Model With Brake		HF-SE52BJW1-S100	HF-SE102BJW1-S100	HF-SE152BJW1-S100	HF-SE202BJW1-S100
Compatible Servo Amplifier Model		MR-E-70A-KH003	MR-E-100A-KH003	MR-E-200A-KH003	
Compatible Servo Amplifier with Analog Input Interface		MR-E-70AG-KH003	MR-E-100AG-KH003	MR-E-200AG-KH003	
Power Facility Capacity (kVA) (*1)		1.0	1.7	2.5	3.5
Continuous Running Duty	Rated Output (kW)	0.5	1.0	1.5	2.0
	Rated Torque (N·m [oz·in])	2.39 (338)	4.77 (675)	7.16 (1010)	9.55 (1350)
Maximum Torque (N·m [oz·in])		7.16 (1010)	14.3 (2020)	21.5 (3040)	28.6 (4050)
Rated Speed (r/min)		2000			
Maximum Speed (r/min)		3000			
Permissible Instantaneous Speed (r/min)		3450			
Power Rate At Continuous Rated Torque (kW/s)		9.34	19.2	28.8	23.8
Rated Current (A)		2.9	5.3	8.0	10
Maximum Current (A)		8.7	15.9	24	30
Regenerative Braking Frequency (Times / Min) (*2, *3)	With No Options	120	62	152	71
	MR-RB032 (30W)	180	93	-	-
	MR-RB12 (100W)	600	310	-	-
	MR-RB30 (300W)	-	-	456	213
	MR-RB32 (300W)	1800	930	-	-
Moment Of Inertia J (x10 ⁻⁴ kg·m ²) [J (oz·in ²)]	Standard	6.1 (33.4)	11.9 (65.1)	17.8 (97.3)	38.3 (209)
	With Electromagnetic Brake	8.3 (45.4)	14.0 (76.5)	20.0 (109)	47.9 (262)
Recommended Load / Motor Inertia Moment Ratio		Maximum of 15 times the servo motor's inertia moment (*4)			
Speed / Position Detector		Incremental encoder (resolution per servo motor: 131072 p/rev)			
Attachments		Oil seal			
Structure		Totally enclosed non ventilated (protection level: IP65) (*5)			
Environment	Ambient Temperature	0 to 40°C (32 to 104°F) (non-freezing), storage: -15 to 70°C (5 to 158°F) (non-freezing)			
	Ambient Humidity	80% RH maximum (non-condensing), storage: 90% RH maximum (non-condensing)			
	Atmosphere	indoors (no direct sunlight); no corrosive gas, inflammable gas, oil mist or dust			
	Elevation	1000m or less above sea level			
	Vibration (*6)	X, Y: 24.5m/s ²		X: 24.5m/s ² • Y: 49m/s ²	
Mass kg (lb)	Standard	4.8 (11)	6.5 (15)	8.3 (19)	12 (27)
	With Electromagnetic Brake	6.7 (15)	8.5 (19)	11 (25)	18 (40)

Notes:

- The power facility capacity varies depending on the power supply's impedance
- The regenerative braking frequency shows the permissible frequency when the motor, without a load and the optional regeneration unit, decelerates from the rated speed to a stop. When a load is connected; however, the value will be the table value/(m+1), where m—the load inertia moment/the motor inertia moment. When the operating speed exceeds the rated speed, the regenerative braking frequency is inversely proportional to the square of (operating speed/rated speed). If the operating speed changes frequently or when the regeneration is constant (as with vertical feeds), find the regenerative heating value (W) in operation. Provisions must be made to keep this heating value below the tolerable regenerative power (W). Optional regenerative resistor varies for each system. Refer to the section "Optional Accessories • Regenerative Brake Options" in this catalog for details on the tolerable regenerative power (W).
- The regenerative braking frequency of the 600W or smaller servo amplifier may fluctuate due to the affect of the power voltage since the energy charged by the electrolytic capacitor in the servo amplifier is large
- Contact Mitsubishi if the load/motor of inertia moment ratio exceeds the value in the table
- The shaft-through portion is excluded.
- The vibration direction is shown in the right-side diagram. The numeric value indicates the maximum value of the component (commonly the bracket in the opposite direction of the motor shaft). Fretting of the bearing occurs easily when the motor stops, so maintain vibration to approximately one-half of the allowable value.

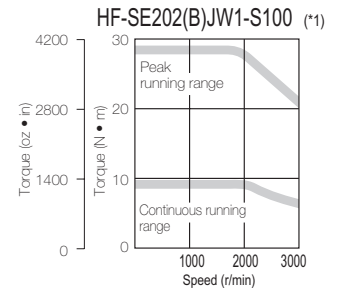
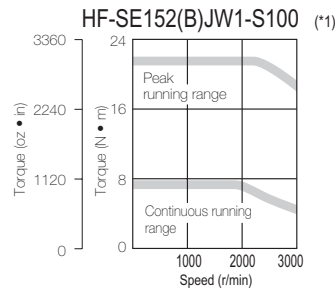
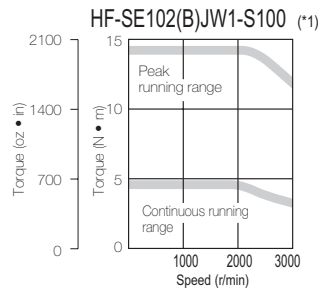
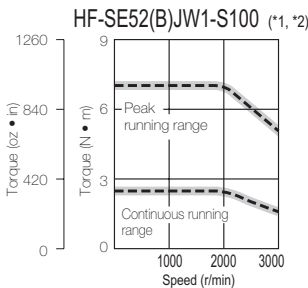

Notes:

- : For 3-phase 200VAC.
- - - : For 1-phase 230VAC.

G Cables and Connectors

HF-KE (B)W1-S100 Series: Encoder cable length 10m or shorter

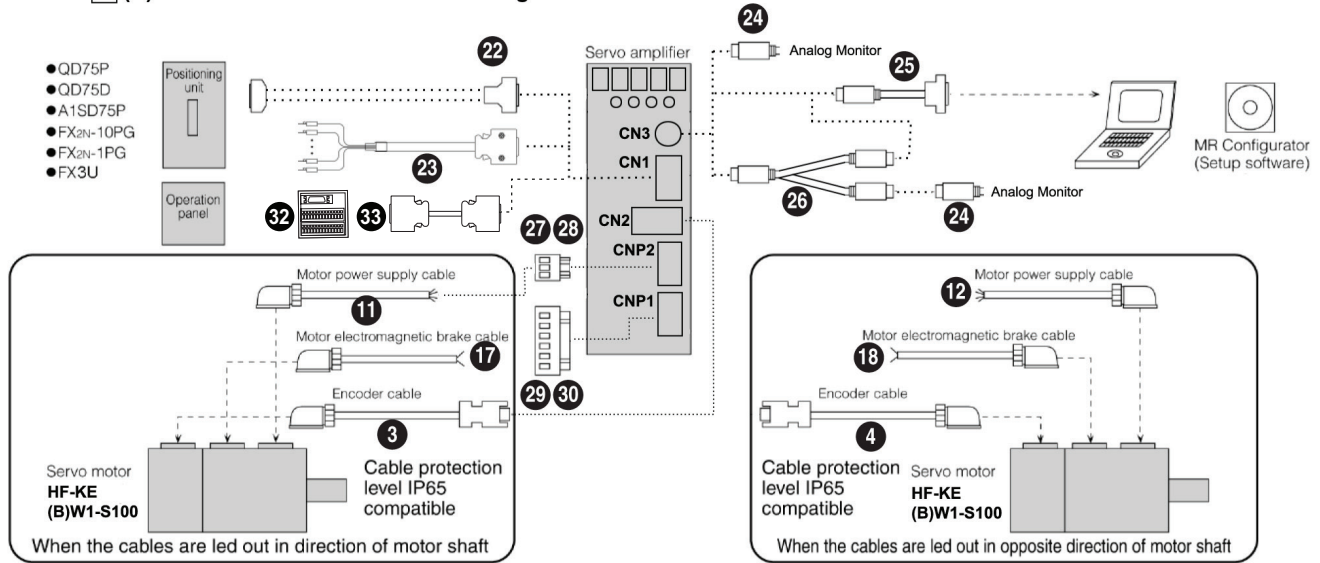

HF-KE (B)W1-S100 Series: Encoder cable length over 10m

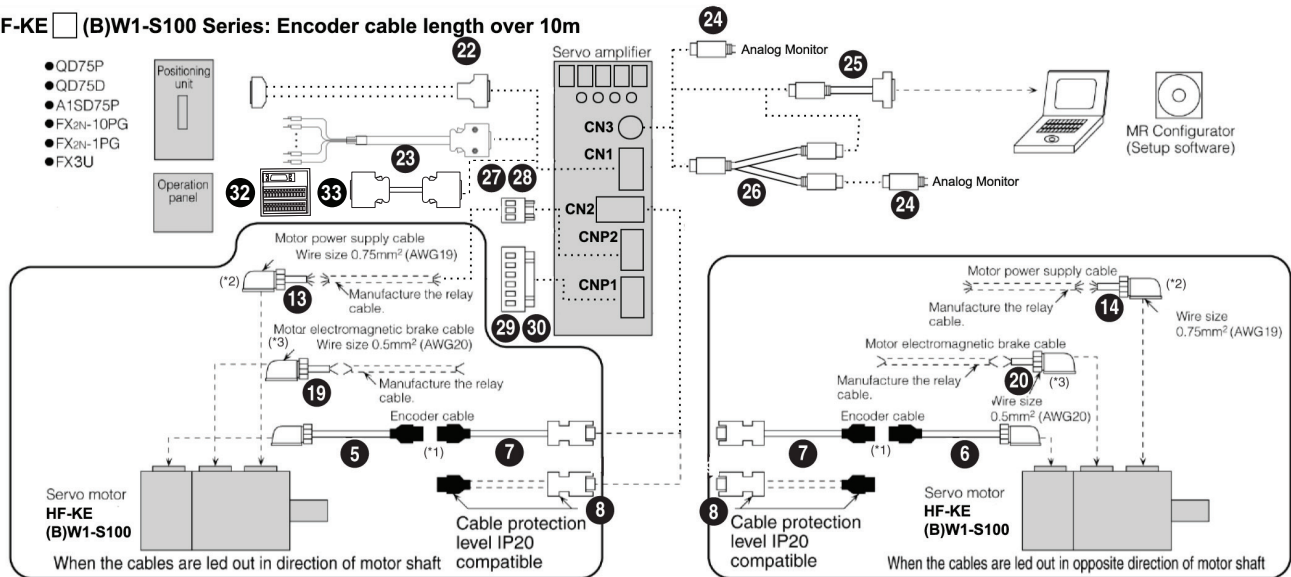

Notes: 1. This cable does not have a long bending life, please be sure to secure the cable before using.
 2. If the length exceeds 10m, use the needed length extension cable (customer supplied) in junction with the MR-PWS2CBL03M-A1-L/A2-L. This cable does not have a long bending life, please be sure to secure the cable before using.
 3. If the length exceeds 10m, use the needed length extension cable (customer supplied) in junction with the MR-BKS2CBL03M-A1-L/A2-L. This cable does not have a long bending life, please be sure to secure the cable before using.

HF-SE (B)JW1-S100 Series

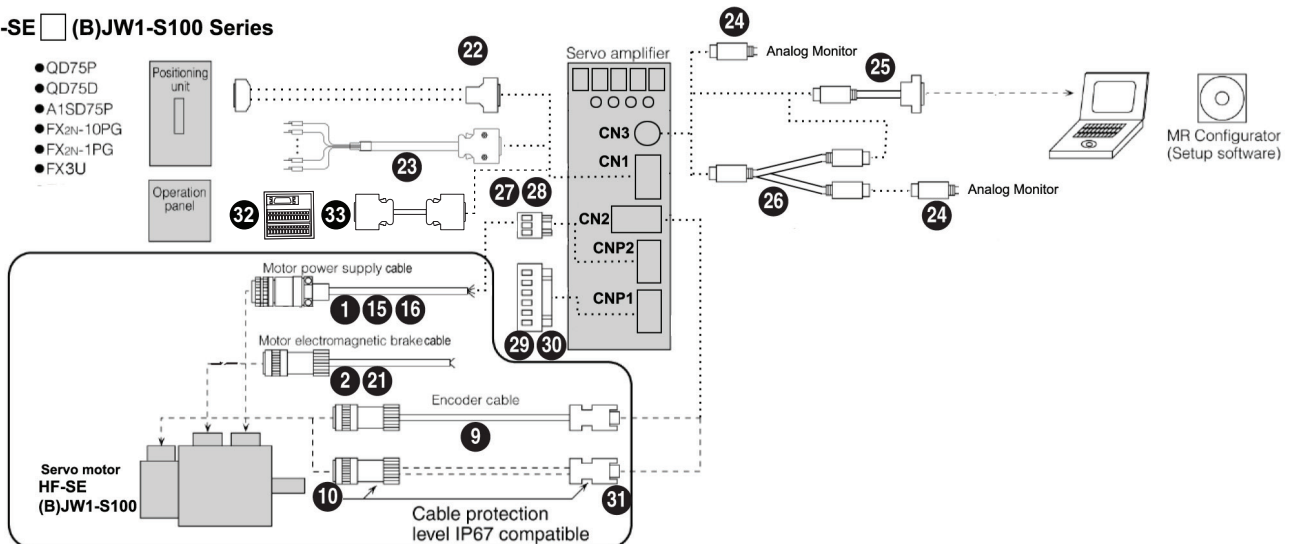

MR-E Super Cables and Connectors (refer to chart on previous page)

Power Cables for HF-SE_(B)JW1-S100

Item		Model Number (=cable length 2, 5, 10, 15, 20, 25, 30 meter)	Stocked Lengths	Protection Level	Diagram	
①	Standard-Flex, Unshielded Type Cables (Straight Type Connector Only)	HF-SE52(B)JW1-S100 (*1)	MR-J3P1-_M (*2)	2M, 5M, 10M, 20M, 30M	IP65	
		HF-SE102(B)JW1-S100 (*1)	MR-J3P2-_M (*2)			
		HF-SE152(B)JW1-S100 (*1)	MR-J3P3-_M (*2)			
		HF-SE202(B)JW1-S100 (*1)	MR-J3P4-_M (*2)			
	High-Flex, Shielded Type Cables (Straight Type Connector Only)	HF-SE52(B)JW1-S100 (*1)	MR-J3PWS1-_M (*2)	-	IP67	
		HF-SE102(B)JW1-S100 (*1)	MR-J3PWS2-_M (*2)			
		HF-SE152(B)JW1-S100 (*1)	MR-J3PWS3-_M (*2)			
		HF-SE202(B)JW1-S100 (*1)	MR-J3PWS4-_M (*2)			

Notes:

1. Must order separate brake cable for these motors.
2. Must order separate power connector 27 or 28 to connect to the power cable.

Brake Cables for HF-SE_BJW1-S100

Item		Model Number (=cable length 2, 5, 10, 15, 20, 25, 30 meter)	Stocked Lengths	Protection Level	Diagram
②	Standard-Flex, Unshielded Type Cables	MR-J3BK-_M	2M, 5M, 10M, 20M, 30M	IP65	
	High-Flex, Shielded Type Cables	MR-J3BK-_M	-	IP65	

Encoder Cables for CN2 Connector for HF-KE_(B)W1-S100

Item		Model Number (=cable length in meters)	Stocked Lengths	Protection Level	Diagram		
③	10m or Shorter (Direct Connection Type)	Lead Out in Direction of Motor Shaft	MR-J3ENCBL_M-A1-H = 2, 5 or 10 (*1)	2, 5, 10	IP65		
			MR-J3ENCBL_M-A1-L = 2, 5, or 10 (*1)	2, 5, 10	IP65		
④		Lead Out in Opposite Direction of Motor Shaft	MR-J3ENCBL_M-A2-H = 2, 5, or 10 (*1)	2, 5, 10	IP65		
			MR-J3ENCBL_M-A2-L = 2, 5, or 10 (*1)	2, 5, 10	IP65		
⑤		Lead Out in Direction of Motor Shaft	MR-J3JCBLO3M-A1-L cable length 0.3 (*1)	S	IP20		
⑥		Lead Out in Opposite Direction of Motor Shaft	MR-J3JCBLO3M-A2-L cable length 0.3 (*1)	S	IP20		
⑦	Exceeding 10m (Relay Type)	Amplifier-Side Cable	MR-EKCBL_M-H = 20, 30, 40, or 50 (*1)	20, 30	IP20		
			MR-EKCBL_M-L = 20 or 30 (*1)	-	IP20		
⑧		Junction Connector, Amplifier-Side Connector	MR-ECNM	S	IP20		

Note:

1. -H and -L indicate bending life. -H indicates a long bending life and -L indicates a standard bending life.

Encoder Cable for CN2 Connector for HF-SE_(B)JW1-S100

Item		Model Number (=cable length in meters)	Stocked Lengths	Protection Level	Diagram
⑨	Encoder Cable	MR-ENECBL_M-H (= 2, 5, 10, 20, 30, 40, or 50 (*1))	2, 5, 10	IP67	
⑩	Encoder Connector Set	MR-ENECNS	S	IP67	

Note:

1. -H and -L indicate bending life. -H indicates a long bending life and -L indicates a standard bending life.

Motor Power Supply Cables for CNP2 for HF-KE_(B)W1-S100

Item		Model Number (=cable length in meters)	Stocked Lengths	Protection Level	Diagram	
⑪	10m or Shorter (Direct Connection Type)	Lead Out in Direction of Motor Shaft	MR-PWS1CBL_M-A1-H = 2, 5 or 10 (*1, *2)	2, 5, 10	IP65	
			MR-PWS1CBL_M-A1-L = 2, 5 or 10 (*1, *2)	2, 5, 10	IP65	
⑫		Lead Out in Opposite Direction of Motor Shaft	MR-PWS1CBL_M-A2-H = 2, 5 or 10 (*1, *2)	2, 5, 10	IP65	
			MR-PWS1CBL_M-A2-L = 2, 5 or 10 (*1, *2)	2, 5, 10	IP65	
⑬	Exceeding 10m (Relay Type)	Lead Out in Direction of Motor Shaft	MR-PWS2CBL03M-A1-L cable length 0.3 (*2)	S	IP55	
⑭		Lead Out in Opposite Direction of Motor Shaft	MR-PWS2CBL03M-A2-L cable length 0.3 (*2)	S	IP55	

Notes:

1. Must order separate power connector 27 or 28 to connect to the power cable.
2. -H and -L indicate bending life. -H indicates a long bending life and -L indicates a standard bending life.

Power Supply Connectors

Item	Model Number	Stocked Lengths	Protection Level	Diagram	
15	Motors: HF-SE52(B)JW1-S100; HF-SE102(B)JW1-S100; HF-SE152(B)JW1-S100 (see 1 for the power cable)	MR-PWCNS4 (straight type only)	S	IP67	
16	Motor: HF-SE202(B)JW1-S100 (see 1 for the power cable)	MR-PWCNS5 (straight type only)	S	IP67	

Motor Brake Cables for HF-KE_BW1-S100

Item	Model Number (=cable length in meters)	Stocked Lengths	Protection Level	Diagram		
17	10m or Shorter (Direct Connection Type)	Lead Out in Direction of Motor Shaft	MR-BKS1CBL_M-A1-H = 2, 5, or 10 (*1)	2, 5, 10	IP65	
			MR-BKS1CBL_M-A1-L = 2, 5, or 10 (*1)	-	IP65	
18	10m or Shorter (Direct Connection Type)	Lead Out in Opposite Direction of Motor Shaft	MR-BKS1CBL_M-A2-H = 2, 5, or 10 (*1)	2, 5, 10	IP65	
			MR-BKS1CBL_M-A2-L = 2, 5, or 10 (*1)	-	IP65	
19	Exceeding 10m (Relay Type)	Lead Out in Direction of Motor Shaft	MR-BKS2CBL03M-A1-L cable length 0.3 (*1)	S	IP55	
20	Exceeding 10m (Relay Type)	Lead Out in Opposite Direction of Motor Shaft	MR-BKS2CBL03M-A2-L cable length 0.3 (*1)	S	IP55	

Note:

1. -H and -L indicate bending life. -H indicates a long bending life and -L indicates a standard bending life.

Brake Connector Set for HF-SE_BJW1-S100

Item	Model Number	Stocked Lengths	Protection Level	Diagram	
21	Brake Connector (see 2 for the brake cable)	MR-BKCNS1 (straight type only)	S	IP67	

Connector for CN1 on Amp

Item	Model Number	Stocked Lengths	Protection Level	Diagram	
22	CN1 Connector (26 pin)	MR-ECN1	S	-	

Pigtail Cable for CN1 on Amp

Item	Model Number	Stocked Lengths	Protection Level	Diagram	
23	CN1 Pigtail Cable (26 pin)	MR-ECN1CBL-3M	S	-	

Connector and Cable Options for CN3 Connector on Amp

Item	Model Number	Stocked Lengths	Protection Level	Diagram	
24	Analog Monitor RS-232C Connector	MR-ECN3	S	-	
25	Communication Cable	SC-Q	S	-	
26	Analog Monitor RS-232C Branch Cable	MR-E3CBL15-P	S	-	

CNP2 Power to Motor Connector

Item	Model Number	Stocked Lengths	Protection Level	Diagram	
27	MR-E10 to 100A/AG-KH003	MR-ECNP2-B	S	-	
28	MR-E200A/AG-KH003 Amp Only	MR-ECNP2-B1	S	-	

CNP1 Amp Power Input Connector

Item	Model Number	Stocked Lengths	Protection Level	Diagram	
29	MR-E10 to 100A/AG-KH003 Amps	MR-ECNP1-B	S	-	
30	MR-E200A/AG-KH003 Amp Only	MR-ECNP1-B1	S	-	

CN2 Connector

Item	Model Number	Stocked Lengths	Protection Level	Diagram
③1 CN2 Connector Only	MR-J3CN2	S	-	

For CN1

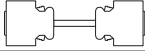
Item	Model Number	Stocked Lengths	Protection Level	Diagram
③1 Junction Terminal Block	MR-TB26A	S	-	
③2 Junction Terminal Block Cable	MR-TBNATBL_M _cable length: 0.5, 1m	0.5, 1	-	

D Software and Manuals

MR-Configurator Setup Software

This Windows® based software package is used to setup, program and test the amplifier. Initial setup and programming is easy and quick with the user-friendly software, which has extensive help functions and drop-downs. MR-Configurator also has many diagnostic functions such as a machine simulator to aid in mechanical design, a machine analyzer to find resonant frequencies of the load and set notch filters, an alarm monitor with history data, and the ability to assign and monitor I/O.

Features:

- Can be set up using a personal computer. Works on Windows 95/98/NT/ME/2000 Professional, XP Professional*.
- Provides numerous monitor functions. Provides graph display function that enables display of servomotor status upon input signal triggers such as command pulses, droop pulses, and r/min.
- Allows servomotors to be tested easily from a personal computer.

* Windows is a registered trademark of the Microsoft Corporation.

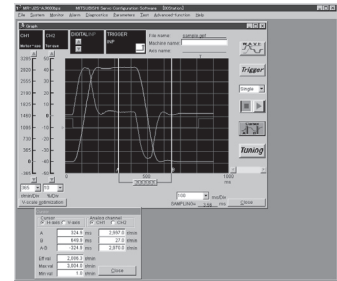

Description	Model Number	Stock Item
Windows Communication Software	MR-CONFIGURATOR	S
Communications Cable	SC-Q	S

Manuals

Hardware Description	Model Number	Stock Item
MR-E Super	SH(NA)030071	-
EMC Guidelines (Servo) Manual	IB(NA)67310	-

Note: Many of these manuals are available for free download from our website, www.meau.com

E Optional Accessories

Filters

Description	Model Type	Model Number	Stocked Item
Line Noise Filter	All MR-E Models	FR-BSF01	S
Radio Noise Filter	All MR-E Models	FR-BIF	S
EMC Filter	MR-E-10 to 100	SF1252	S
EMC Filter	MR-E-200	MF-3F480-025.230	-

Regenerative Brake Options

Servo Amplifier	Model Number - Regenerative Power [W]					
	Built-In Regen. Resistor	MR-RB032 [40Ω]	MR-RB12 [40Ω]	MR-RB30 [40Ω]	MR-RB32 [40Ω]	MR-RB50 [40Ω] (Note)
Stocked Item	N/A	S	S	S	S	S
MR-E-10	-	30	-	-	-	-
MR-E-20	-	30	100	-	-	-
MR-E-40	10	30	100	-	-	-
MR-E-70	20	30	100	-	300	-
MR-E-100	20	30	100	-	300	-
MR-E-200	100	-	-	300	-	500

Note: Always install a cooling fan when using MR-RB50.

AC Power Improving Reactor Options

Model Type	Model Number	Stocked Item
MR-E-10 to 40	MRL-00402	S
MR-E-70	MRL-00802	S
MR-E-100	MRL-01202	S
MR-E-200	MRL-01802	S

MR-E Super Shaft Detail

HF-KE_(B)W1-S100: With key (200, 400, 750W)

Model Number (*1)	Variable Dimensions								
	T	S	R	Q	W	QK	QL	U	Y
HF-KE23(B)KW1-S100 HF-KE43(B)KW1-S100	5	14h6	30	27	5	20	3	3	M4 screw Depth: 15mm
HF-KE73(B)KW1-S100	6	19h6	40	37	6	25	5	3.5	M5 screw Depth: 20mm

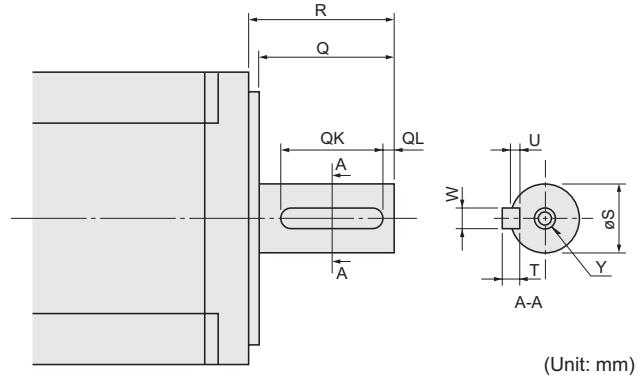

HF-KE13(B)DW1-S100: D-cut (100W) (*1)

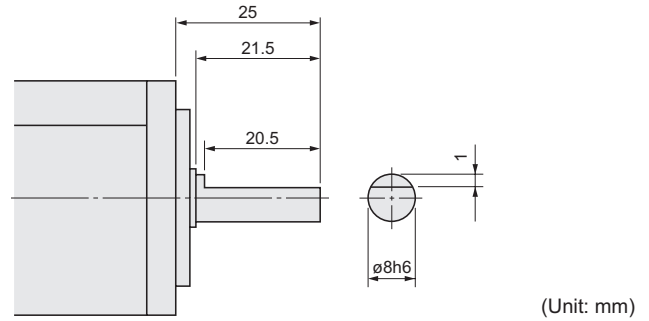

HF-SE_(B)JW1-S100: Key way - Key not included

Model Number (*1, *2)	Variable Dimensions								
	S	R	Q	W	QK	QL	U	r	Y
HF-SE52(B)JKW1-S100 HF-SE102(B)JKW1-S100 HF-SE152(B)JKW1-S100	24h6	55	50	8 ⁰ _{+0.036}	36	5	4 ^{+0.2} ₀	4	M8 screw Depth: 20mm
HF-SE202(B)JKW1-S100	35 ^{+0.01} ₀	79	75	10 ⁰ _{+0.036}	55	5	5 ^{+0.2} ₀	5	M8 screw Depth: 20mm

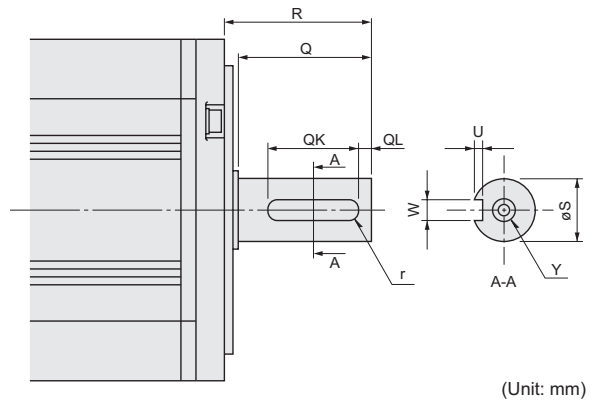

Notes:

- Motors with keyway shaft (with/without key) and D-cut shaft cannot be used in frequent start/stop applications. Loose keys may damage the motor shaft.
- A key is not supplied with the motor. The key shall be installed by the user.

Optional Keys Available (Order Separately)

Motor Model	Model Number	Key Dimensions	Stocked item
HF-SE52-152(B)JKW1-S100	MTR KEY 8-7-28	8 x 7 x 28	S
HF-SE202(B)JKW1-S100	MTR KEY 10-8-45	10 x 8 x 45	S

HF-KE Super Series

HF-KE13(B)W1-S100

(Unit: mm)

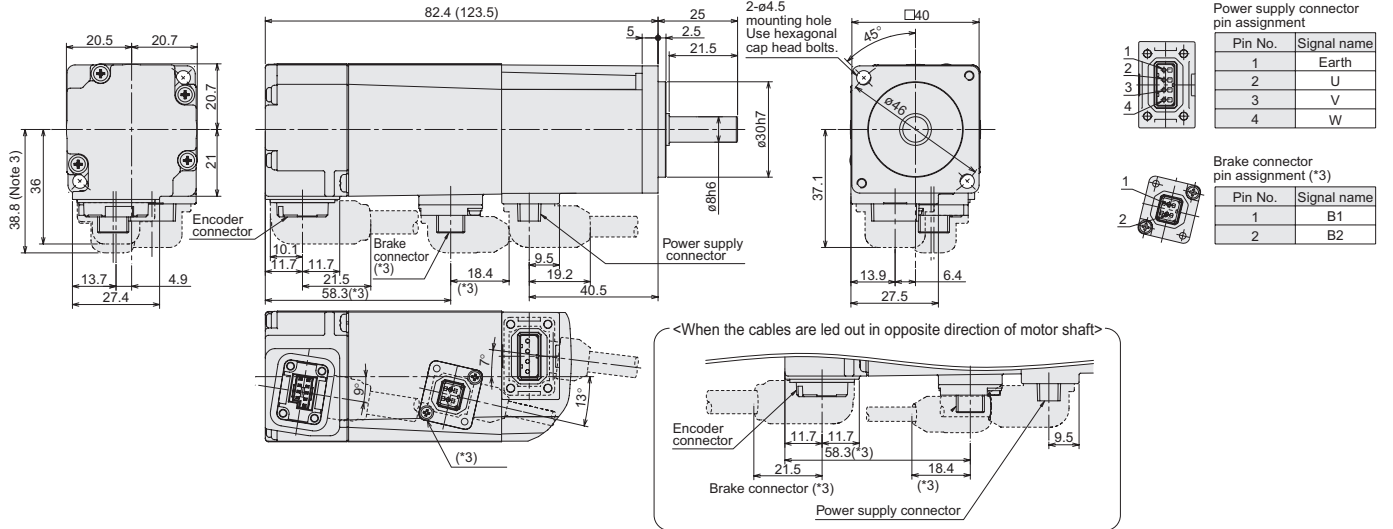

HF-KE23(B)W1-S100, HF-KE43(B)W1-S100

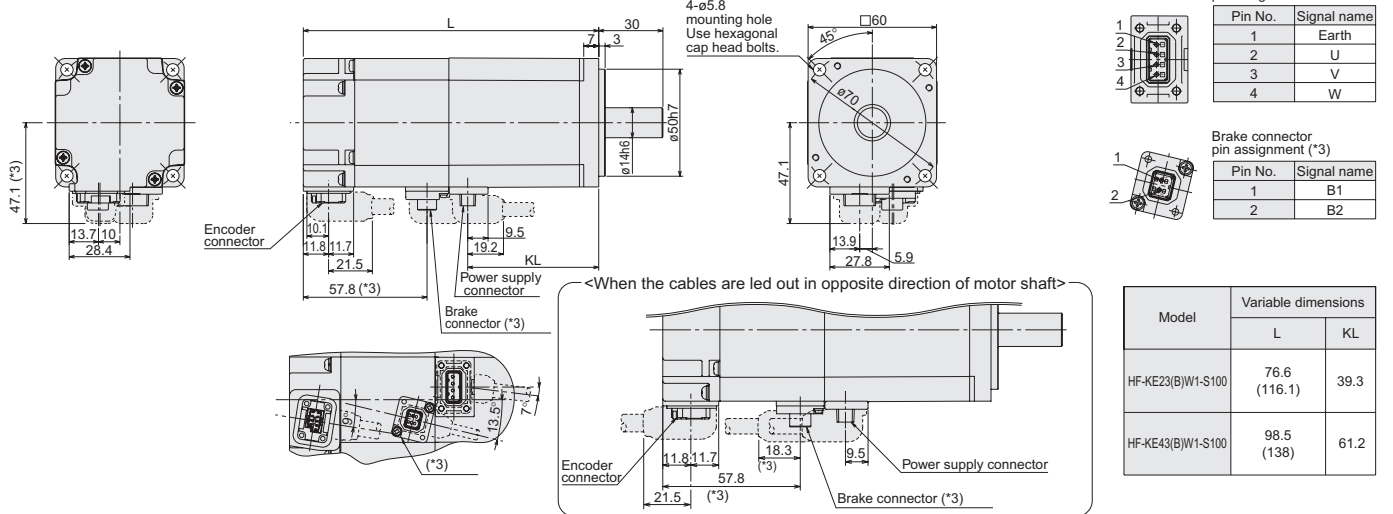

HF-KE73(B)W1-S100

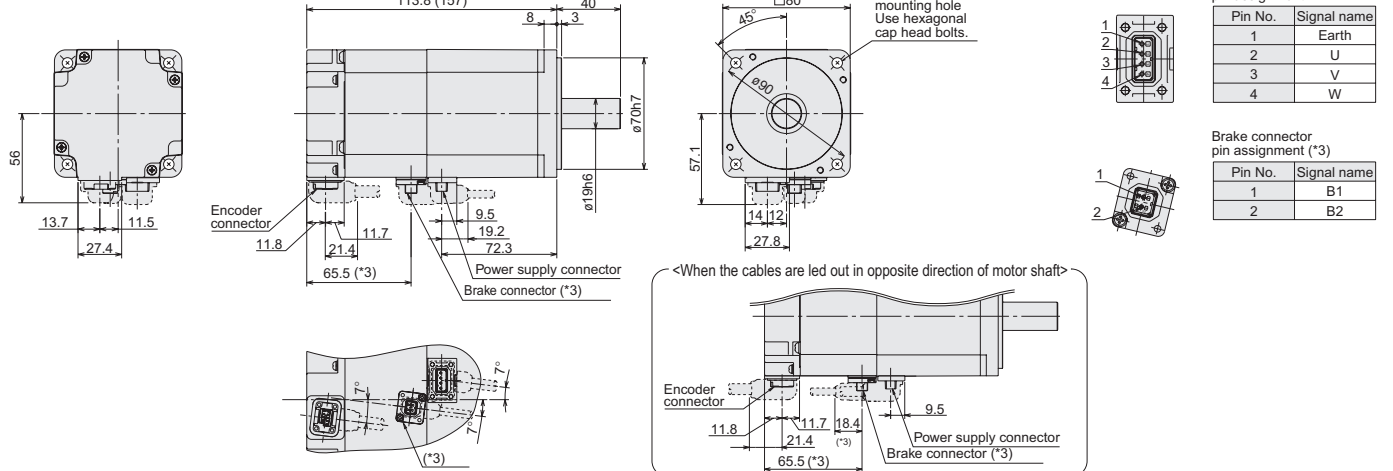

Notes:

1. Use a friction coupling to fasten a load.
2. Dimensions inside () are for the models with an electromagnetic brake.
3. Only for the models with an electromagnetic brake. The electromagnetic brake terminals (B1, B2) do not have polarity.
4. For dimensions where there is no tolerance listed, use general tolerance.

HF-SE Super Series

HF-SE52(B)JW1-S100, HF-SE102(B)JW1-S100, HF-SE152(B)JW1-S100

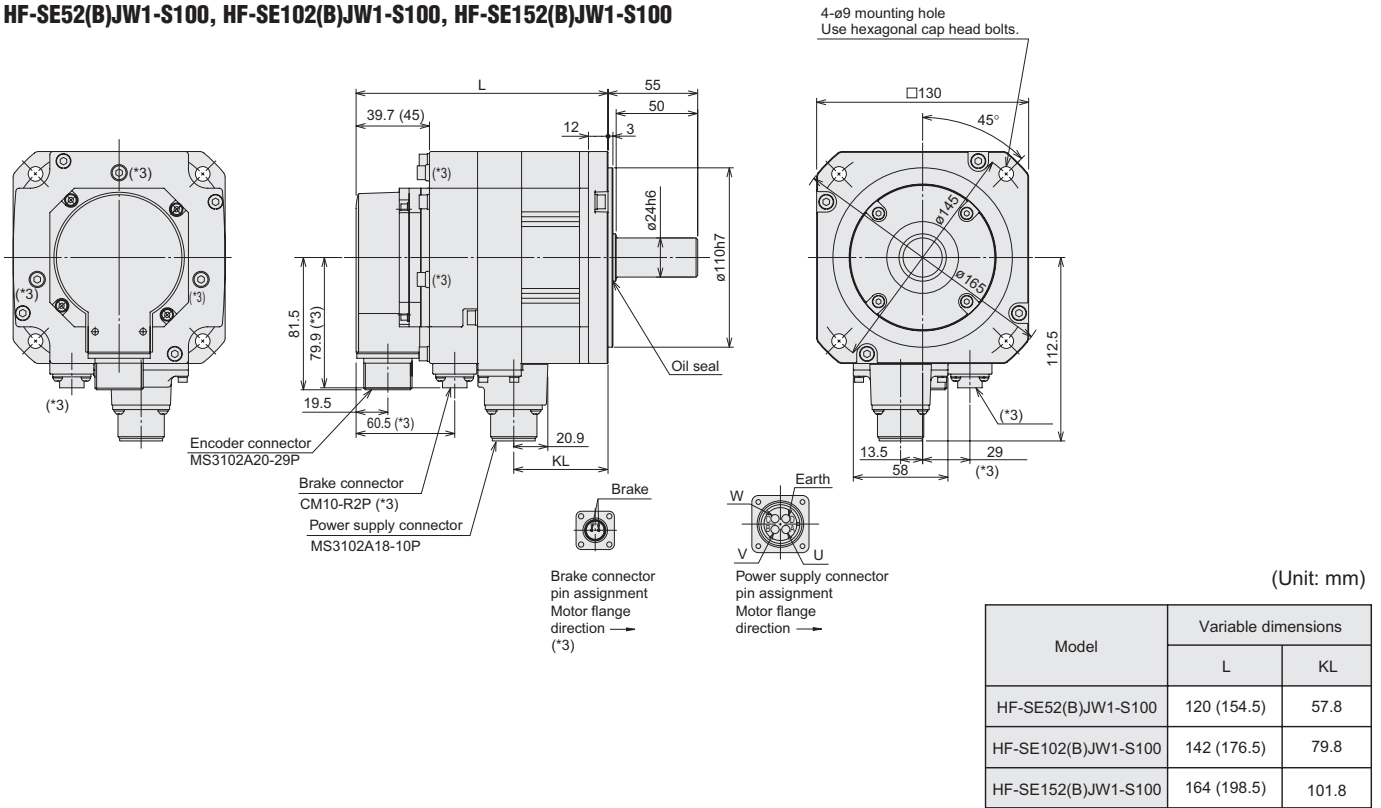

HF-SE202(B)JW1-S100

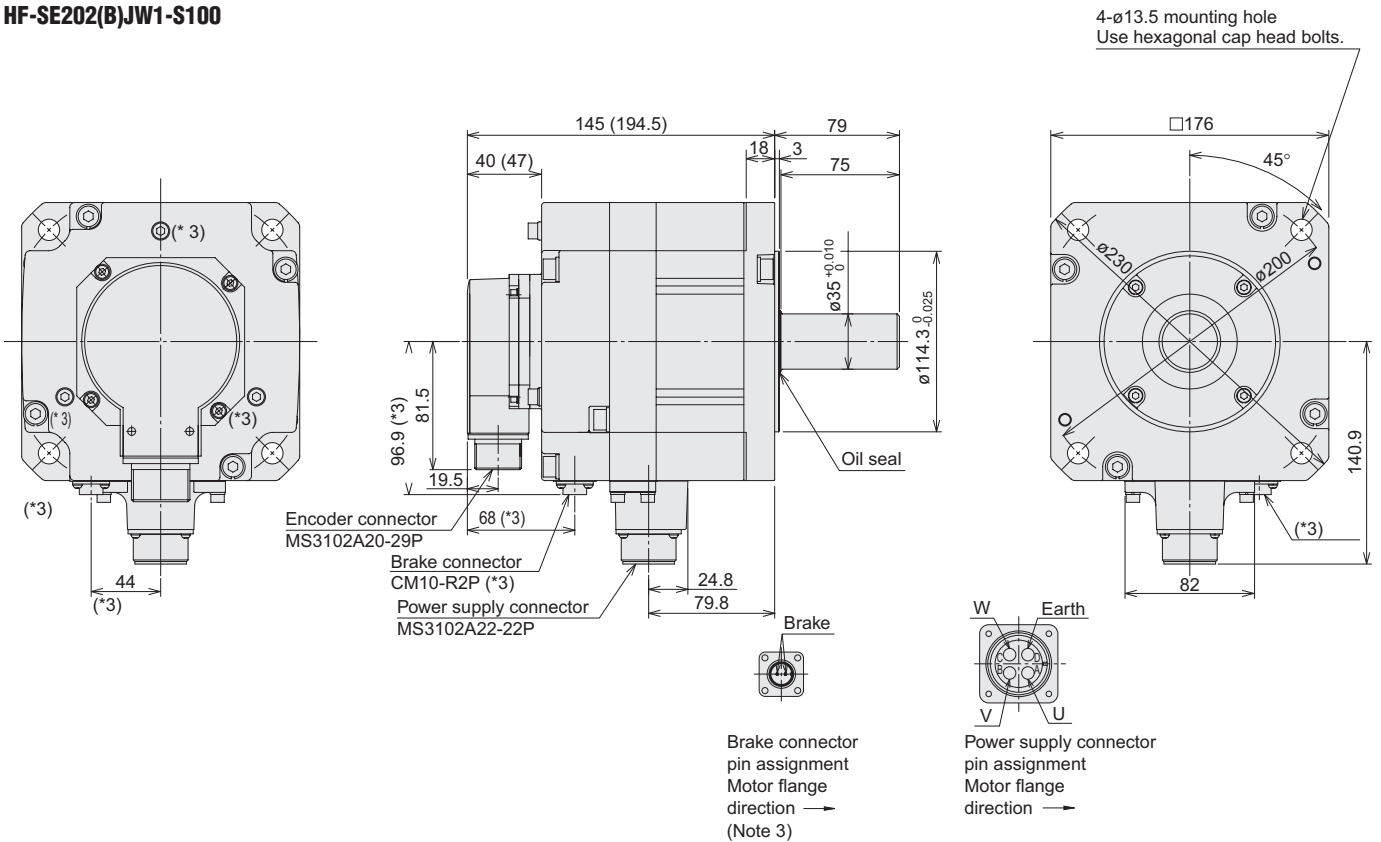

Notes:

1. Use a friction coupling to fasten a load.
2. Dimensions inside () are for the models with an electromagnetic brake.
3. Only for the models with an electromagnetic brake. The electromagnetic brake terminals do not have polarity.
4. For dimensions where there is no tolerance listed, use general tolerance.

MR-J3 Servomotors and Amplifiers

With a capacity range of 50W to 55kW, we reduced the size of both the amplifier and motor, added a high resolution encoder and advanced auto-tuning and vibration control. The J3's high torque motor can operate at up to 6000 rpm, and with a speed frequency response of 2100Hz. Twenty percent smaller than its predecessor, the J3's high resolution 262,144ppr encoder is mounted as standard to provide stability even at low speeds. Mitsubishi Electric Automation's original model adaptive control and ever-evolving automatic tuning function makes precise tuning easy and the J3's advanced vibration control suppresses vibrations automatically. Set-up, diagnostics, and tuning are easy, thanks to MR-Configurator, a Windows™-based software package. MR-Configurator has many improved diagnostic functions, such as an advanced machine analyzer, software oscilloscope, and high speed monitor. A parameter setting window makes start-up easy, and a USB interface enables high-speed sampling and long-term wavelength measurement. The MR-J3 supports the following control methods: Position, Speed, Torque, SSCNET III Network, CC-Link, RS-485 Multi Drop and now Turret Index.

MR-J3-A MR-J3-A-RJ070

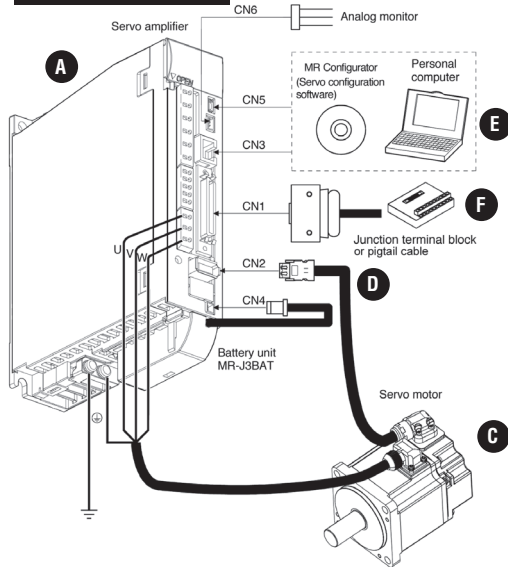

MR-J3-B Safety

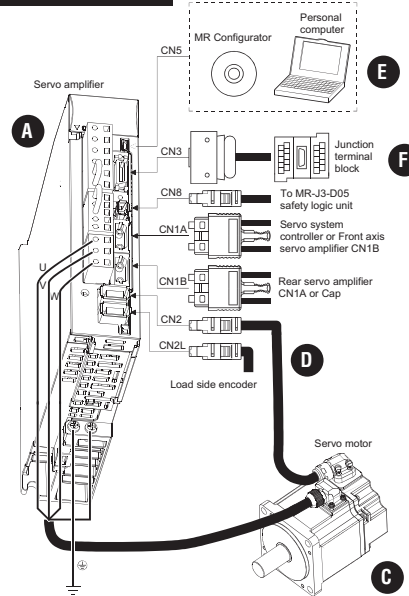

MR-J3-T

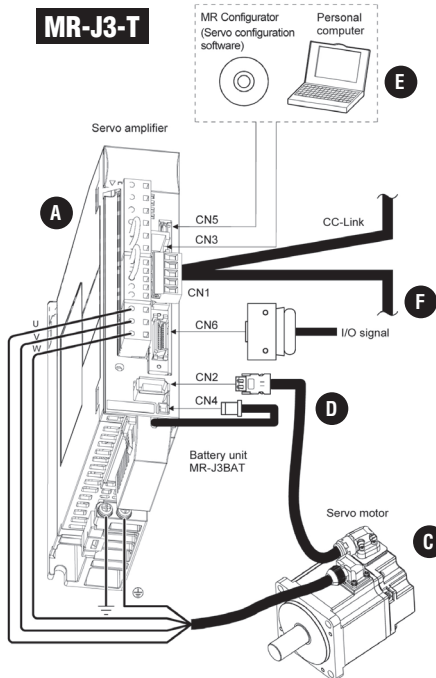



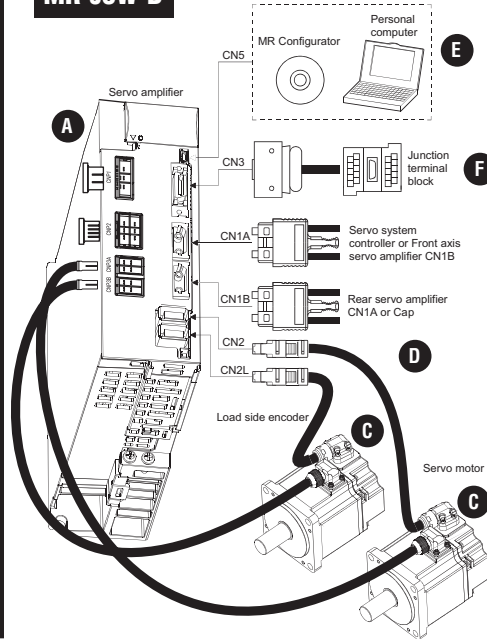

MR-J3W-B



A. Amplifier	254
B. Converter (Required for 30KW ~ 55KW 200/400V amplifiers) (Not shown in above diagrams).....	265
C. Motor	266
D. Cables and Connectors	283
E. Software and Manuals	298
F. Optional Accessories	298

A MR-J3 Amplifiers

Amplifier Types

Type	Interface						Control Mode						Setup Software	Model	Power	Source Capacity (*1)	Compatible Motor Series									
	Pulse Train	Analog	DIO	SSCNET III	RS-422 Multi-Drop	CC-Link	Position	Speed	Torque	Position Functions	Fully Closed Loop Control	Turret Index					HF-KP	HF-MP	HF-SP	HF-JP	HC-LP	HC-RP	HC-UP	HA-LP		
A-Type 	x	x	-	-	x	-	x	x	x	-	-	x	x	MR-J3_A	3-Phase 200VAC	0.05 ~ 37kW	x	x	x	x	x	x	x	x	x	
														MR-J3-_A1	1-Phase 100VAC	0.05 ~ 0.4kW	x	x	-	-	-	-	-	-	-	-
														MR-J3-_A4	3-Phase 400VAC	0.5 ~ 55kW	-	-	x	x	-	-	-	-	-	x
B Safety Type 	-	-	-	x	-	-	x	x	x	-	x	-	x	MR-J3-_BS	3-Phase 200VAC	0.05 ~ 37kW	x	x	x	x	x	x	x	x	x	
														MR-J3-_BS1	1-Phase 100VAC	0.05 ~ 0.4kW	x	x	-	-	-	-	-	-	-	-
														MR-J3-_BS4	3-Phase 400VAC	0.5 ~ 55kW	-	-	x	x	-	-	-	-	-	x
B Dual Axis 	-	-	-	x	-	-	x	x	x	-	-	-	x	MR-J3W-_B	3-Phase 200VAC	0.05 ~ 0.75kW	x	x	-	-	-	-	-	-		
T-Type 	x (*2)	-	x (*3)	-	x	x	x	-	-	x	-	-	x	MR-J3-_T	3-Phase 200VAC	0.05 ~ 25kW	x	x	x	x	x	x	x	x	x	
														MR-J3-_T1	1-Phase 100VAC	0.05 ~ 0.4kW	x	x	-	-	-	-	-	-	-	-
														MR-J3-_T4	3-Phase 400VAC	0.5 ~ 22kW	-	-	x	x	-	-	-	-	-	x

- Notes:
- Capacity selection software MSIZE (MRZJW3-MOTSZ111) can be downloaded for free from www.meau.com.
 - Please use the manual pulse generator (MR-HDP01).
 - Please use the extended IO unit (MR-J3-D01).

100V/200V Amplifier Selection: (Example Part No. = MR-J3-10BS)

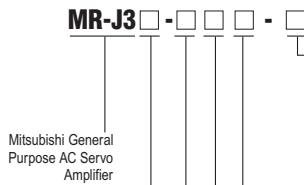

Symbol	Special Types
None	Standard J3 Amplifier
U1_	400% Maximum Torque (*1)
RJ070	Turret Index (*2)

Notes:
 1. JP motors only.
 2. Available on MR-J3-A type only.

Symbol	Power Supply
None	3-phase 200VAC or 1-phase 230VAC (*1)
1	1-phase 100VAC (*2)

Notes:
 1. The 1-phase 200VAC is available on MR-J3-70 or smaller.
 2. The 1-phase 100VAC is available on MR-J3-40 or smaller.

Symbol	Special Types
None	Standard
W	Dual Axis (*1)

Note:
 1. B type only. Available for 200, 400, 750W only.
 Safety option not available.

A: General Purpose Interface
 B: MR-J3W Type Amplifiers Only
 BS: SSCNET III Interface
 T: CC-Link Interface

Symbol	Compatible Motors							
	HF-KP	HF-MP	HF-SP	HF-JP	HC-LP	HC-RP	HC-UP	HA-LP
10	053, 13	053, 13	—	—	—	—	—	—
20	23	23	—	—	—	—	—	—
40	43	43	—	—	—	—	—	—
60	—	—	51, 53	52	52	—	—	—
70	73	73	—	73	—	—	72	—
100	—	—	81, 102	103	53 (*3)	102	—	—
200	—	—	121, 201, 152, 202	153, 203	73, 103 (*3)	152	103, 153	152
350	—	—	301, 352	353	153, 203 (*3)	202	203	202
500	—	—	421, 502	503	353 (*3)	302	353, 503	352, 502
700	—	—	702	—	503 (*3)	—	—	—
11K	—	—	—	11K1M (*6)	—	—	—	601, 701M, 702
15K	—	—	—	15K1M (*6)	—	—	—	15K1, 15K1M, 15K2
22K	—	—	—	—	—	—	—	20K1, 25K1, 22K1M, 22K2
DU30K (*1, *2)	—	—	—	—	—	—	—	30K1, 30K1M, 30K2
DU37K (*1, *2)	—	—	—	—	—	—	—	37K1, 37K1M, 37K2
Dual Axis	22	053, 13, 23	053, 13, 23	—	—	—	—	—
	44	053(*4, *5), 13(*4, *5), 23, 43	053(*4, *5), 13(*4, *5), 23, 43	—	—	—	—	—
	77	43(*4, *5), 73	43(*4, *5), 73	51(*4, *5), 52(*4, *5)	—	—	52 (*2, *3)	72 (*2, *3)

Notes:
 1. Converter Unit MR-J3-CR55K is required for 30kW and 37kW amplifiers.
 2. Available for MR-J3-A and B Safety types only.
 3. Use this servo motor with a dedicated servo amplifier MR-J3- A(4)/BS(4)/T(4)-U1_ when increasing the maximum torque.
 4. These motors can be used by setting parameter No. Po04 to “_1_”.
 5. These motors are not compatible with FX3U-20SSC-H controller.
 6. Use a dedicated servo amplifier MR-J3-A(4)/BS(4)/T(4)-LR-/LW for HF-JP11K1M(4) and HF-JP15K1M(4). These servo motors cannot be used with any other servo amplifiers without “-LR”.

400V Amplifier Selection: (Example Part No. = MR-J3-60A4)

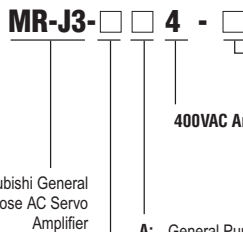

Symbol	Power Supply
None	Standard J3 Amplifier
U1_	400% Maximum Torque (*2)
RJ070	Turret Index (*1)

Notes:
 1. Available on MR-J3-A type only.
 2. JP motors only.

A: General Purpose Interface
 BS: SSCNET III Interface
 T: CC-Link Interface (up to 22kW only)

Symbol	Compatible Motors		
	HF-SP	HF-JP	HA-LP
60	524	534	—
100	1024	734, 1034	534 (*3)
200	1524, 2024	1534, 2034	734, 1034 (*3)
350	3524	3534	1534, 2034 (*3)
500	5024	5034	3534 (*3)
700	7024	—	5034 (*3)
11K	—	11K1M4 (*4)	—
15K	—	15K1M4 (*4)	—
22K	—	—	—
DU30K (*1, *2)	—	—	—
DU37K (*1, *2)	—	—	—
DU45K (*1, *2)	—	—	—
DU55K (*1, *2)	—	—	—

Notes:
 1. Converter Unit MR-J3-CR55K4 is required for 30kW to 55kW amplifiers.
 2. Available for the MR-J3-A and B Safety types only.
 3. These motors can be used by setting parameter No. Po04 to “_1_”.
 4. Use a dedicated servo amplifier MR-J3-A(4)/BS(4)/T(4)-LR-/LW for HF-JP11K1M(4) and HF-JP15K1M(4). These servo motors cannot be used with any other servo amplifiers without “-LR”.

MR-J3-A Servo Amplifier Specifications 100/200V 22kW or Smaller

Servo Amplifier Model MR-J3-		10A	20A	40A	60A	70A	100A	200A	350A	500A	700A	11KA	15KA	22KA	10A1	20A1	40A1	
Stock Item		S	S	S	S	S	S	S	S	S	S	S	S	S	S	S	S	
Main Circuit Power Supply	Voltage/Frequency (*1, *2)	3-phase 200 to 230VAC 50/60Hz or 1-phase 200 to 230VAC 50/60Hz (*10)					3-phase 200 to 230VAC 50/60Hz						1-phase 100 to 120VAC 50/60Hz					
	Permissible Voltage Fluctuation	For 3-phase 200 to 230VAC: 3-phase 170 to 253VAC For 1-phase 200 to 230VAC: 1-phase 170 to 253VAC					3-phase 170 to 253VAC						1-phase 85 to 132VAC					
	Permissible Frequency Fluctuation	±5% maximum																
Control Circuit Power Supply	Voltage/Frequency	1-phase 200 to 230VAC 50/60Hz (*10)					1-phase 200 to 230VAC 50/60Hz						1-phase 100 to 120VAC 50/60Hz					
	Permissible Voltage Fluctuation	1-phase 170 to 253VAC																
	Permissible Frequency Fluctuation	±5% maximum																
	Power Consumption (W)	30					45						30					
Interface Power Supply		24VDC ±10% (required current capacity: 300mA (*7))																
Regenerative Resistor/Tolerable Regenerative Power (W) (*3, *4)	Built-in Regenerative Resistor	-	10	10	10	20	20	100	100	130	170	-	-	-	-	10	10	
	External Regenerative Resistor (Standard Accessory) (*5, *6)	-	-	-	-	-	-	-	-	-	-	500 (800)	850 (1300)	850 (1300)	-	-	-	
Control System		Sine-wave PWM control/current control system																
Dynamic Brake		Built-in (*8, *13)										External option			Built-in (*8, *13)			
Safety Features		Overcurrent shutdown, regeneration overvoltage shutdown, overload shutdown (electronic thermal), servo motor overheat protection, encoder fault protection, regeneration fault protection, undervoltage/sudden power outage protection, overspeed protection, excess error protection																
Position Control Mode	Maximum Input Pulse Frequency	1Mpps (when using differential receiver), 200kpps (when using open collector), (4Mpps (*11))																
	Positioning Feedback Pulse	Resolution per encoder/servo motor rotation: 262144 p/rev																
	Command Pulse Multiple	Electronic gear A/B multiple, A: 1 to 1048576, B: 1 to 1048576, 1/10 < A/B < 2000																
	Positioning Complete Width Setting	0 to ±10000 pulses (command pulse unit)																
	Excess Error	±3 rotations																
	Torque Limit	Set by parameters or external analog input (0 to +10VDC/maximum torque)																
Speed Control Mode	Speed Control Range	Analog speed command 1:2000, internal speed command 1:5000																
	Analog Speed Command Input	0 to ±10VDC/rated speed (possible to change the speed in 10V using the parameter No. PC12.) (*12)																
	Speed Fluctuation Rate	±0.01% maximum (load fluctuation 0 to 100%) 0% (power fluctuation ±10%) ±0.2% maximum (ambient temperature 25°C±10°C (59°F to 95°F)), when using analog speed command																
	Torque Limit	Set by parameters or external analog input (0 to +10VDC/maximum torque) (*12)																
Torque Control Mode	Analog Torque Command Input	0 to ±8VDC/maximum torque (input impedance 10 to 12kΩ) (*12)																
	Speed Limit	Set by parameters or external analog input (0 to ±10VDC/rated speed)																
Structure		Self-cooling open (IP00)					Fan cooling open (IP00)						Self-cooling open (IP00)					
Environment	Ambient Temperature (*6, *9)	0 to 55°C (32 to 131°F) (non-freezing), storage: -20 to 65°C (-4 to 149°F) (non-freezing)																
	Ambient Humidity	90% RH maximum (non-condensing), storage: 90% RH maximum (non-condensing)																
	Atmosphere	Indoors (no direct sunlight); no corrosive gas, inflammable gas, oil mist or dust																
	Elevation	1000m or less above sea level																
	Vibration	5.9m/s ² maximum																
Mass kg (lb)		0.8 (1.8)	0.8 (1.8)	1.0 (2.2)	1.0 (2.2)	1.4 (3.1)	1.4 (3.1)	2.1 (4.6)	2.3 (5.1)	4.6 (10)	6.2 (14)	18 (40)	18 (40)	19 (42)	0.8 (1.8)	0.8 (1.8)	1.0 (2.2)	

Notes:

- Rated output and speed of a servo motor are applicable when the servo amplifier, combined with the servo motor, is operated within the specified power supply voltage and frequency. Torque drops when the power supply voltage is below the specified value.
- For torque characteristics when combined with a servo motor, refer to the section "Servo motor torque characteristics" in this catalog.
- Optimal regenerative resistor varies for each system. Select the most suitable regenerative resistor by using the capacity selection software.
- Refer to the section "Options • Optional regeneration unit" in this catalog for the tolerable regenerative power (W).
- The servo amplifier (MR-J3-*KA-PX*) without an enclosed regenerative resistor is also available.
- The value in () applies when the external regenerative resistors, GRZG400-*Ω*, (standard accessory) are used with cooling fans (2 units of 92 x 92mm, minimum air flow: 1.0m³/min). Note that change in the parameter No. PA02 is required.
- 300mA is the value when all of the input/output points are used. The current capacity can be stepped down according to the number of input/output points in use. Refer to "MR-J3-*A* SERVO AMPLIFIER INSTRUCTION MANUAL" for details.
- Special specification models without a dynamic brake, MR-J3-*A*-ED and MR-J3-*A1*-ED, are also available for 7kW or smaller servo amplifier.
- The MR-J3-350A or smaller servo amplifier can be installed close together. In this case, keep the ambient temperature within 0 to 45°C (32 to 113°F), or use the servo amplifier with 75% or less of the effective load rate.
- The special specification model, MR-J3-*A*-U004, is also available for 1-phase 200 to 240 VAC.
- 4Mpps compatible servo amplifier (MR-J3-*A*(1)-KE) is also available.
- High resolution analog speed command and analog torque command is available with a set of MR-J3-*A*(1)-RJ040 and the extension IO unit, MR-J3-D01.
- When using the built-in dynamic brake, refer to "MR-J3-*A* SERVO AMPLIFIER INSTRUCTION MANUAL" for the permissible load inertia moment ratio.

MR-J3-A Servo Amplifier Specifications: 200VAC, 30kW or Larger

Drive Unit Model		MR-J3-DU30KA	MR-J3-DU37KA
Stock Item		-	-
Main Circuit Power Supply	Voltage/Frequency (*1)	The drive unit's main circuit power is supplied from the converter unit.	
	Permissible Voltage Fluctuation		
	Permissible Frequency Fluctuation		
Control Circuit Power Supply	Voltage/Frequency	1-phase 200 to 230VAC 50/60Hz	
	Permissible Voltage Fluctuation	1-phase 170 to 253VAC	
	Permissible Frequency Fluctuation	±5% maximum	
	Power Consumption (W)	45	
Interface Power Supply		24VDC ±10% (required current capacity: 300mA (*3))	
Control System		Sine-wave PWM control/current control system	
Dynamic Brake		External option	
Safety Features		Overcurrent shutdown, overload shutdown (electronic thermal), servo motor overheat protection, encoder fault protection, undervoltage/sudden power outage protection, overspeed protection, excess error protection	
Position Control Mode	Maximum Input Pulse Frequency	1Mpps (when using differential receiver), 200kpps (when using open collector)	
	Positioning Feedback Pulse	Resolution per encoder/servo motor rotation: 262144 p/rev	
	Command Pulse Multiple	Electronic gear A/B multiple, A: 1 to 1048576, B: 1 to 1048576, 1/10 < A/B < 2000	
	Positioning Complete Width Setting	0 to ±10000 pulses (command pulse unit)	
	Excess Error	±3 rotations	
	Torque Limit	Set by parameters or external analog input (0 to +10VDC/maximum torque)	
Speed Control Mode	Speed Control Range	Analog speed command 1:2000, internal speed command 1:5000	
	Analog Speed Command Input	0 to ±10VDC/rated speed (possible to change the speed in 10V using the parameter No. PC12.)	
	Speed Fluctuation Rate	±0.01% maximum (load fluctuation 0 to 100%) 0% (power fluctuation ±10%) ±0.2% maximum (ambient temperature 25°C±10°C (59°F to 95°F)), when using analog speed command	
	Torque Limit	Set by parameters or external analog input (0 to +10VDC/maximum torque)	
Torque Control Mode (*2)	Analog Torque Command Input	0 to ±8VDC/maximum torque (input impedance 10 to 12kΩ)	
	Speed Limit	Set by parameters or external analog input (0 to ±10VDC/rated speed)	
Structure		Fan cooling open (IP00)	
Mass kg (lb)		26 (57)	
Environment	Ambient Temperature	0 to 55°C (32 to 131°F) (non-freezing), storage: -20 to 65°C (-4 to 149°F) (non-freezing)	
	Ambient Humidity	90% RH maximum (non-condensing), storage: 90% RH maximum (non-condensing)	
	Atmosphere	Indoors (no direct sunlight); no corrosive gas, inflammable gas, oil mist or dust	
	Elevation	1000m or less above sea level	
	Vibration	5.9m/s ² maximum	

Notes:

- Rated output and speed of a servo motor are applicable when the drive unit and the converter unit, combined with the servo motor, are operated within the specified power supply voltage and frequency. Torque drops when the power supply voltage is below the specified value.
- For torque characteristics when combined with a servo motor, refer to the section "Servo motor torque characteristics" in this catalog.
- The interface power supply can be shared with the drive unit and the converter unit. When all of the input/output points are used, 300mA is required for the drive unit, and 130mA is required for the converter unit. The current capacity can be stepped down according to the number of input/output points in use. Refer to "MR-J3- A SERVO AMPLIFIER INSTRUCTION MANUAL" for details.

MR-J3-A Servo Amplifier Specifications, 400VAC, 22kW or Smaller

Servo Amplifier Model MR-J3-		60A4	100A4	200A4	350A4	500A4	700A4	11KA4	15KA4	22KA4
Stock Item		S	S	S	S	S	S	S	S	S
Main Circuit Power Supply	Voltage/Frequency (*1, *2)	3-phase 380 to 480VAC 50/60Hz								
	Permissible Voltage Fluctuation	3-phase 323 to 528VAC								
	Permissible Frequency Fluctuation	±5% maximum								
Control Circuit Power Supply	Voltage/Frequency	1-phase 380 to 480VAC 50/60Hz								
	Permissible Voltage Fluctuation	1-phase 323 to 528VAC								
	Permissible Frequency Fluctuation	±5% maximum								
	Power Consumption (W)	30				45				
Interface Power Supply		24VDC ±10% (required current capacity: 300mA (*7))								
Regenerative Resistor/Tolerable Regenerative Power (W) (*3, *4)	Built-in Regenerative Resistor	15	15	100	100	130 (*9)	170 (*9)	-	-	-
	External Regenerative Resistor (Standard Accessory) (*5, *6)	-	-	-	-	-	-	500 (800)	850 (1300)	850 (1300)
Control System		Sine-wave PWM control/current control system								
Dynamic Brake		Built-in (*8, *10)						External option		
Safety Features		Overcurrent shutdown, regeneration overvoltage shutdown, overload shutdown (electronic thermal), servo motor over-heat protection, encoder fault protection, regeneration fault protection, undervoltage/sudden power outage protection, overspeed protection, excess error protection								
Position Control Mode	Maximum Input Pulse Frequency	1Mpps (when using differential receiver), 200kpps (when using open collector)								
	Positioning Feedback Pulse	Resolution per encoder/servo motor rotation: 262144 p/rev								
	Command Pulse Multiple	Electronic gear A/B multiple, A: 1 to 1048576, B: 1 to 1048576, 1/10 < A/B < 2000								
	Positioning Complete Width Setting	0 to ±10000 pulses (command pulse unit)								
	Excess Error	±3 rotations								
Torque Limit		Set by parameters or external analog input (0 to +10VDC/maximum torque)								
Speed Control Mode	Speed Control Range	Analog speed command 1:2000, internal speed command 1:5000								
	Analog Speed Command Input	0 to ±10VDC/rated speed (possible to change the speed in 10V using the parameter No. PC12.) (*11)								
	Speed Fluctuation Rate	±0.01% maximum (load fluctuation 0 to 100%) 0% (power fluctuation ±10%) ±0.2% maximum (ambient temperature 25°C±10°C (59°F to 95°F)), when using analog speed command								
	Torque Limit	Set by parameters or external analog input (0 to +10VDC/maximum torque) (*11)								
Torque Control Mode	Analog Torque Command Input	0 to ±8VDC/maximum torque (input impedance 10 to 12kΩ) (*11)								
	Speed Limit	Set by parameters or external analog input (0 to ±10VDC/rated speed)								
Structure		Self-cooling open (IP00)			Fan cooling open (IP00)					
Environment	Ambient Temperature (*6)	0 to 55°C (32 to 131°F) (non-freezing), storage: -20 to 65°C (-4 to 149°F) (non-freezing)								
	Ambient Humidity	90% RH maximum (non-condensing), storage: 90% RH maximum (non-condensing)								
	Atmosphere	Indoors (no direct sunlight); no corrosive gas, inflammable gas, oil mist or dust								
	Elevation	1000m or less above sea level								
	Vibration	5.9m/s ² maximum								
Mass kg (lb)		1.7 (3.7)	1.7 (3.7)	2.1 (4.6)	4.6 (10)	4.6 (10)	6.2 (14)	18 (40)	18 (40)	19 (42)

Notes:

- Rated output and speed of a servo motor are applicable when the servo amplifier, combined with the servo motor, is operated within the specified power supply voltage and frequency. Torque drops when the power supply voltage is below the specified value.
- For torque characteristics when combined with a servo motor, refer to the section "Servo motor torque characteristics" in this catalog.
- Optimal regenerative resistor varies for each system. Select the most suitable regenerative resistor by using the capacity selection software.
- Refer to the section "Options • Optional regeneration unit" in this catalog for the tolerable regenerative power (W).
- The servo amplifier (MR-J3- KA4-PX) without an enclosed regenerative resistor is also available.
- The value in () applies when the external regenerative resistors, GRZG400-Ω, (standard accessory) are used with cooling fans (2 units of 92 x 92mm, minimum air flow: 1.0m³/min). Note that change in the parameter No. PA02 is required.
- 300mA is the value when all of the input/output points are used. The current capacity can be stepped down according to the number of input/output points in use. Refer to "MR-J3- A SERVO AMPLIFIER INSTRUCTION MANUAL" for details.
- Special specification models without a dynamic brake, MR-J3- A4 -ED, are also available for 7kW or smaller servo amplifier.
- The amplifier built-in resistor is compatible with the maximum torque deceleration when the motor is used within the rated speed and the recommended load/motor inertia moment ratio. Contact Mitsubishi if the operating motor speed and the load/motor inertia moment ratio exceed the rated speed and the recommended ratio.
- When using the built-in dynamic brake, refer to "MR-J3- A SERVO AMPLIFIER INSTRUCTION MANUAL" for the permissible load inertia moment ratio.
- For the servo amplifier 11kW to 22kW, high resolution analog speed command and analog torque command is available with a set of MR-J3- A4-RJ040 and the extension IO unit, MR-J3-D01. Servo amplifier 7kW or smaller, compatible with high resolution analog speed torque command, will be available.

MR-J3-A Servo Amplifier Specifications, 400VAC, 30kW or Larger

Drive Unit Model		MR-J3-DU30KA4	MR-J3-DU37KA4	MR-J3-DU45KA4	MR-J3-55KA4
Stock Item					
Main Circuit Power Supply	Voltage/Frequency (*1)	The drive unit's main circuit power is supplied from the converter unit.			
	Permissible Voltage Fluctuation				
	Permissible Frequency Fluctuation				
Control Circuit Power Supply	Voltage/Frequency	1-phase 380 to 480VAC 50/60Hz			
	Permissible Voltage Fluctuation	1-phase 323 to 528VAC			
	Permissible Frequency Fluctuation	±5% maximum			
	Power Consumption (W)	45			
Interface Power Supply		24VDC ±10% (required current capacity: 300mA (*3))			
Control System		Sine-wave PWM control/current control system			
Dynamic Brake		External option			
Safety Features		Overcurrent shutdown, overload shutdown (electronic thermal), servo motor overheat protection, encoder fault protection, undervoltage/sudden power outage protection, overspeed protection, excess error protection			
Position Control Mode	Maximum Input Pulse Frequency	1Mpps (when using differential receiver), 200kpps (when using open collector)			
	Positioning Feedback Pulse	Resolution per encoder/servo motor rotation: 262144 p/rev			
	Command Pulse Multiple	Electronic gear A/B multiple, A: 1 to 1048576, B: 1 to 1048576, 1/10 < A/B < 2000			
	Positioning Complete Width Setting	0 to ±10000 pulses (command pulse unit)			
	Excess Error	±3 rotations			
	Torque Limit	Set by parameters or external analog input (0 to +10VDC/maximum torque)			
Speed Control Mode	Speed Control Range	Analog speed command 1:2000, internal speed command 1:5000			
	Analog Speed Command Input	0 to ±10VDC/rated speed (possible to change the speed in 10V using the parameter No. PC12.)			
	Speed Fluctuation Rate	±0.01% maximum (load fluctuation 0 to 100%) 0% (power fluctuation ±10%) ±0.2% maximum (ambient temperature 25°C±10°C (59°F to 95°F)), when using analog speed command			
	Torque Limit	Set by parameters or external analog input (0 to +10VDC/maximum torque)			
Torque Control Mode (*2)	Analog Torque Command Input	0 to ±8VDC/maximum torque (input impedance 10 to 12kΩ)			
	Speed Limit	Set by parameters or external analog input (0 to ±10VDC/rated speed)			
Structure		Fan cooling open (IP00)			
Mass kg (lb)		18 (40)		26 (57)	
Environment	Ambient Temperature	0 to 55°C (32 to 131°F) (non-freezing), storage: -20 to 65°C (-4 to 149°F) (non-freezing)			
	Ambient Humidity	90% RH maximum (non-condensing), storage: 90% RH maximum (non-condensing)			
	Atmosphere	Indoors (no direct sunlight); no corrosive gas, inflammable gas, oil mist or dust			
	Elevation	1000m or less above sea level			
	Vibration	5.9m/s ² maximum			

Notes:

- Rated output and speed of a servo motor are applicable when the drive unit and the converter unit, combined with the servo motor, are operated within the specified power supply voltage and frequency. Torque drops when the power supply voltage is below the specified value.
- For torque characteristics when combined with a servo motor, refer to the section "Servo motor torque characteristics" in this catalog.
- The interface power supply can be shared with the drive unit and the converter unit. When all of the input/output points are used, 300mA is required for the drive unit, and 130mA is required for the converter unit. The current capacity can be stepped down according to the number of input/output points in use. Refer to "MR-J3-A SERVO AMPLIFIER INSTRUCTION MANUAL" for details.

MR-J3-A-RJ070 Servo Amplifier Specifications 200VAC, 22kW or Smaller

Servo Amplifier Model MR-J3-_-RJ070		10A	20A	40A	60A	70A	100A	200A	350A	500A	700A	11KA	15KA	22KA	10A1	20A1	40A1	
Stock Item		S	S	S	S	S	-	S	S	S	S	-	-	-	-	-	-	
Main Circuit Power Supply	Voltage/Frequency	3-phase 200 to 230VAC 50/60Hz or 1-phase 200 to 230VAC 50/60Hz					3-phase 200 to 230VAC 50/60Hz					1-phase 100 to 120VAC 50/60Hz						
	Permissible Voltage Fluctuation	For 1-phase 230VAC: 207 to 253VAC For 3-phase 200 to 230VAC: 170 to 253VAC					1-phase 170 to 253VAC					1-phase 85 to 132VAC						
	Permissible Frequency Fluctuation	±5% maximum																
Control Circuit Power Supply	Voltage/Frequency	1-phase 200 to 230VAC 50/60Hz										1-phase 100 to 120VAC 50/60Hz						
	Permissible Voltage Fluctuation	1-phase 170 to 253VAC										1-phase 85 to 132VAC						
	Permissible Frequency Fluctuation	±5% maximum																
	Power Consumption (W)	30					45					30						
Inrush Current		Refer to MR-J3-_A Servo Amplifier Instruction Manual																
Interface Power Supply		24VDC ±10% (300mA) (*1)																
Control System		Sine-wave PWM control/current control system																
Dynamic Brake		Built-in					External option					Built-in						
Safety Features		Overcurrent shutdown, regeneration overvoltage shutdown, overload shutdown (electronic thermal), servo motor overheat protection, encoder fault protection, regeneration fault protection, undervoltage/sudden power outage protection, overspeed protection, excess error protection																
Indexer Positioning (Turret)	Max. No. of Stations	MR-J3-_A-RJ070 only: 15 stations, With MR-J3-D01: 255 stations																
	Number of Gears on Servomotor / Machine (Electronic Gears)	1/9999<MCX/CDV<9999, CDVx STN<32767, CMX x CDV<100000																
	In-Position Range Setting	0 to ±10000 pulses (command pulse unit)																
	Error Excessive	±3 rotations																
	Torque Limit	Set by parameters or external analog input (0 to +10VDC/maximum torque)																
Structure		Self-cooling open (IP00)					Forced-cooling open (IP00)					Self-cooling open (IP00)						
Environment	Ambient Temperature	0 to 55°C (32 to 131°F) (non-freezing), storage: -20 to 65°C (-4 to 149°F) (non-freezing) (*2)																
	Ambient Humidity	90% RH maximum (non-condensing), storage: 90% RH maximum (non-condensing)																
	Atmosphere	Indoors (no direct sunlight); no corrosive gas, inflammable gas, oil mist or dust																
	Elevation	1000m or less above sea level																
	Vibration	5.9m/s ² maximum																
Mass kg (lb)		0.8 (1.8)	0.8 (1.8)	1.0 (2.2)	1.0 (2.2)	1.4 (3.1)	1.4 (3.1)	2.1 (4.6)	2.3 (5.1)	4.6 (10)	6.2 (14)	18 (40)	18 (40)	19 (42)	0.8 (1.8)	0.8 (1.8)	1.0 (2.2)	

Notes:

- 300mA is the value when all I/O signals are used. The current capacity can be decreased by reducing the number of I/O points.
- When closely mounting the servo amplifiers of 3.5kW or less, operate them at the ambient temperatures of 0 to 45°C or at 75% or smaller effective ratio loads.

MR-J3-A-RJ070 Servo Amplifier Specifications 400VAC, 22kW or Smaller

Servo Amplifier Model MR-J3-_-RJ070		60A4	100A4	200A4	350A4	500A4	700A4	11KA4	15KA4	22KA4
Stock Item		-								
Main Circuit Power Supply	Voltage/Frequency	3-phase 380 to 480VAC 50/60Hz								
	Permissible Voltage Fluctuation	3-phase 323 to 528VAC								
	Permissible Frequency Fluctuation	±5% maximum								
	Power Supply Equipment Capacity	Refer to MR-J3-_A Servo Amplifier Instruction Manual								
	Inrush Current	Refer to MR-J3-_A Servo Amplifier Instruction Manual								
Control Circuit Power Supply	Voltage/Frequency	1-phase 380 to 480VAC 50/60Hz								
	Permissible Voltage Fluctuation	1-phase 323 to 528VAC								
	Permissible Frequency Fluctuation	±5% maximum								
	Power Consumption (W)	30			45					
Inrush Current		Refer to MR-J3-_A Servo Amplifier Instruction Manual								
Interface Power Supply		24VDC ±10% (300mA) (*1)								
Control System		Sine-wave PWM control/current control system								
Dynamic Brake		Built-in			External option					
Safety Features		Overcurrent shutdown, regeneration overvoltage shutdown, overload shutdown (electronic thermal), servo motor overheat protection, encoder fault protection, regeneration fault protection, undervoltage/sudden power outage protection, overspeed protection, excess error protection								
Indexer Positioning (Turret)	Maximum Number of Stations	MR-J3-_A-RJ070 only: 15 stations, With MR-J3-D01: 255 stations								
	Number of Gears on Servomotor / Machine (Electronic Gears)	1/9999<MCX/CDV<9999, CDV x STN<32767, CMX x CDV<100000								
	In-Position Range Setting	0 to ±10000 pulses (command pulse unit)								
	Error Excessive	±3 rotations								
	Torque Limit	Set by parameters or external analog input (0 to +10VDC/maximum torque)								
Structure		Self-cooling open (IP00)			Forced cooling open (IP00)					
Environment	Ambient Temperature	0 to 55°C (32 to 131°F) (non-freezing), storage: -20 to 65°C (-4 to 149°F) (non-freezing)								
	Ambient Humidity	90% RH maximum (non-condensing), storage: 90% RH maximum (non-condensing)								
	Atmosphere	Indoors (no direct sunlight); no corrosive gas, inflammable gas, oil mist or dust								
	Elevation	1000m or less above sea level								
	Vibration	5.9m/s ² maximum								
Mass kg (lb)		1.7 (3.7)	1.7 (3.7)	2.1 (4.6)	4.6 (10)	4.6 (10)	6.2 (14)	18 (40)	18 (40)	19 (42)

Note: 1. 300mA is the value when all I/O signals are used. The current capacity can be decreased by reducing the number of I/O points.

MR-J3-B Safety Servo Amplifier Specifications 100V/200VAC, 22kW or Smaller

Servo Amplifier Model MR-J3-		10BS	20BS	40BS	60BS	70BS	100BS	200BS	350BS	500BS	700BS	11KBS	15KBS	22KBS	10BS1	20BS1	40BS1	
Stock Item		S	S	S	S	S	S	S	S	S	S	S	S	S	S	S	S	
Main Circuit Power Supply	Voltage/Frequency (*1, *2)	3-phase 200 to 230VAC 50/60Hz or 1-phase 200 to 230VAC 50/60Hz (*10)					3-phase 200 to 230VAC 50/60Hz							1-phase 100 to 120VAC 50/60Hz				
	Permissible Voltage Fluctuation	For 3-phase 200 to 230VAC: 3-phase 170 to 253VAC For 1-phase 200 to 230VAC: 1-phase 170 to 253VAC					3-phase 170 to 253VAC							1-phase 85 to 132VAC				
	Permissible Frequency Fluctuation	±5% maximum																
Control Circuit Power Supply	Voltage/Frequency	1-phase 200 to 230VAC 50/60Hz (*10)					1-phase 200 to 230VAC 50/60Hz							1-phase 100 to 120VAC 50/60Hz				
	Permissible Voltage Fluctuation						1-phase 170 to 253VAC							1-phase 85 to 132VAC				
	Permissible Frequency Fluctuation	±5% maximum																
	Power Consumption (W)	30					45							30				
Interface Power Supply		24VDC ±10% (required current capacity: 150mA (*7))																
Regenerative Resistor/Tolerable Regenerative Power (W) (*3, *4)	Built-in Regenerative Resistor	-	10	10	10	20	20	100	100	130	170	-	-	-	-	10	10	
	External Regenerative Resistor (Standard Accessory) (*5, *6)	-	-	-	-	-	-	-	-	-	-	500 (800)	850 (1300)	850 (1300)	-	-	-	
Control System		Sine-wave PWM Control/Current Control System																
Dynamic Brake		Built-in (*8, *11)										External option			Built-in (*8, *11)			
Safety Features		Overcurrent shutdown, regeneration overvoltage shutdown, overload shutdown (electronic thermal), servo motor overheat protection, encoder fault protection, regeneration fault protection, undervoltage/sudden power outage protection, overspeed protection, excess error protection																
Structure	Self-Cooling Open	Self-cooling open (IP00)					Fan cooling open (IP00)							Self-cooling open (IP00)				
Environment	Ambient Temp. (*9)	0 to 55°C (32 to 131°F) (non-freezing), storage: -20 to 65°C (-4 to 149°F) (non-freezing)																
	Ambient Humidity	90% RH maximum (non-condensing), storage: 90% RH maximum (non-condensing)																
	Atmosphere	Indoors (no direct sunlight); no corrosive gas, inflammable gas, oil mist or dust																
	Elevation	1000m or less above sea level																
	Vibration	5.9m/s ² maximum																
Mass kg (lb)		0.8 (1.8)	0.8 (1.8)	1.0 (2.2)	1.0 (2.2)	1.4 (3.1)	1.4 (3.1)	2.1 (4.6)	2.3 (5.1)	4.6 (10)	6.2 (14)	18 (40)	18 (40)	19 (42)	0.8 (1.8)	0.8 (1.8)	1.0 (2.2)	

Notes:

- Rated output and rated speed of the servo motor used in combination with the servo amplifier are as indicated when using the power supply voltage and frequency listed. The torque drops when the power supply voltage is less than specified.
- For torque characteristics when combined with a servo motor, refer to the section "Servo motor torque characteristics" in the MR-J3 manual.
- Optimal regenerative resistor varies for each system. Select the most suitable regenerative resistor by using the capacity selection software.
- Refer to the section "Options • Optional regeneration unit" in the MR-J3 manual for the tolerable regenerative power (W).
- The servo amplifier (MR-J3-_{KB-PX}) without an enclosed regenerative resistor is also available.
- The value in () applies when the external regenerative resistors, GRZG400-_Ω, (standard accessory) are used with cooling fans (2 units of 92 x 92mm, minimum air flow: 1.0m³/min). Note that change in the parameter No. PA02 is required.
- 150mA is the value when all of the input/output points are used. The current capacity can be stepped down according to the number of input/output points in use. Refer to "MR-J3-_B Safety SERVO AMPLIFIER INSTRUCTION MANUAL" for details.
- Special specification models without a dynamic brake, MR-J3-_{BS-ED} and MR-J3-_{B1-ED}, are also available.
- The MR-J3-350BS or smaller servo amplifier can be installed closely. In this case, keep the ambient temperature within 0 to 45°C (32 to 113°F), or use the servo amplifier with 75% or less of the effective load rate.
- The special specification model, MR-J3-_{BS-U004}, is also available for 1-phase 200 to 240VAC.
- When using the built-in dynamic brake, refer to MR-J3-_B Safety SERVO AMPLIFIER INSTRUCTION MANUAL for the permissible load inertia moment ratio.

MR-J3-B Safety Servo Amplifier Specifications: 200VAC, 30kW or Larger

Drive Unit Model		MR-J3-DU30KBS							MR-J3-DU37KBS						
Stock Item		-													
Main Circuit Power Supply	Voltage/Frequency (*1)	The drive unit's main circuit power is supplied from the converter unit													
	Permissible Voltage Fluctuation														
	Permissible Frequency Fluctuation														
Control Circuit Power Supply	Voltage/Frequency	1-phase 200 to 230VAC 50/60Hz													
	Permissible Voltage Fluctuation	1-phase 170 to 253VAC													
	Permissible Frequency Fluctuation	±5% maximum													
	Power Consumption (W)	45													
Interface Power Supply		24VDC ±10% (required current capacity: 150mA (*2))													
Control System		Sine-wave PWM control/current control system													
Dynamic Brake		External option													
Safety Features		Overcurrent shutdown, overload shutdown (electronic thermal), servo motor overheat protection, encoder fault protection, undervoltage/sudden power outage protection, overspeed protection, excess error protection													
Structure		Fan cooling open (IP00)													
Mass kg (lb)		26 (57)													
Environment	Ambient Temperature	0 to 55°C (32 to 131°F) (non-freezing), storage: -20 to 65°C (-4 to 149°F) (non-freezing)													
	Ambient Humidity	90% RH maximum (non-condensing), storage: 90% RH maximum (non-condensing)													
	Atmosphere	Indoors (no direct sunlight); no corrosive gas, inflammable gas, oil mist or dust													
	Elevation	1000m or less above sea level													
	Vibration	5.9m/s ² maximum													

Notes:

- Rated output and rated speed of the servo motor used in combination with the drive unit and the converter unit are as indicated when using the power supply voltage and frequency listed. The torque drops when the power supply voltage is less than specified.
- The interface power supply can be shared with the drive unit and the converter unit. When all of the input/output points are used, 150mA is required for the drive unit, and 130mA is required for the converter unit. The current capacity can be stepped down according to the number of input/output points in use. Refer to "MR-J3-_B Safety SERVO AMPLIFIER INSTRUCTION MANUAL" for details.

MR-J3-B Safety Servo Amplifier Specifications: 400VAC, 22kW or Smaller

Servo Amplifier Model MR-J3-		60BS4	100BS4	200BS4	350BS4	500BS4	700BS4	11KBS4	15KBS4	22KBS4	
Stock Item		S	S	S	S	S	S	S	S	S	
Main Circuit Power Supply	Voltage/Frequency (*1, *2)	3-phase 380 to 480VAC 50/60Hz									
	Permissible Voltage Fluctuation	3-phase 323 to 528VAC									
	Permissible Frequency Fluctuation	±5% maximum									
Control Circuit Power Supply	Voltage/Frequency	1-phase 380 to 480VAC 50/60Hz									
	Permissible Voltage Fluctuation	1-phase 323 to 528VAC									
	Permissible Frequency Fluctuation	±5% maximum									
	Power Consumption (W)	30				45					
Interface Power Supply		24VDC ±10% (required current capacity: 150mA (*7))									
Regenerative Resistor/ Tolerable Regenerative Power (W) (*3, *4)	Built-In Regenerative Resistor	15	15	100	100	130 (*9)	170 (*9)	-	-	-	
	External Regenerative Resistor (Standard Accessory) (*5, *6)	-	-	-	-	-	-	500 (800)	850 (1300)	850 (1300)	
Control System		Sine-wave PWM control/current control system									
Dynamic Brake		Built-in (*8, 10)						External option			
Safety Features		Overcurrent shutdown, regeneration overvoltage shutdown, overload shutdown (electronic thermal), servo motor overheat protection, encoder fault protection, regeneration fault protection, undervoltage/sudden power outage protection, overspeed protection, excess error protection									
Structure		Self-cooling open (IP00)			Fan cooling open (IP00)						
Environment	Ambient Temperature	0 to 55°C (32 to 131°F) (non-freezing), storage: -20 to 65°C (-4 to 149°F) (non-freezing)									
	Ambient Humidity	90% RH maximum (non-condensing), storage: 90% RH maximum (non-condensing)									
	Atmosphere	Indoors (no direct sunlight); no corrosive gas, inflammable gas, oil mist or dust									
	Elevation	1000m or less above sea level									
	Vibration	5.9m/s ² maximum									
Mass kg (lb)		1.7 (3.7)	1.7 (3.7)	2.1 (4.6)	4.6 (10)	4.6 (10)	6.2 (14)	18 (40)	18 (40)	19 (42)	

Notes:

- Rated output and rated speed of the servo motor used in combination with the servo amplifier are as indicated when using the power supply voltage and frequency listed. The torque drops when the power supply voltage is less than specified.
- For torque characteristics when combined with a servo motor, refer to the section "Servo motor torque characteristics" in the MR-J3 manual.
- Optimal regenerative resistor varies for each system. Select the most suitable regenerative resistor by using the capacity selection software.
- Refer to the section "Options • Optional regeneration unit" in the MR-J3 manual for the tolerable regenerative power (W).
- The servo amplifier (MR-J3-_{KB4-PX}) without an enclosed regenerative resistor is also available.
- The value in () applies when the external regenerative resistors, GRZG400-_Ω, (standard accessory) are used with cooling fans (2 units of 92 X 92mm, minimum air flow: 1.0m³/min). Note that change in the parameter No. PA02 is required.
- 150mA is the value when all of the input/output points are used. The current capacity can be stepped down according to the number of input/output points in use. Refer to "MR-J3-_B SAFETY SERVO AMPLIFIER INSTRUCTION MANUAL" for details.
- Special specification models without a dynamic brake, MR-J3-_{B4-ED}, are also available.
- The amplifier built-in resistor is compatible with the maximum torque deceleration when the motor is used within the rated speed and the recommended load/motor inertia moment ratio. Contact Mitsubishi if the operating motor speed and the load/motor inertia moment ratio exceed the rated speed and the recommended ratio.
- For the servo amplifier 5kW or 7kW, the load/motor of inertia moment ratio must be 5 times or less when the amplifier built-in dynamic brake is used, and the motor speed exceeds 2000r/min.

MR-J3-B Safety Servo Amplifier Specifications: 400VAC, 30kW or Larger

Drive Unit Model		MR-J3-DU30KBS4	MR-J3-DU37KBS4	MR-J3-DU45KBS4	MR-J3-DU55KBS4
Stock Item		-			
Main Circuit Power Supply	Voltage/Frequency (*1)	The drive unit's main circuit power is supplied from the converter unit.			
	Permissible Voltage Fluctuation				
	Permissible Frequency Fluctuation				
Control Circuit Power Supply	Voltage/Frequency	1-phase 380 to 480VAC 50/60Hz			
	Permissible Voltage Fluctuation	1-phase 323 to 528VAC			
	Permissible Frequency Fluctuation	±5% maximum			
	Power Consumption (W)	45			
Interface Power Supply		24VDC ±10% (required current capacity: 150mA (*2))			
Control System		Sine-wave PWM control/current control system			
Dynamic Brake		External option			
Safety Features		Overcurrent shutdown, overload shutdown (electronic thermal), servo motor overheat protection, encoder fault protection, undervoltage/sudden power outage protection, overspeed protection, excess error protection			
Structure		Fan cooling open (IP00)			
Mass kg (lb)		18 (40)		26 (57)	
Environment	Ambient Temperature	0 to 55°C (32 to 131°F) (non-freezing), storage: -20 to 65°C (-4 to 149°F) (non-freezing)			
	Ambient Humidity	90% RH maximum (non-condensing), storage: 90% RH maximum (non-condensing)			
	Atmosphere	Indoors (no direct sunlight); no corrosive gas, inflammable gas, oil mist or dust			
	Elevation	1000m or less above sea level			
	Vibration	5.9m/s ² maximum			

Notes:

- Rated output and rated speed of the servo motor used in combination with the drive unit and the converter unit are as indicated when using the power supply voltage and frequency listed. The torque drops when the power supply voltage is less than specified.
- The interface power supply can be shared with the drive unit and the converter unit. When all of the input/output points are used, 150mA is required for the drive unit, and 130mA is required for the converter unit. The current capacity can be stepped down according to the number of input/output points in use. Refer to "MR-J3-_B SAFETY SERVO AMPLIFIER INSTRUCTION MANUAL" for details.

MR-J3-D05 Safety Logic Unit Specifications (*4)

Servo Amplifier Model MR-J3-		MR-J3-D05
Stocked Item		S
Control Circuit Power Supply	Voltage	24VDC
	Permissible Voltage Fluctuation	24VDC±10%
	Required Current Capacity	500mA (*1, *2)
Compatible System		2 systems (A-axis, B-axis independent)
Shut-off Input		4 points (2 points x 2 systems) SDL_ : source/sink compatible (*3)
Shut-off Release Input		2 points (1 point x 2 systems) SRES_ : source/sink compatible (Note 3)
Feedback Input		2 points (1 point x 2 systems) TOF_ : source compatible (Note 3)
Input Method		Photocoupler insulation, 24VDC (external supply), internal limited resistance 5.4kΩ
Shut-off Output		8 points (4 points x 2 systems) STO_ : source compatible (*3) SDO_ : source/sink compatible (*3)
Output Method		Photocoupler insulation, Open collector. Permissible current: 40mA or less per output, Inrush current: 100mA or less per output
Response Performance (When Delay Time is Set to 0s)		20ms or less (STO input OFF - shut-off output OFF)
Delay Time Setting		A-axis: select from 0s, 1.4s, 2.8s, 5.6s, 9.8s or 30.8s; B-axis: select from 0s, 1.4s, 2.8s, 9.8s or 30.8s; Accuracy: ±2%
Safety Function		STO, SS1 (EN IEC 61800-5-2), EMG STOP, EMG OFF (EN IEC 60204-1)
Safety Performance		EN ISO 13849-1 PL d (Category 3), IEC/EN 61508 SIL 2, EN 62061 SIL CL 2
Structure		Self-cooling open (IP00)
Environment	Ambient Temperature	0 to 55°C (32 to 131°F) (non-freezing), storage: -20 to 65°C (-4 to 149°F) (non-freezing)
	Ambient Humidity	90% RH maximum (non-condensing), storage: 90% RH maximum (non-condensing)
	Atmosphere	Indoors (no direct sunlight); no corrosive gas, inflammable gas, oil mist or dust
	Elevation	1000m or less above sea level
	Vibration	5.9m/s ² or less at 10 to 55Hz (directions of X, Y and Z axes)
Mass kg (lb)		0.2 (0.44) (including CN9 and CN10 connectors)

Notes:

- Inrush current of approximately 1.5mA flows instantaneously when turning the control circuit power supply on. Select an appropriate capacity of a power supply considering the inrush current.
- Power-ON duration of the safety logic unit is 100,000 times.
- _ in signal name represents a symbol which indicates a system number and axis name.
- MR-J3B Safety amplifiers have STO built-in, the MR-J3-D05 is needed for the SSI function.

MR-J3W-B Servo Amplifier Specifications

Servo Amplifier Model MR-J3-		MR-J3W-22B		MR-J3W-44B		MR-J3W-77B	
Stock Item		S		S		S	
Rated Output Capacity		A-axis 200W	B-axis 200W	A-axis 400W	B-axis 400W	A-axis 750W	B-axis 750W
Output	Rated Voltage	3-phase 170VAC					
	Rated Current (A)	1.5	1.5	2.8	2.8	5.8	5.8
Main Circuit Power Supply	Voltage/Frequency (*1)	3-phase 200 to 230VAC 50/60Hz or 1-phase 200 to 230VAC 50/60Hz				3-phase 200 to 230VAC 50/60Hz	
	Rated Current (A)	3.5		6.1		10.4	
	Permissible Voltage Fluctuation	For 3-phase 200 to 230VAC: 3-phase 170 to 253VAC For 1-phase 200 to 230VAC: 1-phase 170 to 253VAC				3-phase 170 to 253VAC	
	Permissible Frequency Fluctuation	±5% maximum					
Control Circuit Power Supply	Voltage/Frequency	1-phase 200 to 230VAC 50/60Hz					
	Rated Current (A)	0.4					
	Permissible Voltage Fluctuation	1-phase 170 to 253VAC					
	Permissible Frequency Fluctuation	±5% maximum					
Power Consumption (W)		55					
Interface Power Supply		24VDC ±10% (required current capacity: 0.25A (*2))					
Tolerable Regenerative Power of Regenerative Resistor (W)	Built-In Regenerative Resistor		10		100		100
	Optional Regeneration Unit	MR-RB14	100		-		-
		MR-RB34	-		-		300
Control System		Sine-wave PWM control/current control system					
Dynamic Brake		Built-in (*3)					
Safety Features		Overcurrent shutdown, regeneration overvoltage shutdown, overload shutdown (electronic thermal), servo motor overheat protection, encoder fault protection, regeneration fault protection, undervoltage/sudden power outage protection, overspeed protection, excess error protection					
Structure		Self-cooling open (IP00)				Fan cooling open (IP00)	
Environment	Ambient Temperature (*4)	0 to 55°C (32 to 131°F) (non-freezing), storage: -20 to 65°C (-4 to 149°F) (non-freezing)					
	Ambient Humidity	90% RH maximum (non-condensing), storage: 90% RH maximum (non-condensing)					
	Atmosphere	Indoors (no direct sunlight); no corrosive gas, inflammable gas, oil mist or dust					
	Elevation	1000m or less above sea level					
	Vibration	5.9m/s ² maximum, 10 – 55Hz (X, Y, Z axes)					
Mass kg (lb)		1.4				2.3	

Notes:

- Rated output and speed of a rotary servo motor; and rated thrust and speed of a linear servo motor are applicable when the servo amplifier, combined with the servo motors or the linear servo motors, is operated within the specified power supply voltage and frequency. Torque drops when the power supply voltage is below the specified value.
- 0.25A is the value when all of the input/output points are used. The current capacity can be stepped down according to the number of input/output points in use.
- When using the built-in dynamic brake, refer to "MR-J3W-MB SERVO AMPLIFIER INSTRUCTION MANUAL" for permissible load inertia moment ratio.
- MR-J3W_B servo amplifiers can be mounted closely. In the case of MR-J3-44B, however, operate them at 90% or less of the effective load ratio.

MR-J3-T Servo Amplifier Specifications 100VAC/200VAC

Servo Amplifier Model MR-J3-		10T	20T	40T	60T	70T	100T	200T	350T	500T	700T	11KT	15KT	22KT	10T1	20T1	40T1	
Stock Item		S	S	S	S	S	S	S	S	S	S	-	-	-	S	S	S	
Main Circuit Power Supply	Voltage/Frequency (*1, *2)	3-phase 200 to 230VAC 50/60Hz or 1-phase 200 to 230VAC 50/60Hz (*10)						3-phase 200 to 230VAC 50/60Hz						1-phase 100 to 120VAC 50/60Hz				
	Permissible Voltage Fluctuation	For 3-phase 200 to 230VAC: 3-phase 170 to 253VAC For 1-phase 200 to 230VAC: 1-phase 170 to 253VAC						3-phase 170 to 253VAC						1-phase 85 to 132VAC				
	Permissible Freq. Fluctuation	±5% maximum																
Control Circuit Power Supply	Voltage/Frequency	1-phase 200 to 230VAC 50/60Hz (*10)					1-phase 200 to 230VAC 50/60Hz										1-phase 100 to 120VAC 50/60Hz	
	Permissible Voltage Fluctuation	1-phase 170 to 253VAC															1-phase 85 to 132VAC	
	Permissible Freq. Fluctuation	±5% maximum																
	Power Consumption (W)	30						45						30				
Interface Power Supply		24VDC ±10% (required current capacity: 150mA (*7))																
Regenerative Resistor/ Tolerable Regenerative Power (W) (*3, *4)	Built-In Regenerative Resistor	-	10	10	10	20	20	100	100	130	170	-	-	-	-	10	10	
	External Regenerative Resistor (Standard Accessory) (*5, *6)	-	-	-	-	-	-	-	-	-	-	500 (800)	850 (1300)	850 (1300)	-	-	-	
Control System		Sine-wave PWM control/current control system																
Dynamic Brake		Built-in (*8)										External option			Built-in (*8)			
Safety Features		Overcurrent shutdown, regeneration overvoltage shutdown, overload shutdown (electronic thermal), servo motor overheat protection, encoder fault protection, regeneration fault protection, undervoltage/sudden power outage protection, overspeed protection, excess error protection																
Structure		Self-cooling open (IP00)					Fan cooling open (IP00)										Self-cooling open (IP00)	
Environment	Ambient Temperature (*9)	0 to 55°C (32 to 131°F) (non-freezing), storage: -20 to 65°C (-4 to 149°F) (non-freezing)																
	Ambient Humidity	90% RH maximum (non-condensing), storage: 90% RH maximum (non-condensing)																
	Atmosphere	Indoors (no direct sunlight); no corrosive gas, inflammable gas, oil mist or dust																
	Elevation	1000m or less above sea level																
	Vibration	5.9m/s ² maximum																
Mass kg (lb)		0.8 (1.8)	0.8 (1.8)	1.0 (2.2)	1.0 (2.2)	1.4 (3.1)	1.4 (3.1)	2.1 (4.6)	2.3 (5.1)	4.6 (10)	6.2 (14)	18 (40)	18 (40)	19 (42)	0.8 (1.8)	0.8 (1.8)	1.0 (2.2)	

Notes:

- Rated output and rated speed of the servo motor used in combination with the servo amplifier are as indicated when using the power supply voltage and frequency listed. The torque drops when the power supply voltage is less than specified.
- For torque characteristics when combined with a servo motor, refer to the section "Servo motor torque characteristics" in the MR-J3 manual.
- Optimal regenerative resistor varies for each system. Select the most suitable regenerative resistor by using the capacity selection software.
- Refer to the section "Options • Optional regeneration unit" in the MR-J3 manual for the tolerable regenerative power (W).
- The servo amplifier (MR-J3- _KT-PX) without an enclosed regenerative resistor is also available.
- The value in () applies when the external regenerative resistors, GRZG400-Ω, (standard accessory) are used with cooling fans (2 units of 92 x 92mm, minimum air flow: 1.0m³/min). Note that change in the parameter No. PA02 is required.
- 150mA is the value when all of the input/output points are used. The current capacity can be stepped down according to the number of input/output points in use. Refer to "MR-J3- _T SERVO AMPLIFIER INSTRUCTION MANUAL" for details.
- Special specification models without a dynamic brake, MR-J3- _T-ED and MR-J3- _T1-ED, are also available.
- The MR-J3-350T or smaller servo amplifier can be installed closely. In this case, keep the ambient temperature within 0 to 45°C (32 to 113°F), or use the servo amplifier with 75% or less of the effective load rate.
- The special specification model, MR-J3- _T-U004, is also available for 1-phase 200 to 240VAC.

MR-J3-T Servo Amplifier Specifications 400VAC

Servo Amplifier Model MR-J3-		60T4	100T4	200T4	350T4	500T4	700T4	11KT4	15KT4	22KT4
Stock Item		S	S	S	S	S	S	-	-	-
Main Circuit Power Supply	Voltage/Frequency (*1, 2)	3-phase 380 to 480VAC 50/60Hz								
	Permissible Voltage Fluctuation	3-phase 323 to 528VAC								
	Permissible Frequency Fluctuation	±5% maximum								
Control Circuit Power Supply	Voltage/Frequency	1-phase 380 to 480VAC 50/60Hz								
	Permissible Voltage Fluctuation	1-phase 323 to 528VAC								
	Permissible Frequency Fluctuation	±5% maximum								
	Power Consumption (W)	30				45				
Interface Power Supply		24VDC ±10% (required current capacity: 150mA (*7))								
Regenerative Resistor/ Tolerable Regenerative Power (W) (*3, 4)	Built-In Regenerative Resistor	15	15	100	100	130 (*9)	170 (*9)	-	-	-
	External Regenerative Resistor (Standard Accessory) (*5, *6)	-	-	-	-	-	-	500 (800)	850 (1300)	850 (1300)
Control System		Sine-wave PWM control/current control system								
Dynamic Brake		Built-in (*8, *10)						External option		
Safety Features		Overcurrent shutdown, regeneration overvoltage shutdown, overload shutdown (electronic thermal), servo motor overheat protection, encoder fault protection, regeneration fault protection, undervoltage/sudden power outage protection, overspeed protection, excess error protection								
Structure		Self-cooling open (IP00)			Fan cooling open (IP00)					
Environment	Ambient Temperature	0 to 55°C (32 to 131°F) (non-freezing), storage: -20 to 65°C (-4 to 149°F) (non-freezing)								
	Ambient Humidity	90% RH maximum (non-condensing), storage: 90% RH maximum (non-condensing)								
	Atmosphere	Indoors (no direct sunlight); no corrosive gas, inflammable gas, oil mist or dust								
	Elevation	1000m or less above sea level								
	Vibration	5.9m/s ² maximum								
Mass kg (lb)		1.7 (3.7)	1.7 (3.7)	2.1 (4.6)	4.6 (10)	4.6 (10)	6.2 (14)	18 (40)	18 (40)	19 (42)

Notes:

- Rated output and rated speed of the servo motor used in combination with the servo amplifier are as indicated when using the power supply voltage and frequency listed. The torque drops when the power supply voltage is less than specified.
- For torque characteristics when combined with a servo motor, refer to the section "Servo motor torque characteristics" in the MR-J3 manual.
- Optimal regenerative resistor varies for each system. Select the most suitable regenerative resistor by using the capacity selection software.
- Refer to the section "Options • Optional regeneration unit" in the MR-J3 manual for the tolerable regenerative power (W).
- The servo amplifier (MR-J3- _KT4-PX) without an enclosed regenerative resistor is also available.
- The value in () applies when the external regenerative resistors, GRZG400-MQ, (standard accessory) are used with cooling fans (2 units of 92 x 92mm, minimum air flow: 1.0m³/min). Note that change in the parameter No. PA02 is required.
- 150mA is the value when all of the input/output points are used. The current capacity can be stepped down according to the number of input/output points in use. Refer to "MR-J3- _T SERVO AMPLIFIER INSTRUCTION MANUAL" for details.
- Special specification models without a dynamic brake, MR-J3- _T4-ED are also available.
- The amplifier built-in resistor is compatible with the maximum torque deceleration when the motor is used within the rated speed and the recommended load/motor inertia moment ratio. Contact Mitsubishi if the operating motor speed and the load/motor inertia moment ratio exceed the rated speed and the recommended ratio.
- For the servo amplifier 5kW or 7kW, the load/motor of inertia moment ratio must be 5 times or less when the amplifier built-in dynamic brake is used, and the motor speed exceeds 2000r/min.

MR-J3-D01 Specifications

Model		MR-J3-D01
Stock Item		S
Power Supply for Interface		24VDC ±10% (required current capacity: 800mA (*1, *2))
Digital Input		30 points, photocoupler insulation, sink/source compatible
Digital Output		16 points, photocoupler insulation, sink/source compatible
Analog Input		2ch, 0 to ±10VDC (input impedance: 10 to 12kΩ)
Analog Output		2ch, 0 to ±12VDC
Power Supply for Analog Input Signal		P15R: DC+15V, permissible current: 30mA; N12R: DC-12V, permissible current: 30mA (*5)
Structure		Self-cooling open (IP00)
Environment	Ambient Temperature	0 to 55°C (32 to 131°F) (non-freezing), storage: -20 to 65°C (-4 to 149°F) (non-freezing)
	Ambient Humidity	90% RH maximum (non-condensing), storage: 90% RH maximum (non-condensing)
	Atmosphere	Indoors (no direct sunlight); no corrosive gas, inflammable gas, oil mist or dust
	Elevation	1000m or less above sea level
	Vibration	5.9m/s ² maximum
Mass kg (lb)		140 (0.31)

Functions Connecting to MR-J3-_T_

Function	Description
Digital Input	Point table No. selection 1 to 8 (DI0 to DI7), Servo-on (SON), Reset (RES), External torque limit selection (TL), Internal torque limit selection (TL1), Manual pulse generator multiplication 1, 2 (TPO, TP1), Override selection (OVR), Automatic/manual selection (MD0), Temporary stop/restart (TSTP), Proportional control (PC), Forward rotation start (ST1), Reverse rotation start (ST2), Position data input 1 to 12 (POS0 to POS03, POS10 to POS13, POS20 to POS23), Position data input symbol+ (POSP), Clear (CR), Position data input symbol- (POSN), Strobe (STRB), Speed selection 1 to 3 (SP0 to SP2), Gain changing (CDP) (*3)
Digital Output	Alarm code (ACD0 to ACD3), M code (MCD00 to MCD03, MCD10 to MCD13), Temporary stop (PUS), Positioning complete (MEND), Phase match (CPO), In-position (INP), Position data request 1, 2 (PRQ1, PRQ2), Zero speed (ZSP), Torque limit in effect (TLC), Warning (WNG), Electromagnetic brake interlock (MBR), Dynamic brake interlock (DB), Battery warning (BWNG), Positioning range output (POT), Variable gain selection (CDPS), Command speed reached (SA), Point table No. output 1 to 8 (PT0 to PT7) (*3)
Analog Input	Override (VC) (-10 to +10VDC/0 to 200%) Analog torque limit (TLA) (0 to ±10VDC/maximum torque)
Analog Output	Analog monitor output (MO1, MO2) (*4)

Functions Connecting to MR-J3-_A_-RJ040

Function	Description	
Position Control Mode	Electric Gear Numerator Digital Input	The electric gear numerator can be set arbitrarily in 5-digit BCD or 16-bit binary.
	High Resolution Analog Torque Limit	The torque limit can be set according to the rotating direction. TLAP: 0 to +10VDC/maximum torque; Resolution: 12-bit (Standard: 10-bit) TLAN: 0 to -10VDC/maximum torque; Resolution: 12-bit (Standard: 10-bit)
Speed Control Mode	Digital Speed Command Input	The speed command can be set arbitrarily in 5-digit BCD or 12-bit (16-bit) binary.
	High Resolution Analog Torque Limit	The torque limit can be set according to the rotating direction. TLAP: 0 to +10VDC/maximum torque; Resolution: 16-bit (Standard: 14-bit) TLAN: 0 to -10VDC/maximum torque; Resolution: 16-bit (Standard: 14-bit)
Torque Control Mode	Digital Speed Limit Input	The speed limit can be set arbitrarily in 5-digit BCD or 12-bit (16-bit) binary.
	High Resolution Torque Command Input	External analog torque command (OTC) 0 to ±8VDC/maximum torque; Resolution: 12-bit (Standard: 10-bit)

Notes:

- 800mA is the value when all of the input/output points are used. The current capacity can be stepped down according to the number of input/output points in use. Refer to "MR-J3-nT MR-J3-D01 SERVO AMPLIFIER INSTRUCTION MANUAL" for details.
- A 24VDC power supply for input/output signals can be shared by the servo amplifier and MR-J3-D01. In this case, secure the power supply capacity corresponding to the points of the input/output signals to be used.
- The signal assignment can be changed by setting the parameters. Refer to "MR-J3-nT MR-J3-D01 SERVO AMPLIFIER INSTRUCTION MANUAL" for details.
- Analog monitor output can be selected by setting the parameter. Refer to "MR-J3-nT MR-J3-D01 SERVO AMPLIFIER INSTRUCTION MANUAL" for details.
- P15R can be used as a power supply for TLA and VC. N12R can be used as a power supply for VC. Note that the power voltage varies between -12 to -15V.









B Converter Unit (Required for 30KW ~ 55KW 200/400V amplifiers)

Converter Unit Model		MR-J3-CR55K (For 200VAC Only)	MR-J3-CR55K4 (For 400VAC Only)
Stock Item		-	-
Main Circuit Power Supply	Voltage/Frequency (*1, *2)	3-phase 200 to 230VAC 50/60Hz	3-phase 380 to 480VAC 50/60Hz
	Permissible Voltage Fluctuation	3-phase 170 to 253VAC	3-phase 323 to 528VAC
	Permissible Frequency Fluctuation	±5% maximum	
Control Circuit Power Supply	Voltage/Frequency	1-phase 200 to 230VAC 50/60Hz	1-phase 380 to 480VAC 50/60Hz
	Permissible Voltage Fluctuation	1-phase 170 to 253VAC	1-phase 323 to 528VAC
	Permissible Frequency Fluctuation	±5% maximum	
	Power Consumption (W)	45	
Interface Power Supply		24VDC ±10% (required current capacity: 130mA (*3))	
Safety Features		Regeneration overvoltage shutdown, regeneration fault protection, overload shutdown (electronic thermal), undervoltage/sudden power outage protection	
Structure		Fan cooling open (IP00)	
Mass kg (lb)		25 (55)	

Notes:

- Rated output and rated speed of the servo motor used in combination with the drive unit and the converter unit are as indicated when using the power supply voltage and frequency listed. The torque drops when the power supply voltage is less than specified.
- For torque characteristics when combined with a servo motor, refer to the section "Servo motor torque characteristics" in the MR-J3 manual.
- The interface power supply can be shared with the drive unit and the converter unit. When all of the input/output points are used, 150mA is required for the drive unit, and 130mA is required for the converter unit. The current capacity can be stepped down according to the number of input/output points in use. Refer to "MR-J3-_A/B_ SERVO AMPLIFIER INSTRUCTION MANUAL" for details.

MR-J3 Servomotors

Motor Series		Rated Speed (Max. r/min)	Rated Output Capacity (kW)	Electromagnetic Brake Available	Standards		Protective Degree	Features	Application Examples
					EN	UL / cUL			
Small Capacity	 HF-KP	3000 (6000)	5 Types (200V) 0.05, 0.1, 0.2, 0.4, 0.75	x	x	x	IP65 (*2)	Low inertia: perfect for general industrial machines	<ul style="list-style-type: none"> Belt Drive Robots Mounters Sewing Machines X-Y Tables Food Processing Machines Semiconductor manufacturing devices Knitting and embroidery machines
	 HF-MP								
Medium Capacity	 HF-SP	1000 (1500)	6 Types (200V) 0.5, 0.85, 1.2, 2.0, 3.0, 4.2	x	x	x	IP67 (*2)	Medium inertia: suitable for variable applications three models from low to high-speed are available	<ul style="list-style-type: none"> Material Handling Systems Robots X-Y Tables
		2000 (3000)	7 Types (200V) 0.5, 1.0, 1.5, 2.0, 3.5, 5.0, 7.0 7 Types (400V) 0.5, 1.0, 1.5, 2.0, 3.5, 5.0, 7.0	x	x	x	IP67 (*2)		
	 HC-LP	2000 (3000)	5 Types (200V) 0.5, 1.0, 1.5, 2.0, 3.0	x	x	x	IP65 (*2)	Low inertia: perfect for general industrial machines	<ul style="list-style-type: none"> Roller feeder Loader and unloader High frequency material handling systems
	 HC-RP	3000 (4500)	5 Types (200V) 1.0, 1.5, 2.0, 3.5, 5.0	x	x	x	IP65 (*2)	Ultra-low inertia: well suited for high- frequency	<ul style="list-style-type: none"> Ultra-high frequency material handling systems
Flat, Small/ Medium Capacity	 HC-UP	2000 (3000: 0.75 ~ 2kW; 2500: 3.5, 5kW)	5 Types (200V) 0.75, 1.5, 2.0, 3.5, 5.0	x	x	x	IP65 (*2)	Flat type: well suited for situations where the installation space is restricted	<ul style="list-style-type: none"> Robots Food processing machines
Medium/ Large Capacity	 HF-JP	3000 (6000)	7 Types (200V) 0.5, 0.75, 1.0, 1.5, 2.0, 3.5, 5.0 7 Types (400V) 0.5, 0.75, 1.0, 1.5, 2.0, 3.5, 5.0	x	-	-	IP67	Low inertia: well suited for high-thruoutput and high-acceleration/ deceleration operations	<ul style="list-style-type: none"> Food processing machines Printing machines
		1500 (3000)	2 Types (200V) 11, 15 2 Types (400V) 11, 15	x	-	-	IP67		<ul style="list-style-type: none"> Injection molding machines Large press machines
	 HA-LP	1000 (1200)	8 Types (200V) 6.0, 8.0, 12, 15, 20, 25, 30, 37 8 Types (400V) 6.0, 8.0, 12, 15, 20, 25, 30, 37	x (6.0 ~ 12kW only)	x (*4)	x (*4)	IP44 (*2)	Low inertia: suitable for variable applications three models from low to medium-speed are available. As a standard, 30kW and larger capacities are compatible with flange mounting or foot mounting	<ul style="list-style-type: none"> Injection molding machines Semiconductor manufacturing devices Large material handling systems
			1500 (2000)	6 Types (200V) 7.0, 11, 15, 22, 30, 37 8 Types (400V) 7.0, 11, 15, 22, 30, 37, 45, 50	x (7.0 ~ 15kW only)	x (*4)	x (*4)		
		2000 (2000)		7 Types (200V) 5.0, 7.0, 11, 15, 22, 30, 37 7 Types (400V) 11, 15, 22, 30, 37, 45, 55	x (11 ~ 22kW only)	x (*4)	x (*4)		
	Third Party Motor		Exlar Actuator models GSX20, GSX30, GSX40, GSX50, GSX60. Order directly through Exlar Corporation www.exlar.com Select Amplifiers and Cables from Mitsubishi.						









Notes:

- "x" indicates the available product range.
- The shaft-through portion is excluded.
- Some motors from 15 to 25kW capacities can be mounted with the feet. Refer to the Motor Dimensions of this catalog.
- Some motors are under application for EN, UL, and cUL standards. Contact MEAU for more details.

200V Motor Selection: (Example Part# = HF-SP102BK)

Not all options are available for every motor.

H □ - □ P - □ □ □ □ □ - □

Symbol	Motor Series	
HF-KP	Low inertia, small capacity	
HF-MP	Ultra-low inertia, small capacity	
HF-SP	Medium inertia, medium capacity	
HF-JP	Ultra-low inertia, medium capacity	
HC-LP	Low inertia, medium capacity	
HC-RP	Ultra-low inertia, medium capacity	
HC-UP	Flat type Small/medium capacity	
HA-LP	Low inertia Medium/large capacity	

Symbol	Special Specification
LR	With enclosed regeneration resistor (*1)
LW	Without enclosed regeneration resistor

Note:
1. Standard with MR-J3-B Safety 11kW and 15kW.

Symbol	Shaft Shape
None	Standard (Straight)
K	With Keyway (*1)
D	D-Cut (*1)

Note:
1. Refer to Motor Shaft Detail in this section for compatible models and specifications.

Symbol	Oil Seal
None	None
J	Oil Seal Installed (*1, *2)

Note:
1. Dimensions for HF-KP/MP motors with oil seals are different than standard models. Contact Mitsubishi for details.
2. Oil-Seal not available for the 0.05kW motors.

Symbol	Electromagnetic Brake
None	None
B	With Brake

Symbol	Rated Speed (r/min)
1	1000 (*1)
1M	1500 (*1)
2	2000 (*1)
3	3000 (*1)

Note:
1. Refer to motor specifications in this catalog for correct symbol to use for each servo motor.

Symbol	Rated Output (kW)
05	0.05
1 to 8	0.1 to 0.85
10 to 80	1.0 to 8.0
11K to 37K	11.0 to 37.0

Model Number
HA-LP11K1MBK
HA-LP11K2BK
HA-LP11K2K
HA-LP15K2BK
HA-LP15K2K
HA-LP22K2BK
HA-LP22K2K

Model Number
HC-RP103BK
HC-RP103K
HC-RP153K
HC-RP353BK
HC-RP353K
HC-RP503K

Model Number
HC-UP72BK
HC-UP72K
HC-UP152BK
HC-UP152K
HC-UP202BK
HC-UP202K
HC-UP352BK
HC-UP352K
HC-UP502BK
HC-UP502K

Model Number
HF-JP53BK
HF-JP53K
HF-JP73BK
HF-JP73K
HF-JP103BK
HF-JP103K
HF-JP153BK
HF-JP153K
HF-JP203BK
HF-JP203K
HF-JP353BK
HF-JP353K
HF-JP503BK
HF-JP503K

Model Number
HF-JP153BK
HF-JP153K
HF-JP203BK
HF-JP203K
HF-JP353BK
HF-JP353K
HF-JP503BK
HF-JP503K

Model Number
HF-KP053
HF-KP053B
HF-KP13
HF-KP13B
HF-KP13D
HF-KP23
HF-KP23B
HF-KP23K
HF-KP43BK
HF-KP43K
HF-KP73BK
HF-KP73K

Model Number
HF-MP053
HF-MP053B
HF-MP13
HF-MP13B
HF-MP23BK
HF-MP23K
HF-MP43BK
HF-MP43K
HF-MP73BK
HF-MP73K

Model Number
HF-SP51BK
HF-SP51K
HF-SP52BK
HF-SP52K
HF-SP81BK
HF-SP81K
HF-SP102BK
HF-SP102K
HF-SP121BK
HF-SP121K
HF-SP152BK
HF-SP152K
HF-SP202BK
HF-SP202K
HF-SP352BK
HF-SP352K
HF-SP502BK
HF-SP502K
HF-SP702BK
HF-SP702K

400V Motor Selection: (Example Part# = HF-SP524BK)

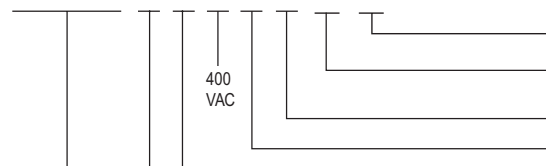

Not all options are available for every motor.

H □ - □ P - □ □ □ 4 □ □ □ □ - □



Symbol	Rated Output (kW)
5	0.5
10 to 80	1.0 to 8.0
11K to 55K	11.0 to 55.0

Note:
1. Refer to motor specifications in this catalog for correct symbol to use for each servo motor.

Symbol	Motor Series	
HF-SP	Medium inertia, medium capacity	
HF-JP	Ultra-low inertia, medium capacity	
HA-LP	Low inertia, medium/large capacity	

Symbol	Special Specification
LR	With enclosed regeneration resistor (*1)
LW	Without enclosed regeneration resistor

Note:
1. Standard with MR-J3-B Safety 11kW and 15kW.

Symbol	Shaft Shape
None	Standard (Straight)
K	With Keyway (*1)

Note:
1. Refer to Motor Shaft Detail in this section for compatible models and specifications.

Symbol	Oil Seal
None	None
J	Oil Seal Installed (*1)

Note:
1. Oil-Seal not available for the 0.05kW motors.

Symbol	Electromagnetic Brake
None	None
B	With Brake

Symbol	Rated Speed (r/min)
1	1000 (*1)
1M	1500 (*1)
2	2000 (*1)

Note:
1. Refer to motor specifications in this catalog for correct symbol to use for each servo motor.

Model Number
HA-LP701M4BK
HA-LP701M4K
HA-LP11K1M4K
HA-LP11K24BK
HA-LP11K24K
HA-LP15K1M4BK
HA-LP15K1M4K
HA-LP15K24BK
HA-LP15K24K
HA-LP22K1M4K
HA-LP22K24BK
HA-LP22K24K

Model Number
HF-SP524BK
HF-SP524K
HF-SP1024BK
HF-SP1024K
HF-SP1524BK
HF-SP1524K
HF-SP2024BK
HF-SP2024K
HF-SP3524BK
HF-SP3524K
HF-SP5024BK
HF-SP5024K
HF-SP7024BK
HF-SP7024K

Model Number
HF-JP534BK
HF-JP534K
HF-JP734BK
HF-JP734K
HF-JP1034BK
HF-JP1034K
HF-JP2034BK
HF-JP2034K
HF-JP3534BK
HF-JP3534K
HF-JP5034BK
HF-JP5034K
HF-JP11K1M4K
HF-JP1534BK
HF-JP1534K
HF-JP15K1M4BK
HF-JP15K1M4K

HF-KP Series 200V Servomotor Specifications

Servomotor Model HF-KP_		053(B)	13(B)	23(B)	43(B)	73(B)
Servo Amplifier Model MR-J3-_-		10A(1)(-RJ070)/BS(1)/T(1)/W-22B		20A(1)(-RJ070)/BS(1)/T(1)/W-22B/W-44B	40A(1)(-RJ070)/BS(1)/T(1)/W-44B/W-77B	70A(-RJ070)/BS/T/W-77B
Power Facility Capacity (kVA) (*1)		0.3	0.3	0.5	0.9	1.3
Continuous Running Duty	Rated Output (W)	50	100	200	400	750
	Rated Torque (N•m [oz•in])	0.16 (22.7)	0.32 (45.3)	0.64 (90.6)	1.3 (184)	2.4 (340)
Maximum Torque (N•m [oz•in])		0.48 (68)	0.95 (135)	1.9 (269)	3.8 (538)	7.2 (1020)
Rated Speed (r/min)		3000				
Maximum Speed (r/min)		6000				
Permissible Instantaneous Speed (r/min)		6900				
Power Rate at Continuous Rated Torque (kW/s)		4.87	11.5	16.9	38.6	39.9
Rated Current (A)		0.9	0.8	1.4	2.7	5.2
Maximum Current (A)		2.7	2.4	4.2	8.1	15.6
Regenerative Braking Frequency (*2) (times/min)		Refer to Manual	Refer to Manual	448	249	140
Moment of Inertia J (x10 ⁻⁴ kg•m ²) [J (oz•in ²)]	Standard	0.052 (0.284)	0.088 (0.481)	0.24 (1.31)	0.42 (2.30)	1.43 (7.82)
	With Electromagnetic Brake	0.054 (0.295)	0.090 (0.492)	0.31 (1.69)	0.50 (2.73)	1.63 (8.91)
Recommended Load / Motor Inertia Moment Ratio (*3)		15 times maximum		24 times maximum	22 times maximum	15 times maximum
Speed/Position Detector		18-bit encoder (Resolution per encoder/servomotor rotation: 262144p/rev)				
Attachments		-	Motors with an oil seal are available (HF-KP_J)			
Insulation Class		Class B				
Structure		Totally enclosed non-ventilated (protection level: IP65) (*4)				
Environment	Ambient Temperature	0 to 40°C (32 to 104°F) (non-freezing), storage: -15 to 70°C (5 to 158°F) (non-freezing)				
	Ambient Humidity	80% RH maximum (non-condensing), storage: 90% RH maximum (non-condensing)				
	Atmosphere	Indoors (no direct sunlight); no corrosive gas, inflammable gas, oil mist or dust				
	Elevation / Vibration	1000m or less above sea level / X,Y:49m/s ²				
Mass kg (lb)	Standard	0.35 (0.78)	0.56 (1.3)	0.94 (2.1)	1.5 (3.3)	2.9 (6.4)
	With Electromagnetic Brake	0.65 (1.5)	0.86 (1.9)	1.6 (3.6)	2.1 (4.7)	3.9 (8.6)

Notes:

- The power facility capacity varies depending on the power supply's impedance.
- The regenerative braking frequency shows the permissible frequency for decelerating the motor without a load and the optional regeneration unit from the rated speed to a stop.
- Contact Mitsubishi if the load/motor of inertia moment ratio exceeds the value in the table.
- The shaft-through portion is excluded.

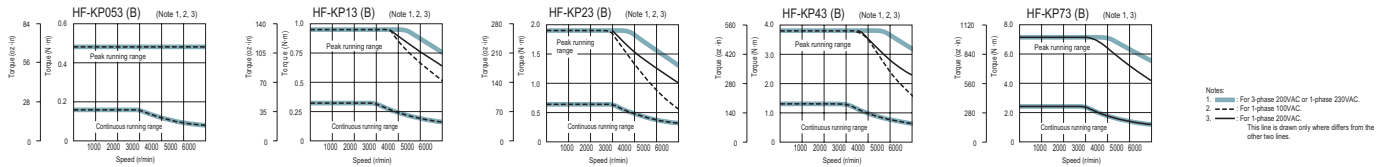

HF-MP Series 200V Servomotor Specifications

Servomotor Model HF-MP_		053(B)	13(B)	23(B)	43(B)	73(B)
Servo Amplifier Model MR-J3-_-		10A(1)(-RJ070)/ BS(1)/T(1)/W-22B		20A(1)(-RJ070)/ BS(1)/T(1)/W-22B/W-44B	40A(1)(-RJ070)/ BS(1)/T(1)/W-44B/W-77B	70A(-RJ070)/BS/T/W-77B
Power Facility Capacity (kVA) (*1)		0.3	0.3	0.5	0.9	1.3
Continuous Running Duty	Rated output (W)	50	100	200	400	750
	Rated torque (N•m [oz•in])	0.16 (22.7)	0.32 (45.3)	0.64 (90.6)	1.3 (184)	2.4 (340)
Maximum Torque (N•m [oz•in])		0.48 (68)	0.95 (135)	1.9 (269)	3.8 (538)	7.2 (1020)
Rated Speed (r/min)		3000				
Maximum Speed (r/min)		6000				
Permissible Instantaneous Speed (r/min)		6900				
Power Rate at Continuous Rated Torque (kW/s)		13.3	31.7	46.1	111.6	95.5
Rated Current (A)		1.1	0.9	1.6	2.7	5.6
Maximum Current (A)		3.2	2.8	5.0	8.6	16.7
Regen Braking Frequency (*2) (times/min)		Refer to Manual	Refer to Manual	1570	920	420
Moment of Inertia J (x10 ⁻⁴ kg•m ²) [J (oz•in ²)]	Standard	0.019 (0.104)	0.032 (0.175)	0.088 (0.481)	0.15 (0.82)	0.60 (3.28)
	With Electromagnetic Brake	0.025 (0.137)	0.039 (0.213)	0.12 (0.656)	0.18 (0.984)	0.70 (3.83)
Recommended Load/Motor Inertia Moment Ratio		30 times the servomotor's inertia moment maximum (*3)				
Speed/Position Detector		18-bit encoder (Resolution per encoder/servomotor rotation: 262144p/rev)				
Attachments		-	- Motors with an oil seal are available (HF-MP_J)			
Insulation Class		Class B				
Structure		Totally enclosed non-ventilated (protection level: IP65) (*4)				
Environment	Ambient Temperature	0 to 40°C (32 to 104°F) (non-freezing), storage: -15 to 70°C (5 to 158°F) (non-freezing)				
	Ambient Humidity	80% RH maximum (non-condensing), storage: 90% RH maximum (non-condensing)				
	Atmosphere	Indoors (no direct sunlight); no corrosive gas, inflammable gas, oil mist or dust				
	Elevation / Vibration	1000m or less above sea level / X, Y: 49m/s ²				
Mass kg (lb)	Standard	0.35 (0.78)	0.56 (1.3)	0.94 (2.1)	1.5 (3.3)	2.9 (6.4)
	With electromagnetic brake	0.65 (1.5)	0.86 (1.9)	1.6 (3.6)	2.1 (4.7)	3.9 (8.6)

Notes:

- The power facility capacity varies depending on the power supply's impedance.
- The regenerative braking frequency shows the permissible frequency for decelerating the motor without a load and the optional regeneration unit from the rated speed to a stop.
- Contact Mitsubishi if the load/motor of inertia moment ratio exceeds the value in the table.
- The shaft-through portion is excluded.

HF-MP Series 200V Servomotor Speed Torque Curves

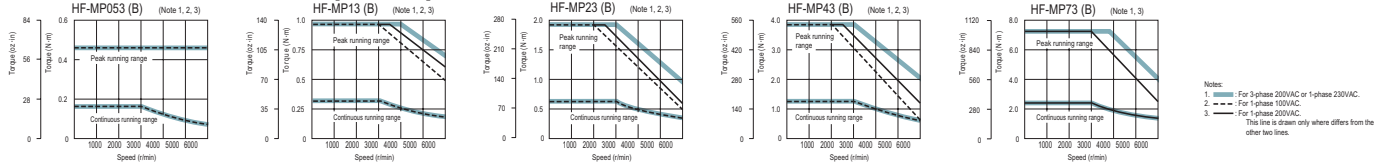

HF-SP 1000r/min Series 200V Servomotor Specifications

Servomotor Model HF-SP_	51(B)	81(B)	121(B)	201(B)	301(B)	421(B)	
Servo Amplifier Model MR-J3- _ _	60A(-RJ070)/60BS/T (*6)	100A(-RJ070)/BS/T (*6)	200A(-RJ070)/BS/T	350A(-RJ070)/BS/T (*6)	500A(-RJ070)/BS/T (*6)		
Power Facility Capacity (kVA) (*1)	1.0	1.5	2.1	3.5	4.8	6.3	
Continuous Running Duty	Rated Output (kW)	0.5	0.85	1.2	2.0	3.0	4.2
	Rated Torque (N•m [oz•in])	4.77 (675)	8.12 (1150)	11.5 (1630)	19.1 (2700)	28.6 (4050)	40.1 (5679)
Maximum Torque (N•m [oz•in])	14.3 (2030)	24.4 (3460)	34.4 (4870)	57.3 (8110)	85.9 (12200)	120 (17000)	
Rated Speed (r/min)	1000						
Maximum Speed (r/min)	1500						
Permissible Instantaneous Speed (r/min)	1725						
Power Rate at Continuous Rated Torque (kW/s)	19.2	37.0	34.3	48.6	84.6	104	
Rated Current (A)	2.9	4.5	6.5	11	16	24	
Maximum Current (A)	8.7	13.5	19.5	33	48	72	
Regenerative Braking Frequency (Times/Min) (*2)	36	90	188	105	84	75	
Moment Of Inertia J (x10 ⁻⁴ kg•m ²) [J (oz•in ²)]	Standard	11.9 (65.1)	17.8 (97.3)	38.3 (290)	75.0 (410)	97.0 (530)	154 (842)
	With Electromagnetic Brake	14.0 (76.5)	20.0 (109)	47.9 (262)	84.7 (463)	107 (585)	164 (897)
Recommended Load/Motor Inertia Moment Ratio	15 times the servomotor's inertia moment maximum (*3)						
Speed/Position Detector	18-bit encoder (Resolution per encoder/servomotor rotation: 262144p/rev)						
Attachments	Motors with an oil seal are available (HF-SP_J)						
Insulation Class	Class F						
Structure	Totally enclosed non-ventilated (protection level: IP67) (*4)						
Environment	Ambient Temperature	0 to 40°C (32 to 104°F) (non-freezing), storage: -15 to 70°C (5 to 158°F) (non-freezing)					
	Ambient Humidity	80% RH maximum (non-condensing), storage: 90% RH maximum (non-condensing)					
	Atmosphere	Indoors (no direct sunlight); no corrosive gas, inflammable gas, oil mist or dust					
	Elevation / Vibration (*5)	1000m or less above sea level X: 24.5m/s ² Y: 24.5m/s ²	1000m or less above sea level X: 24.5m/s ² Y: 49m/s ²	1000m or less above sea level X: 24.5m/s ² Y: 29.4m/s ²			
Mass kg (lb)	Standard	6.5 (15)	8.3 (19)	12 (27)	19 (42)	22 (49)	32 (71)
	With Electromagnetic Brake	8.5 (19)	10.3 (23)	18 (40)	25 (56)	28 (62)	38 (84)

Notes:

- The power facility capacity varies depending on the power supply's impedance.
- The regenerative braking frequency shows the permissible frequency for decelerating the motor without a load and the optional regeneration unit from the rated speed to a stop.
- Contact Mitsubishi if the load/motor of inertia moment ratio exceeds the value in the table.
- The shaft-through portion is excluded.
- The vibration direction is shown in the right-side diagram. The numeric value indicates the maximum value of the component (commonly the bracket in the opposite direction of the motor shaft). Fretting of the bearing occurs easily when the motor stops, so maintain vibration to approximately one-half of the allowable value.

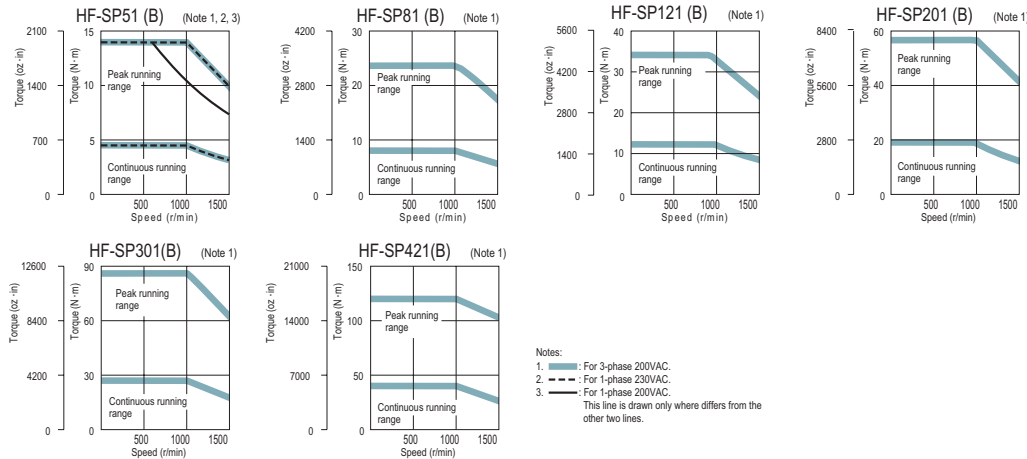

HF-SP 2000r/min Series 200V Servomotor Specifications

Servomotor Model HF-SP_	52(B)	102(B)	152(B)	202(B)	352(B)	502(B)	702(B)	
Servo Amplifier Model MR-J3_-_-	60A(-RJ070)/BS/T	100A(-RJ070)/BS/T	200A(-RJ070)/BS/T		350A(-RJ070)/BS/T	500A(-RJ070)/BS/T	700A(-RJ070)/BS/T	
Power Facility Capacity (kVA) (*1)	1.0	1.7	2.5	3.5	5.5	7.5	10	
Continuous Running Duty	Rated Output (kW)	0.5	1.0	1.5	2.0	3.5	5.0	7.0
	Rated Torque (N•m [oz•in])	2.39 (338)	4.77 (675)	7.16 (1010)	9.55 (1350)	16.7 (2360)	23.9 (3380)	33.4 (4730)
Maximum Torque (N•m [oz•in])	7.16 (1010)	14.3 (2020)	21.5 (3040)	28.6 (4050)	50.1 (7090)	71.6 (10100)	100 (14200)	
Rated Speed (r/min)	2000							
Maximum Speed (r/min)	3000							
Permissible Instantaneous Speed (r/min)	3450							
Power Rate Continuous Rated Torque (kW/s)	9.34	19.2	28.8	23.8	37.2	58.8	72.5	
Rated Current (A)	2.9	5.3	8.0	10	16	24	33	
Maximum Current (A)	8.7	15.9	24	30	48	72	99	
Regenerative Braking Frequency (times/min) (*2)	60	62	152	71	33	37	31	
Moment of inertia J (x10 ⁻⁴ kg•m ²) [J (oz•in ²)]	Standard	6.1 (33.4)	11.9 (65.1)	17.8 (97.3)	38.3 (209)	75.0 (410)	97.0 (530)	154 (842)
	With Electromagnetic Brake	8.3 (45.4)	14.0 (76.5)	20.0 (109)	47.9 (262)	84.7 (463)	107 (585)	164 (897)
Recommended Load/Motor Inertia Moment Ratio	15 times the servomotor's inertia moment maximum (*3)							
Speed/Position Detector	18-bit encoder (Resolution per encoder/servomotor rotation: 262144 p/rev)							
Attachments	Motors with an oil seal are available (HF-SP_J)							
Insulation Class	Class F							
Structure	Totally enclosed non-ventilated (protection level: IP67) (*4)							
Environment	Ambient Temperature	0 to 40°C (32 to 104°F) (non-freezing), storage: -15 to 70°C (5 to 158°F) (non-freezing)						
	Ambient Humidity	80% RH maximum (non-condensing), storage: 90% RH maximum (non-condensing)						
	Atmosphere	Indoors (no direct sunlight); no corrosive gas, inflammable gas, oil mist or dust						
Elevation / Vibration (*5)	1000m or less above sea level X: 24.5m/s ² Y: 24.5m/s ²			1000m or less above sea level X: 24.5m/s ² Y: 49m/s ²		1000m or less above sea level X: 24.5m/s ² Y: 29.4m/s ²		
	Standard	4.8 (11)	6.5 (15)	8.3 (19)	12 (27)	19 (42)	22 (49)	32 (71)
Mass kg (lb)	Standard	4.8 (11)	6.5 (15)	8.3 (19)	12 (27)	19 (42)	22 (49)	32 (71)
	With Electromagnetic Brake	6.7 (15)	8.5 (19)	10.3 (23)	18 (40)	25 (56)	28 (62)	38 (84)

Notes:

- The power facility capacity varies depending on the power supply's impedance.
- The regenerative braking frequency shows the permissible frequency for decelerating the motor without a load and the optional regeneration unit from the rated speed to a stop.
- Contact Mitsubishi if the load/motor of inertia moment ratio exceeds the value in the table.
- The shaft-through portion is excluded.
- The vibration direction is shown in the right-side diagram. The numeric value indicates the maximum value of the component (commonly the bracket in the opposite direction of the motor shaft). Fretting of the bearing occurs easily when the motor stops, so maintain vibration to approximately one-half of the allowable value.

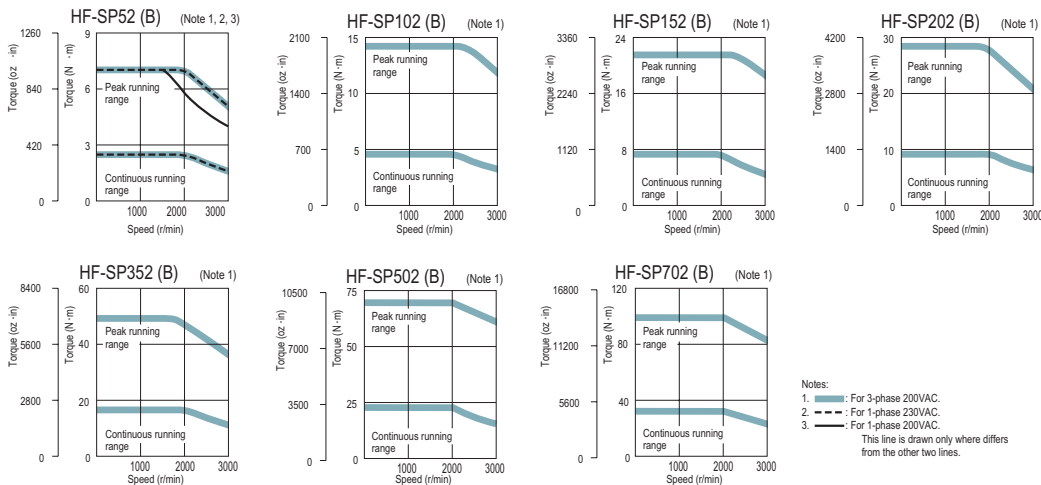

HF-SP 2000r/min Series 400V Servomotor Specifications

Servomotor Model HF-SP_	524(B)	1024(B)	1524(B)	2024(B)	3524(B)	5024(B)	7024(B)	
Servo Amplifier Model MR-J3-_-_-	60A4(-RJ070)/BS4/T4	100A4(-RJ070)/BS4/T4	200A4(-RJ070)/BS4/T4		350A4(-RJ070)/BS4/T4	500A4(-RJ070)/BS4/T4	700A4(-RJ070)/BS4/T4	
Power Facility Capacity (kVA) (*1)	1.0	1.7	2.5	3.5	5.5	7.5	10	
Continuous Running Duty	Rated Output (kW)	0.5	1.0	1.5	2.0	3.5	5.0	7.0
	Rated Torque (N•m [oz•in])	2.39 (338)	4.77 (675)	7.16 (1010)	9.55 (1350)	16.7 (2360)	23.9 (3380)	33.4 (4730)
Maximum Torque (N•m [oz•in])	7.16 (1010)	14.3 (2020)	21.5 (3040)	28.6 (4050)	50.1 (7090)	71.6 (10100)	100 (14200)	
Rated Speed (r/min)	2000							
Maximum Speed (r/min)	3000							
Permissible Instantaneous Speed (r/min)	3450							
Power Rate Continuous Rated Torque (kW/s)	9.34	19.2	28.8	23.8	37.2	58.8	72.5	
Rated Current (A)	1.5	2.9	4.1	5.0	8.4	12	16	
Maximum Current (A)	4.5	8.7	12	15	25	36	48	
Regenerative Braking Freq. (times/min) (*2)	90	46	154	72	37	34	28	
Moment of inertia J (x10 ⁻⁴ kg•m ²) [J (oz•in ²)]	Standard	6.1 (33.4)	11.9 (65.1)	17.8 (97.3)	38.3 (209)	75.0 (410)	97.0 (530)	154 (842)
	With Electromagnetic Brake	8.3 (45.4)	14.0 (76.5)	20.0 (109)	47.9 (262)	84.7 (463)	107 (585)	164 (897)
Recommended Load / Motor Inertia Moment Ratio	15 times the servomotor's inertia moment maximum (*3)							
Speed/Position Detector	18-bit encoder (Resolution per encoder/servomotor rotation: 262144 p/rev)							
Attachments	Motors with an oil seal are available (HF-SP_J)							
Insulation Class	Class F							
Structure	Totally enclosed non-ventilated (protection level: IP67) (*4)							
Environment	Ambient Temperature	0 to 40°C (32 to 104°F) (non-freezing), storage: -15 to 70°C (5 to 158°F) (non-freezing)						
	Ambient Humidity	80% RH maximum (non-condensing), storage: 90% RH maximum (non-condensing)						
	Atmosphere	Indoors (no direct sunlight); no corrosive gas, inflammable gas, oil mist or dust						
	Elevation / Vibration (*5)	1000m or less above sea level X: 24.5m/s ² Y: 24.5m/s ²		1000m or less above sea level X: 24.5m/s ² Y: 49m/s ²		1000m or less above sea level X: 24.5m/s ² Y: 29.4m/s ²		
Mass kg (lb)	Standard	4.8 (11)	6.7 (15)	8.5 (19)	13 (29)	19 (42)	22 (49)	32 (71)
	With Electromagnetic Brake	6.7 (15)	8.6 (19)	11 (25)	19 (42)	25 (56)	28 (62)	38 (84)

Notes:

- The power facility capacity varies depending on the power supply's impedance.
- The regenerative braking frequency shows the permissible frequency for decelerating the motor without a load and the optional regeneration unit from the rated speed to a stop.
- Contact Mitsubishi if the load/motor of inertia moment ratio exceeds the value in the table.
- The shaft-through portion is excluded.
- The vibration direction is shown in the right-side diagram. The numeric value indicates the maximum value of the component (commonly the bracket in the opposite direction of the motor shaft). Fretting of the bearing occurs easily when the motor stops, so maintain vibration to approximately one-half of the allowable value.

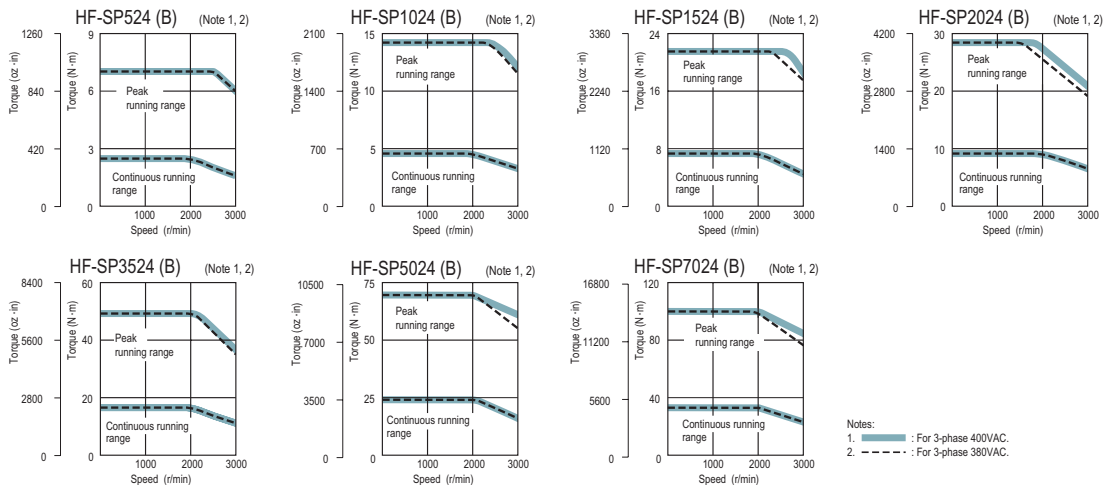

HC-LP Series 200V Servomotor Specifications

Servomotor Model HC-LP_		52(B)	102(B)	152(B)	202(B)	302(B)
Servo Amplifier Model MR-J3-_-		60A(-RJ070)/BS/T	100A(-RJ070)/BS/T	200A(-RJ070)/BS/T	350A(-RJ070)/BS/T	500A(-RJ070)/BS/T
Power Facility Capacity (kVA) (*1)		1.0	1.7	2.5	3.5	4.8
Continuous Running Duty	Rated Output (kW)	0.5	1.0	1.5	2.0	3.0
	Rated Torque (N•m [oz•in])	2.39 (338)	4.78 (677)	7.16 (1010)	9.55 (1350)	14.3 (2020)
Maximum Torque (N•m [oz•in])		7.16 (1010)	14.4 (2040)	21.6 (3060)	28.5 (4040)	42.9 (6070)
Rated Speed (r/min)		2000				
Maximum Speed (r/min)		3000				
Permissible Instantaneous Speed (r/min)		3450				
Power Rate At Continuous Rated Torque (kW/s)		18.4	49.3	79.8	41.5	56.8
Rated Current (A)		3.2	5.9	9.9	14	23
Maximum Current (A)		9.6	18	30	42	69
Regenerative Braking Frequency (Times/Min) (*2)		115	160	425	120	70
Moment Of Inertia J (x10 ⁻⁴ kg•m ²) [J (oz•in ²)]	Standard	3.10 (16.9)	4.62 (25.3)	6.42 (35.1)	22.0 (120)	36.0 (197)
	With Electromagnetic Brake	5.20 (28.4)	6.72 (36.7)	8.52 (46.6)	32.0 (175)	46.0 (252)
Recommended Load/Motor Inertia Moment Ratio		10 times the servomotor's inertia moment maximum (*3)				
Speed/Position Detector		18-bit encoder (Resolution per encoder/servomotor rotation: 262144p/rev)				
Attachments		Oil seal				
Insulation Class		Class F				
Structure		Totally enclosed non-ventilated (protection level: IP65) (*4)				
Environment	Ambient Temperature	0 to 40°C (32 to 104°F) (non-freezing), storage: -15 to 70°C (5 to 158°F) (non-freezing)				
	Ambient Humidity	80% RH maximum (non-condensing), storage: 90% RH maximum (non-condensing)				
	Atmosphere	Indoors (no direct sunlight); no corrosive gas, inflammable gas, oil mist or dust				
	Elevation / Vibration (*5)	1000m or less above sea level X: 9.8m/s ² Y: 24.5m/s ²			1000m or less above sea level X: 19.6m/s ² Y: 49m/s ²	
Mass kg (lb)	Standard	6.5 (15)	8.0 (18)	10 (22)	21 (47)	28 (62)
	With Electromagnetic Brake	9.0 (20)	11 (25)	13 (29)	27 (60)	34 (75)

Notes:

- The power facility capacity varies depending on the power supply's impedance.
- The regenerative braking frequency shows the permissible frequency for decelerating the motor without a load and the optional regeneration unit from the rated speed to a stop.
- Contact Mitsubishi if the load/motor of inertia moment ratio exceeds the value in the table.
- The shaft-through portion is excluded.
- The vibration direction is shown in the right-side diagram. The numeric value indicates the maximum value of the component (commonly the bracket in the opposite direction of the motor shaft). Fretting of the bearing occurs easily when the motor stops, so maintain vibration to approximately one-half of the allowable value

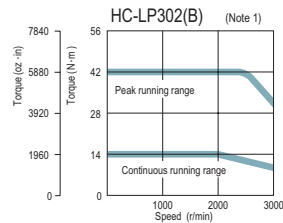
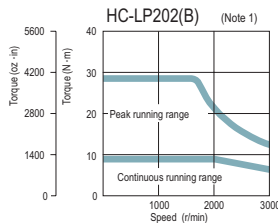
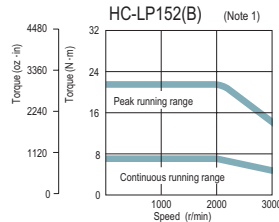
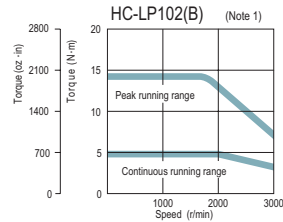
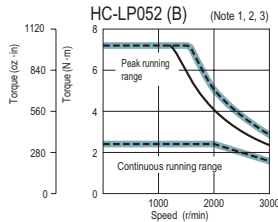

Notes:
 1. —: For 3-phase 200VAC.
 2. - - -: For 1-phase 230VAC.
 3. —: For 1-phase 200VAC.
 This line is drawn only where it differs from the other two lines.

HC-RP Series 200V Servomotor Specifications

Servomotor Model HC-RP_		103(B)	153(B)	203(B)	353(B)	503(B)
Servo Amplifier Model MR-J3-_-_-		200A(-RJ070)/BS/T		350A(-RJ070)/BS/T	500A(-RJ070)/BS/T	
Power Facility Capacity (kVA) (*1)		1.7	2.5	3.5	5.5	7.5
Continuous Running Duty	Rated Output (kW)	1.0	1.5	2.0	3.5	5.0
	Rated Torque (N•m [oz•in])	3.18 (450)	4.78 (677)	6.37 (902)	11.1 (1570)	15.9 (2250)
Maximum Torque (N•m [oz•in])		7.95 (1130)	11.9 (1690)	15.9 (2250)	27.9 (3950)	39.7 (5620)
Rated Speed (r/min)		3000				
Maximum Speed (r/min)		4500				
Permissible Instantaneous Speed (r/min)		5175				
Power Rate At Continuous Rated Torque (kW/s)		67.4	120	176	150	211
Rated Current (A)		6.1	8.8	14	23	28
Maximum Current (A)		18	23	37	58	70
Regen Braking Frequency (times/min) (*2)		1090	860	710	174	125
Moment Of inertia J (x10 ⁻⁴ kg•m ²) [J (oz•in ²)]	Standard	1.50 (8.20)	1.90 (10.4)	2.30 (12.6)	8.30 (45.4)	12.0 (65.6)
	With Electromagnetic Brake	1.85 (10.1)	2.25 (12.3)	2.65 (14.5)	11.8 (64.5)	15.5 (84.7)
Recommended Load/Motor Inertia Moment Ratio		5 times the servomotor's inertia moment maximum (*3)				
Speed/Position Detector		18-bit encoder (Resolution per encoder/servomotor rotation: 262144p/rev)				
Attachments		Oil seal				
Insulation Class		Class F				
Structure		Totally enclosed non-ventilated (protection level: IP65) (*4)				
Environment	Ambient Temperature	0 to 40°C (32 to 104°F) (non-freezing), storage: -15 to 70°C (5 to 158°F) (non-freezing)				
	Ambient Humidity	80% RH maximum (non-condensing), storage: 90% RH maximum (non-condensing)				
	Atmosphere	Indoors (no direct sunlight); no corrosive gas, inflammable gas, oil mist or dust				
	Elevation/Vibration (*5)	1000m or less above sea level X, Y: 24.5m/s ²				
Mass kg (lb)	Standard	3.9 (8.6)	5.0 (11)	6.2 (14)	12 (27)	17 (38)
	With Electromagnetic Brake	6.0 (14)	7.0 (16)	8.3 (19)	15 (33)	21 (47)

Notes:

- The power facility capacity varies depending on the power supply's impedance.
- The regenerative braking frequency shows the permissible frequency for decelerating the motor without a load and the optional regeneration unit from the rated speed to a stop.
- Contact Mitsubishi if the load/motor of inertia moment ratio exceeds the value in the table
- The shaft-through portion is excluded.
- The vibration direction is shown in the right-side diagram. The numeric value indicates the maximum value of the component (commonly the bracket in the opposite direction of the motor shaft). Fretting of the bearing occurs easily when the motor stops, so maintain vibration to approximately one-half of the allowable value.

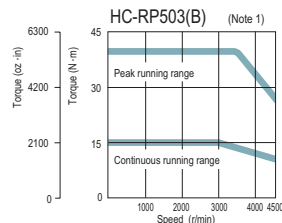
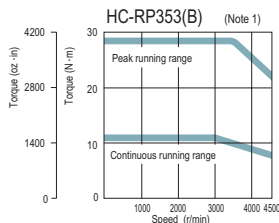
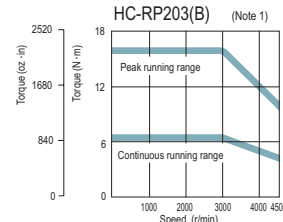
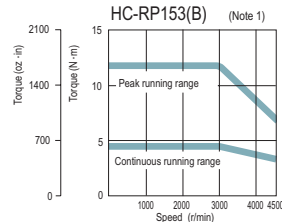
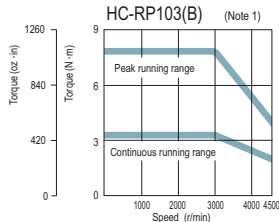

Notes:
1. For 3-phase 200VAC.

HC-UP Series 200V Servomotor Specifications

Servomotor Model HC-UP_		72(B)	152(B)	202(B)	352(B)	502(B)
Servo Amplifier Model MR-J3-_-		70A(-RJ070)/BS/T	200A(-RJ070)/BS/T	350A(-RJ070)/BS/T	500A(-RJ070)/BS/T	
Power Facility Capacity (kVA) (*1)		1.3	2.5	3.5	5.5	7.5
Continuous Running Duty	Rated Output (kW)	0.75	1.5	2.0	3.5	5.0
	Rated Torque (N•m [oz•in])	3.58 (507)	7.16 (1010)	9.55 (1350)	16.7 (2360)	23.9 (3380)
Maximum Torque (N•m [oz•in])		10.7 (1520)	21.6 (3060)	28.5 (4040)	50.1 (7090)	71.6 (10100)
Rated Speed (r/min)		2000				
Maximum Speed (r/min)		3000				2500
Permissible Instantaneous Speed (r/min)		3450				2875
Power Rate At Continuous Rated Torque (kW/s)		12.3	23.2	23.9	36.5	49.6
Rated Current (A)		5.4	9.7	14	23	28
Maximum Current (A)		16	29	42	69	84
Regen Braking Frequency (times/min) (*2)		53	124	68	44	31
Moment Of Inertia J (x10 ⁻⁴ kg•m ²) [J (oz•in ²)]	Standard	10.4 (56.9)	22.1 (121)	38.2 (209)	76.5 (418)	115 (629)
	With Electromagnetic Brake	12.5 (68.3)	24.2 (132)	46.8 (256)	85.1 (465)	124 (678)
Recommended Load / Motor Inertia Moment Ratio		15 times the servomotor's inertia moment maximum (*3)				
Speed / Position Detector		18-bit encoder (Resolution per encoder/servomotor rotation: 262144p/rev)				
Attachments		Oil seal				
Insulation Class		Class F				
Structure		Totally enclosed non-ventilated (protection level: IP65) (*4)				
Environment	Ambient Temperature	0 to 40°C (32 to 104°F) (non-freezing), storage: -15 to 70°C (5 to 158°F) (non-freezing)				
	Ambient Humidity	80% RH maximum (non-condensing), storage: 90% RH maximum (non-condensing)				
	Atmosphere	Indoors (no direct sunlight); no corrosive gas, inflammable gas, oil mist or dust				
	Elevation / Vibration (*5)	1000m or less above sea level X, Y: 24.5m/s ²	1000m or less above sea level X: 24.5m/s ² Y: 49m/s ²			
Mass kg (lb)	Standard	8.0 (18)	11 (25)	16 (36)	20 (44)	24 (53)
	With Electromagnetic Brake	10 (22)	13 (29)	22 (49)	26 (58)	30 (67)

Notes:

- The power facility capacity varies depending on the power supply's impedance.
- The regenerative braking frequency shows the permissible frequency for decelerating the motor without a load and the optional regeneration unit from the rated speed to a stop.
- Contact Mitsubishi if the load/motor of inertia moment ratio exceeds the value in the table.
- The shaft-through portion is excluded.
- The vibration direction is shown in the right-side diagram. The numeric value indicates the maximum value of the component (commonly the bracket in the opposite direction of the motor shaft). Fretting of the bearing occurs easily when the motor stops, so maintain vibration to approximately one-half of the allowable value.

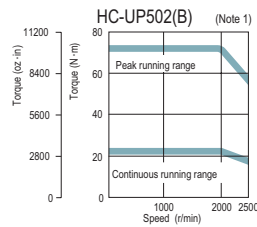
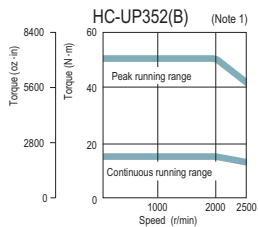
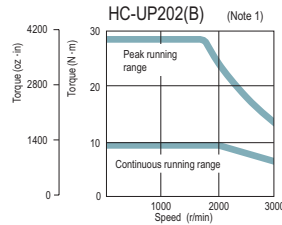
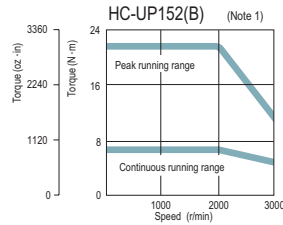
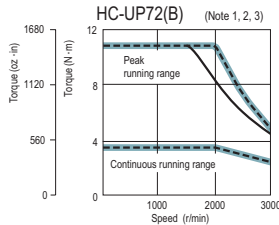

- Notes:
- For 3-phase 200VAC.
 - For 1-phase 230VAC.
 - For 1-phase 200VAC.
- This line is drawn only where it differs from the other two lines.

HF-JP Series 200V Servomotor Specifications

Servomotor Model HF-JP_	53(B)	73(B)	103(B)	153(B)	203(B)	353(B)	503(B)	11K1M(B)	15K1M(B)	
Servo Amplifier Model MR-J3-_-	60A/BS/T	70A/BS/T	100A/BS/T	200A/BS/T		350A/BS/T	500A/BS/T	11KA/BS/T-LR	15KA/BS/T-LR	
Power Supply Capacity (kVA) (*1)	1.0	1.3	1.7	2.5	3.5	5.5	7.5	16	22	
Continuous Running Duty	Rated Output (kW)	0.5	0.75	1.0	1.5	2.0	3.3 <3.5> (*7)	5.0	11	15
	Rated Torque (N•m [oz•in])	1.59 (225)	2.39 (338)	3.18 (450)	4.77 (675)	6.37 (902)	10.5 (1490) (*7) <11.1 (1570)>	15.9 (2250)	70 (9910)	95.5 (13500)
Maximum Torque (N•m [oz•in])	4.77 (675)	7.16 (1010)	9.55 (1350)	14.3 (2020)	19.1 (2700)	32.0 (4530)	47.7 (6750)	210 (29700)	286 (40500)	
Rated Speed (r/min)									1500	
Maximum Speed (r/min)									3000	
Permissible Instantaneous Speed (r/min)									3450	
Power Rate At Continuous Rated Torque (kW/s)	16.7	27.3	38.2	60.2	82.4	83.5	133	223 (204)	290 (271)	
Rated Current (A)	3.0	5.6	5.6	10.6	10.6	16.6 <17.6>	27	60	76	
Maximum Current (A)	9.0	17	17	32	32	51	81	200	246	
Regen Braking Frequency (times/min) (*2)	67	98	76	271	206	73	68	143	162	
Moment Of Inertia J (x10 ⁴ kg•m ² [J (oz•in ²)]	Standard	1.52 (8.31)	2.09 (11.4)	2.65 (14.5)	3.79 (20.7)	4.92 (26.9)	13.2 (72.2)	19.0 (104)	220 (1200)	315 (1720)
	With Electromagnetic Brake	2.02 (11.0)	2.59 (14.2)	3.15 (17.2)	4.29 (23.5)	5.42 (29.6)	15.4 (84.2)	21.2 (116)	240 (1310)	336 (1840)
Recommended Load/Motor Inertia Moment Ratio	Maximum of 10 times the servo motor's inertia moment (*3)									
Speed/Position Detector	18-bit encoder (Resolution per encoder/servo motor rotation: 262144 p/rev)									
Attachments	Oil seal									
Insulation Class	Class F									
Structure	Totally enclosed non-ventilated (IP code: IP67) (*4)									
Environment	Ambient Temperature	0 to 40°C (32 to 104°F) (non freezing), storage: -15 to 70°C (5 to 158°F) (non freezing)								
	Ambient Humidity	80% RH maximum (non condensing), storage: 90% RH maximum (non condensing)								
	Atmosphere	Indoors (no direct sunlight); no corrosive gas, inflammable gas, oil mist or dust								
	Elevation / Vibration (*5)	1000m or less above sea level X: 24.5m/s ² Y: 24.5m/s ²								
Mass kg (lb)	Standard	3.0 (6.7)	3.7 (8.2)	4.5 (10)	5.9 (13)	7.5 (17)	13 (29)	18 (40)	62 (140)	86 (190)
	With Electromagnetic Brake	4.4 (9.7)	5.1 (12)	5.9 (13)	7.3 (16)	8.9 (20)	15 (33)	20 (44)	74 (165)	97 (215)
Maximally Increased Torque (*8)	Compatible Servo Amplifier Model	MR-J3-100A/B/T-U100	MR-J3-200A/B/T-U101	MR-J3-200A/B/T-U102	MR-J3-350A/B/T-U103	MR-J3-350A/B/T-U104	MR-J3-500A/B/T-U105	MR-J3-700A/B/T-U106	-	-
	Maximum Torque (N•m [oz•in])	6.37 (902)	9.55 (1350)	12.7 (1800)	19.1 (2700)	25.5 (3610)	44.6 (6320)	63.7 (9020)	-	-
	Maximum Current (A)	12	23	23	43	43	71	108	-	-

Notes:

- The power supply capacity varies depending on the power supply's impedance.
- The regenerative braking frequency shows the permissible frequency when the motor, without a load and the optional regeneration unit, decelerates from the rated speed to a stop.
- Contact Mitsubishi if the load to motor inertia moment ratio exceeds the value in the table.
- The shaft-through portion is excluded.
- The vibration direction is shown in the diagram to the right. The numeric value indicates the maximum value of the component (commonly the bracket in the opposite direction of the motor shaft). Fretting of the bearing occurs easily when the motor stops, so maintain vibration to approximately one-half of the allowable value.



- In the environment where the servo motor is exposed to oil mist, oil and/or water, a standard specification servo motor may not be usable. Contact Mitsubishi for more details.
- Value indicated in < > is when connected to servo amplifier MR-J3-500A/B/T-U105.
- Use servo amplifier MR-J3_A/B/T-U_ for maximally increased torque.

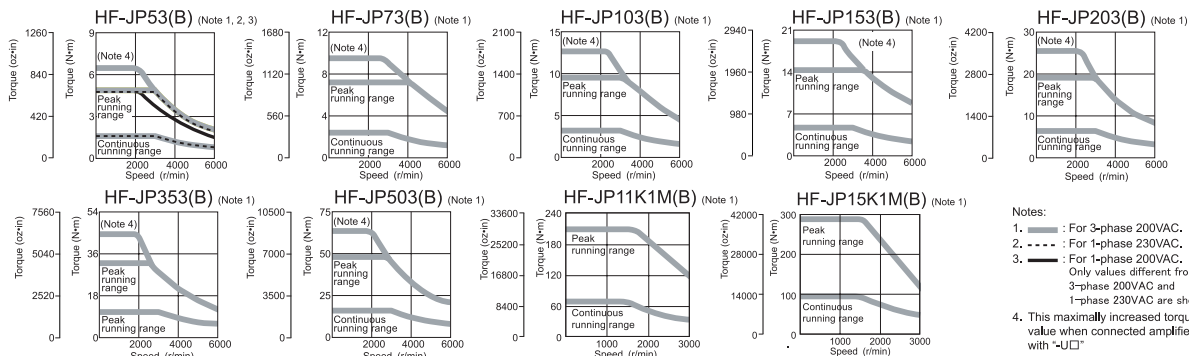

HF-JP Series 400V Servomotor Specifications

Servomotor Model HF-JP_		534(B)	734(B)	1034(B)	1534(B)	2034(B)	3534(B)	5034(B)	11K1M4(B)	15K1M4(B)			
Servo Amplifier Model MR-J3- _ _		60A4/BS4/T4		100A4/BS4/T4		200A4/BS4/4T		350A4/BS4/T4		500A4/BS4/T4		11KA4/BS4/T4-LR	15KA4/BS4/T4-LR
Power Supply Capacity (kVA) (*1)		1.0	1.3	1.7	2.5	3.5	5.5	7.5	16	22			
Continuous Running Duty	Rated Output (kW)	0.5	0.75	1.0	1.5	2.0	3.3 <3.5>	5.0	11	15			
	Rated Torque (N•m [oz•in])	1.59 (225)	2.39 (338)	3.18 (450)	4.77 (675)	6.37 (902)	10.5 (1490) <11.1 (1570)>	15.9 (2250)	70 (9910)	95.5 (13500)			
Maximum Torque (N•m [oz•in])		4.77 (675)	7.16 (1010)	9.55 (1350)	14.3 (2020)	19.1 (2700)	32.0 (4530)	47.7 (6750)	210 (29700)	286 (40500)			
Rated Speed (r/min)		3000								1500			
Maximum Speed (r/min)		6000								3000			
Permissible Instantaneous Speed (r/min)		6900								3450			
Power Rate At Continuous Rated Torque (kW/s)		16.7	27.3	38.2	60.2	82.4	83.5	133	223 (204)	290 (271)			
Rated Current (A)		1.5	2.8	2.8	5.4	5.4	8.3 <8.8>	14	32	38			
Maximum Current (A)		4.5	8.4	8.4	17	17	26	41	100	123			
Regen Braking Frequency (times/min) (*2)		99	72	56	265	203	75	68	143	162			
Moment Of Inertia J (x10 ⁻⁴ kg•m ²) [J (oz•in ²)]	Standard	1.52 (8.31)	2.09 (11.4)	2.65 (14.5)	3.79 (20.7)	4.92 (26.9)	13.2 (72.2)	19.0 (104)	220 (1200)	315 (1720)			
	With Electromagnetic Brake	2.02 (11.0)	2.59 (14.2)	3.15 (17.2)	4.29 (23.5)	5.42 (29.6)	15.4 (84.2)	21.2 (116)	240 (1310)	336 (1840)			
Recommended Load/Motor Inertia Moment Ratio		Maximum of 10 times the servo motor's inertia moment (*3)											
Speed/Position Detector		18-bit encoder (Resolution per encoder/servo motor rotation: 262144 p/rev)											
Attachments		Oil seal											
Insulation Class		Class F											
Structure		Totally enclosed non-ventilated (IP code: IP67) (*4)											
Environment (*6)	Ambient Temperature	0 to 40°C (32 to 104°F) (non freezing), storage: -15 to 70°C (5 to 158°F) (non freezing)											
	Ambient Humidity	80% RH maximum (non condensing), storage: 90% RH maximum (non condensing)											
	Atmosphere	Indoors (no direct sunlight); no corrosive gas, inflammable gas, oil mist or dust											
	Elevation / Vibration (*5)	1000m or less above sea level											
Mass kg (lb)	Standard	3.0 (6.7)	3.7 (8.2)	4.5 (10)	5.9 (13)	7.5 (17)	13 (29)	18 (40)	62 (140)	86 (190)			
	With Electromagnetic Brake	4.4 (9.7)	5.1 (12)	5.9 (13)	7.3 (16)	8.9 (20)	15 (33)	20 (44)	74 (165)	97 (215)			
Maximally Increased Torque (*8)	Compatible Servo Amplifier Model	MR-J3-100A4/B4/T4-U110	MR-J3-200A4/B4/T4-U111	MR-J3-200A4/B4/T4-U112	MR-J3-350A4/B4/T4-U113	MR-J3-350A4/B4/T4-U114	MR-J3-500A4/B4/T4-U115	MR-J3-700A4/B4/T4-U116	-	-			
	Maximum Torque (N•m [oz•in])	6.37 (902)	9.55 (1350)	12.7 (1800)	19.1 (2700)	25.5 (3610)	44.6 (6320)	63.7 (9020)	-	-			
	Maximum Current (A)	6	12	12	22	22	36	34	-	-			

Notes:

- The power supply capacity varies depending on the power supply's impedance.
- The regenerative braking frequency shows the permissible frequency when the motor, without a load and the optional regeneration unit, decelerates from the rated speed to a stop.
- Contact Mitsubishi if the load to motor inertia moment ratio exceeds the value in the table.
- The shaft-through portion is excluded.
- The vibration direction is shown in the diagram to the right. The numeric value indicates the maximum value of the component (commonly the bracket in the opposite direction of the motor shaft). Fretting of the bearing occurs easily when the motor stops, so maintain vibration to approximately one-half of the allowable value.



- In the environment where the servo motor is exposed to oil mist, oil and/or water, a standard specification servo motor may not be usable. Contact Mitsubishi for more details.
- Value indicated in <> is when connected to servo amplifier MR-J3-500A/BS/T-U105.
- Use servo amplifier MR-J3- _A/BS/T- _ for maximally increased torque.

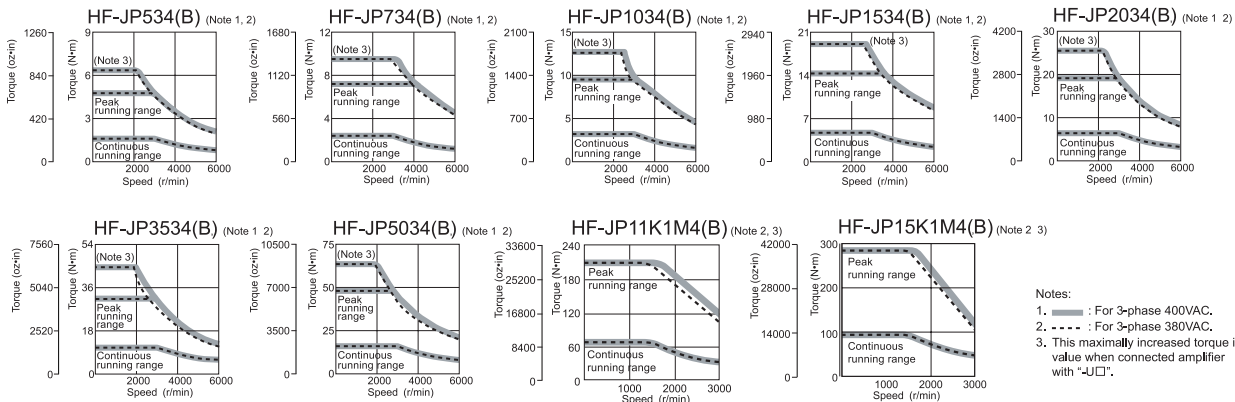

- Notes:**
- : For 3-phase 400VAC.
 - - - : For 3-phase 380VAC.
 - This maximally increased torque is value when connected amplifier with "U□".

HA-LP 1000r/min Series 200V Servomotor Specifications

Servomotor Model HA-LP_	601(B)	801(B)	12K1(B)	15K1	20K1	25K1	30K1	37K1	
Servo Amplifier Model MR-J3-_-	700A(-RJ070)/BS/T	11KA(-RJ070)/BS/T		15KA(-RJ070)/BS/T	22KA(-RJ070)/BS/T		DU30KA(-RJ070)/BS	DU37KA(-RJ070)/BS	
Power Facility Capacity (kVA) (*1)	8.6	12	18	22	30	38	48	59	
Continuous Running Duty	Rated Output (kW)	6.0	8.0	12	15	20	25	30	37
	Rated Torque (N•m [oz•in])	57.3 (8110)	76.4 (10800)	115 (16300)	143 (20200)	191 (2700)	239 (33800)	286 (40500)	353 (50000)
Maximum Torque (N•m [oz•in])	172 (24400)	229 (32400)	344 (48700)	415 (58800)	477 (67500)	597 (84500)	716 (101000)	883 (125000)	
Rated Speed (r/min)	1000								
Maximum Speed (r/min)	1200								
Permissible Instantaneous Speed (r/min)	1380								
Power Rate At Continuous Rated Torque (kW/s)	313	265	445	373	561	528	626	668	
Rated Current (A)	34	42	61	83	118	118	154	188	
Maximum Current (A)	102	126	183	249	295	295	385	470	
Regen Braking Frequency (times/min) (*2)	158	354 (*6)	264 (*6)	230 (*6)	195 (*6)	117 (*6)	-	-	
Moment Of Inertia J (x10 ⁻⁴ kg•m ²) [J (oz•in ²)]	Standard	105 (574)	220 (1200)	295 (1610)	550 (3010)	650 (3550)	1080 (5900)	1310 (7160)	1870 (10200)
	With Electromagnetic Brake	113 (618)	293 (1600)	369 (2020)	-	-	-	-	-
Recommended Load / Motor Inertia Moment Ratio	10 times the servomotor's inertia moment maximum (*3)								
Speed / Position Detector	18-bit encoder (Resolution per encoder/servomotor rotation: 262144p/rev)								
Attachments	Oil seal								
Insulation Class	Class F								
Structure	Totally enclosed ventilated (protection level: IP44) (*4)								
Environment	Ambient Temperature	0 to 40°C (32 to 104°F) (non-freezing), storage: -15 to 70°C (5 to 158°F) (non-freezing)							
	Ambient Humidity	80% RH maximum (non-condensing), storage: 90% RH maximum (non-condensing)							
	Atmosphere	Indoors (no direct sunlight); no corrosive gas, inflammable gas, oil mist or dust							
	Elevation/ Vibration (*5)	1000m or less above sea level X: 11.7m/s ² Y: 29.4m/s ²			1000m or less above sea level X: 9.8m/s ² Y: 9.8m/s ²				
Mass kg (lb)	Standard	55 (125)	95 (210)	115 (255)	160 (355)	180 (400)	230 (510)	250 (555)	335 (740)
	With Electromagnetic Brake	70 (155)	130 (290)	150 (335)	-	-	-	-	-
Cooling Fan Power	Voltage, Frequency	1-phase 200 to 220VAC/50Hz 1-phase 200 to 230VAC/60Hz 3-phase 200 to 230VAC 50/60Hz							
	Input (W)	42 (50Hz)/ 54 (60Hz)	62 (50Hz) / 76 (60Hz)		65 (50Hz) / 85 (60Hz)		120 (50Hz) / 175 (60Hz)		
Cooling Fan Rated Current (A)	0.21(50Hz)/ 0.25 (60Hz)	0.18 (50Hz) / 0.17 (60Hz)		0.20 (50Hz) / 0.22 (60Hz)		0.65 (50Hz) / 0.80 (60Hz)			

Notes:

- The power facility capacity varies depending on the power supply's impedance.
- The regenerative braking frequency shows the permissible frequency for decelerating the motor without a load and the optional regeneration unit from the rated speed to a stop.
- Contact Mitsubishi if the load/motor of inertia moment ratio exceeds the value in the table.
- The shaft-through portion is excluded.
- The vibration direction is shown in the right-side diagram. The numeric value indicates the maximum value of the component (commonly the bracket in the opposite direction of the motor shaft). Fretting of the bearing occurs easily when the motor stops, so maintain vibration to approximately one-half of the allowable value.



- This applies when the GRZG400-Ω regeneration resistors are used as a standard accessory and parameter PA02 is changed with cooling fan (1.0m³/min, the _92x2 unit) installed.

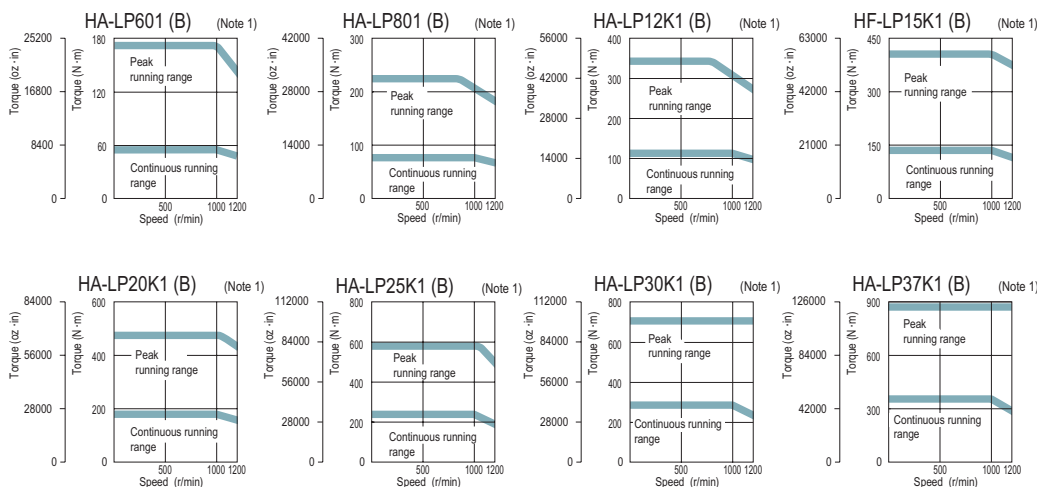

HA-LP 1000r/min Series 400V Servomotor Specifications

Servomotor Model HA-LP_	6014(B)	8014(B)	12K14(B)	15K14	20K14	25K14	30K14	37K14	
Servo Amplifier Model MR-J3- _ _	700A4(-RJ070)/BS4/T4	11KA4(-RJ070)/BS4/T4		15KA4(-RJ070)/BS4(-RJ006)/T4	22KA4(-RJ070)/BS4/T4	DU30KA4(-RJ070)/BS4		DU37KA4(-RJ070)/BS4	
Power Facility Capacity (kVA) (*1)	8.6	12	18	22	30	38	48	59	
Continuous Running Duty	Rated Output (kW)	6.0	8.0	12	15	20	25	30	37
	Rated Torque (N•m [oz•in])	57.3 (8110)	76.4 (10800)	115 (16300)	143 (20200)	191 (27000)	239 (33800)	286 (40500)	353 (50000)
Maximum Torque (N•m [oz•in])	172 (24400)	229 (32400)	344 (48700)	415 (58800)	477 (67500)	597 (84500)	716 (101000)	883 (125000)	
Rated Speed (r/min)	1000								
Maximum Speed (r/min)	1200								
Permissible Instantaneous Speed (r/min)	1380								
Power Rate At Continuous Rated Torque (kW/s)	313	265	445	373	561	528	626	668	
Rated Current (A)	17	20	30	40	55	70	77	95	
Maximum Current (A)	51	60	90	120	138	175	193	238	
Regen Braking Frequency (times/min) (*2)	169	354 (*6)	264 (*6)	230 (*6)	195 (*6)	-	-	-	
Moment Of Inertia J (x10 ⁻⁴ kg•m ²) [J (oz•in ²)]	Standard	105 (574)	220 (1200)	295 (1610)	550 (3010)	650 (3550)	1080 (5900)	1310 (7160)	1870 (10200)
	With Electromagnetic Brake	113 (617.7)	293 (1601.7)	369 (2017.2)	-	-	-	-	-
Recommended Load/Motor Inertia Moment Ratio	10 times the servomotor's inertia moment maximum (*3)								
Speed/Position Detector	18-bit encoder (Resolution per encoder/servomotor rotation: 262144p/rev)								
Attachments	Oil seal								
Insulation Class	Class F								
Structure	Totally enclosed ventilated (protection level: IP44) (*4)								
Environment	Ambient Temperature	0 to 40°C (32 to 104°F) (non-freezing), storage: -15 to 70°C (5 to 158°F) (non-freezing)							
	Ambient Humidity	80% RH maximum (non-condensing), storage: 90% RH maximum (non-condensing)							
	Atmosphere	Indoors (no direct sunlight); no corrosive gas, inflammable gas, oil mist or dust							
	Elevation / Vibration (*5)	1000m or less above sea level X: 11.7m/s ² Y: 29.4m/s ²		1000m or less above sea level X: 9.8m/s ² Y: 9.8m/s ²					
Mass kg (lb)	Standard	55 (125)	95 (210)	115 (255)	160 (355)	180 (400)	230 (510)	250 (555)	335 (740)
	With Electromagnetic Brake	70 (155)	130 (290)	150 (335)	-	-	-	-	-
Cooling Fan Power	Voltage, Frequency	1-phase 200 to 220VAC/50Hz 1-phase 200 to 230VAC/60Hz	3-phase 380 to 440VAC 50Hz 3-phase 380 to 480 VAC 60Hz		3-phase 380 to 460VAC 50Hz; 3-phase 380 to 480VAC 60Hz				
	Input (W)	42 (50Hz)/ 54 (60Hz)	62 (50Hz)/76 (60Hz)		65 (50Hz)/85 (60Hz)		110 (50Hz)/150 (60Hz)		
Cooling Fan Rated Current (A)	0.21 (50Hz)/ 0.25 (60Hz)	0.14 (50Hz)/0.11 (60Hz)		0.12 (50Hz)/0.14 (60Hz)		0.20 (50Hz)/0.22 (60Hz)			

Notes:

- The power facility capacity varies depending on the power supply's impedance.
- The regenerative braking frequency shows the permissible frequency for decelerating the motor without a load and the optional regeneration unit from the rated speed to a stop.
- Contact Mitsubishi if the load/motor of inertia moment ratio exceeds the value in the table.
- The shaft-through portion is excluded.
- The vibration direction is shown in the right-side diagram. The numeric value indicates the maximum value of the component (commonly the bracket in the opposite direction of the motor shaft). Fretting of the bearing occurs easily when the motor stops, so maintain vibration to approximately one-half of the allowable value.



- This applies when the GRZG400- _ Ω regeneration resistors are used as a standard accessory and parameter PA02 is changed with cooling fan (1.0m³/min, the _92 x 2 unit) installed.

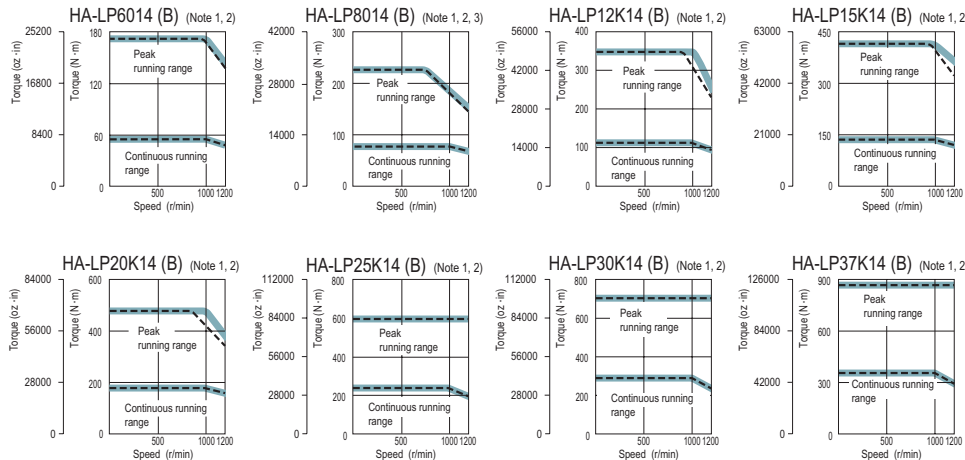

- Notes:
 1. ———— : For 3-phase 400VAC.
 2. - - - - : For 3-phase 380VAC.
 3. The torque characteristics are anticipated values.

HA-LP 1500r/min Series 200V Servomotor Specifications

Servomotor Model HA-LP_		701M(B)	11K1M(B)	15K1M(B)	22K1M	30K1M	37K1M
Servo Amplifier Model MR-J3-_-		700A(-RJ070)/BS/T	11KA(-RJ070)/BS/T	15KA(-RJ070)/BS/T	22KA(-RJ070)/BS/T	DU30KA(-RJ070)/BS	DU37KA(-RJ070)/BS
Power Facility Capacity (kVA) (*1)		10	16	22	33	48	59
Continuous Running Duty	Rated Output (kW)	7.0	11	15	22	30	37
	Rated Torque (N•m [oz•in])	44.6 (6320)	70.0 (9910)	95.5 (13500)	140 (19800)	191 (27000)	236 (33400)
Maximum Torque (N•m [oz•in])		134 (19000)	210 (29700)	286 (40500)	350 (49600)	477 (67500)	589 (83400)
Rated Speed (r/min)		1500					
Maximum Speed (r/min)		2000					
Permissible Instantaneous Speed (r/min)		2300					
Power Rate at Continuous Rated Torque (kW/s)		189	223	309	357	561	514
Rated Current (A)		37	65	87	126	174	202
Maximum Current (A)		111	195	261	315	435	505
Regen Braking Frequency (times/min) (*2)		70	158 (*6)	191 (*6)	102 (*6)	-	-
Moment Of inertia J (x10 ⁻⁴ kg•m ²) [J (oz•in ²)]	Standard	105 (574)	220 (1200)	295 (1610)	550 (3010)	650 (3550)	1080 (5900)
	With Electromagnetic Brake	113 (618)	293 (1600)	369 (2020)	-	-	-
Recommended Load / Motor Inertia Moment Ratio		10 times the servomotor's inertia moment maximum (*3)					
Speed / Position Detector		18-bit encoder (Resolution per encoder/servomotor rotation: 262144p/rev)					
Attachments		Oil seal					
Insulation Class		Class F					
Structure		Totally enclosed ventilated (protection level: IP44) (*4)					
Environment	Ambient Temperature	0 to 40°C (32 to 104°F) (non-freezing), storage: -15 to 70°C (5 to 158°F) (non-freezing)					
	Ambient Humidity	80% RH maximum (non-condensing), storage: 90% RH maximum (non-condensing)					
	Atmosphere	Indoors (no direct sunlight); no corrosive gas, inflammable gas, oil mist or dust					
	Elevation / Vibration (*5)	1000m or less above sea level X: 11.7m/s ² Y: 29.4m/s ²			1000m or less above sea level X: 9.8m/s ² Y: 9.8m/s ²		
Mass kg (lb)	Standard	55 (125)	95 (210)	115 (255)	160 (355)	180 (400)	230 (510)
	With Electromagnetic Brake	70 (155)	130 (290)	150 (335)	-	-	-
Cooling Fan Power	Voltage, Frequency	1-phase 200 to 220VAC / 50 Hz 1-phase 200 to 230VAC / 60Hz		3-phase 200 to 230VAC 50/60Hz			
	Input (W)	42 (50Hz) / 54 (60Hz)	62 (50Hz) / 76 (60Hz)		65 (50Hz) / 85 (60Hz)		120 (50Hz) / 175 (60Hz)
Cooling Fan Rated Current (A)		0.21 (50Hz) / 0.25 (60Hz)	0.18 (50Hz) / 0.17 (60Hz)		0.20 (50Hz) / 0.22 (60Hz)		0.65 (50Hz) / 0.80 (60Hz)

Notes:

- The power facility capacity varies depending on the power supply's impedance.
- The regenerative braking frequency shows the permissible frequency for decelerating the motor without a load and the optional regeneration unit from the rated speed to a stop.
- Contact Mitsubishi if the load/motor of inertia moment ratio exceeds the value in the table.
- The shaft-through portion is excluded.
- The vibration direction is shown in the right-side diagram. The numeric value indicates the maximum value of the component (commonly the bracket in the opposite direction of the motor shaft). Fretting of the bearing occurs easily when the motor stops, so maintain vibration to approximately one-half of the allowable value.



- This applies when the GRZG400-Ω regeneration resistors are used as a standard accessory and parameter PA02 is changed with cooling fan (1.0m³/min, the _92 x 2 unit) installed.

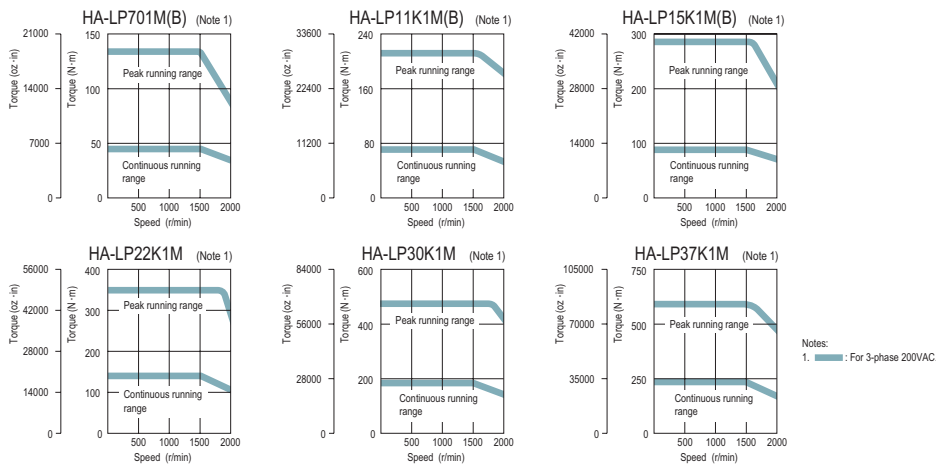

HA-LP 1500r/min Series 400V Servomotor Specifications

Servomotor Model HA-LP_	701M4(B)	11K1M4(B)	15K1M4(B)	22K1M4	30K1M4	37K1M4	45K1M4	50K1M4	
Servo Amplifier Model MR-J3- _ _	700A4(-RJ070)/BS4/T4	11KA4(-RJ070)/BS4/T4	15KA4(-RJ070)/BS4/T4	22KA4(-RJ070)/BS4/T4	DU30KA4 (-RJ070)/BS4	DU37KA4 (-RJ070)/BS4	DU45KA4 (-RJ070)/BS4	DU55KA4 (-RJ070)/BS4	
Power Facility Capacity (kVA) (*1)	10	16	22	33	48	59	71	80	
Continuous Running Duty	Rated Output (kW)	7.0	11	15	22	30	37	50	
	Rated Torque (N•m [oz•in])	44.6 (6320)	70.0 (9910)	95.5 (13500)	140 (19800)	191 (27000)	236 (33400)	286 (40500)	318 (45000)
Maximum Torque (N•m [oz•in])	134 (19000)	210 (29700)	286 (40500)	350 (49600)	477 (67500)	589 (83400)	716 (101000)	796 (113000)	
Rated Speed (r/min)	1500								
Maximum Speed (r/min)	2000								
Permissible Instantaneous Speed (r/min)	2300								
Power Rate At Continuous Rated Torque (kW/s)	189	223	309	357	561	514	626	542	
Rated Current (A)	18	31	41	63	87	101	128	143	
Maximum Current (A)	54	93	123	158	218	253	320	358	
Regen Braking Frequency (times/min) (*2)	75	158 (*6)	191 (*6)	102 (*6)	-	-	-	-	
Moment Of Inertia J (x10 ⁻⁴ kg•m ²) [J (oz•in ²)]	Standard	105 (574)	220 (1200)	295 (1610)	550 (3010)	650 (3550)	1080 (5900)	1310 (7100)	1870 (10200)
	With Electromagnetic Brake	113 (618)	293 (1600)	369 (2020)	-	-	-	-	-
Recommended Load / Motor Inertia Moment Ratio	10 times the servomotor's inertia moment maximum (*3)								
Speed / Position Detector	18-bit encoder (Resolution per encoder/servomotor rotation: 262144p/rev)								
Attachments	Oil seal								
Insulation class	Class F								
Structure	Totally enclosed ventilated (protection level: IP44) (*4)								
Environment	Ambient Temperature	0 to 40°C (32 to 104°F) (non-freezing), storage: -15 to 70°C (5 to 158°F) (non-freezing)							
	Ambient Humidity	80% RH maximum (non-condensing), storage: 90% RH maximum (non-condensing)							
	Atmosphere	Indoors (no direct sunlight); no corrosive gas, inflammable gas, oil mist or dust							
Elevation / Vibration (*5)	1000m or less above sea level X: 11.7m/s ² Y: 29.4m/s ²			1000m or less above sea level X: 9.8m/s ² Y: 9.8m/s ²					
	Standard	55 (125)	95 (210)	115 (255)	160 (355)	180 (400)	230 (510)	250 (555)	335 (740)
Mass kg (lb)	With Electromagnetic Brake	70 (154.2)	130 (290)	150 (335)	-	-	-	-	
	Standard	55 (125)	95 (210)	115 (255)	160 (355)	180 (400)	230 (510)	250 (555)	335 (740)
Cooling Fan Power	Voltage, Frequency	1-phase 200 to 220VAC/50Hz 1-phase 200 to 230VAC/60Hz	3-phase 380 to 440VAC 50Hz 3-phase 380 to 480VAC 60Hz		3-phase 380 to 460VAC 50Hz 3-phase 380 to 480VAC 60Hz				
	Input (W)	42 (50Hz)/ 54 (60Hz)	62 (50Hz) / 76 (60Hz)		65 (50Hz) / 85 (60Hz)		110 (50Hz) / 150 (60Hz)		
Cooling Fan Rated Current (A)	0.21 (50Hz)/ 0.25 (60Hz)	0.14 (50Hz) / 0.11 (60Hz)		0.12 (50Hz) / 0.14 (60Hz)		0.20 (50Hz) / 0.22 (60Hz)			

Notes:

- The power facility capacity varies depending on the power supply's impedance.
- The regenerative braking frequency shows the permissible frequency for decelerating the motor without a load and the optional regeneration unit from the rated speed to a stop.
- Contact Mitsubishi if the load/motor of inertia moment ratio exceeds the value in the table.
- The shaft-through portion is excluded.
- The vibration direction is shown in the right-side diagram. The numeric value indicates the maximum value of the component (commonly the bracket in the opposite direction of the motor shaft). Fretting of the bearing occurs easily when the motor stops, so maintain vibration to approximately one-half of the allowable value.



- This applies when the GRZG400-Ω regeneration resistors are used as a standard accessory and parameter PA02 is changed with cooling fan (1.0m³/min, the _92 x 2 unit) installed.

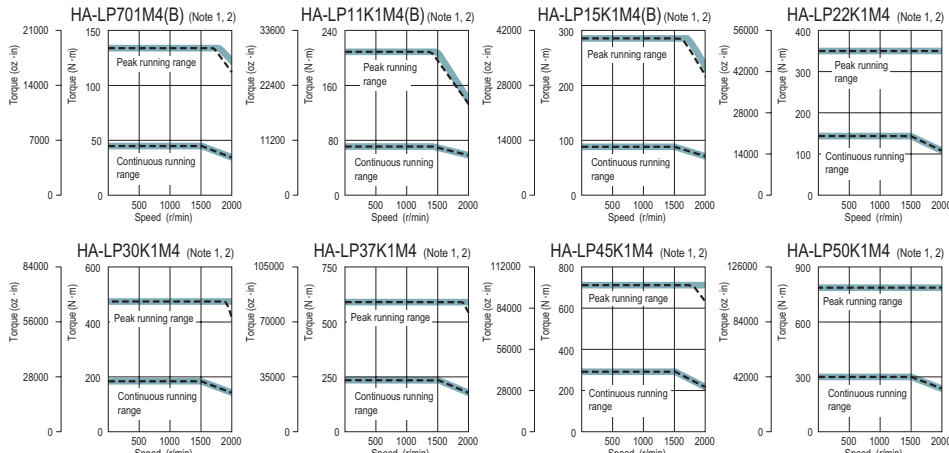

Notes:
 1. — : For 3-phase 400VAC.
 2. - - - : For 3-phase 380VAC.

HA-LP 2000r/min Series 200V Servomotor Specifications

Servomotor Model HA-LP_		502	702	11K2(B)	15K2(B)	22K2(B)	30K2	37K2	
Servo Amplifier Model MR-J3-_-_-		500A(-RJ070)/BS/T	700A(-RJ070)/BS/T	11KA(-RJ070)/BS/T	15KA(-RJ070)/BS/T	22KA(-RJ070)/BS/T	DU30KA(-RJ070)/BS	DU37KA(-RJ070)/BS	
Power Facility Capacity (kVA) (*1)		7.5	10.0	16	22	33	48	59	
Continuous Running Duty	Rated Output (kW)	5.0	7.0	11	15	22	30	37	
	Rated Torque (N•m [oz•in])	23.9 (3380)	33.4 (4730)	52.5 (7430)	71.6 (10100)	105 (14900)	143 (20200)	177 (25100)	
Maximum Torque (N•m [oz•in])		71.6 (10100)	100 (14200)	158 (22400)	215 (30400)	263 (37200)	358 (50700)	442 (62600)	
Rated Speed (r/min)		2000							
Maximum Speed (r/min)		2000							
Permissible Instantaneous Speed (r/min)		2300							
Power Rate At Continuous Rated Torque (kW/s)		77.2	118	263	233	374	373	480	
Rated Current (A)		25	34	63	77	112	166	204	
Maximum Current (A)		75	102	189	231	280	415	510	
Regen Braking Frequency (times/min) (*2)		50	50	186 (*6)	144 (*6)	107 (*6)	-	-	
Moment Of Inertia J (x10 ⁻⁴ kg•m ²) [J (oz•in ²)]	Standard	74.0 (405)	94.2 (515)	105 (574)	220 (1200)	295 (1610)	550 (3010)	650 (3550)	
	With Electromagnetic Brake	-	-	113 (618)	293 (1600)	369 (2020)	-	-	
Recommended Load/Motor Inertia Moment Ratio		10 times the servomotor's inertia moment maximum (*3)							
Speed/Position Detector		18-bit encoder (Resolution per encoder/servomotor rotation: 262144p/rev)							
Attachments		Oil seal							
Insulation Class		Class F							
Structure		Totally enclosed non-ventilated (protection level: IP65) (*4)			Totally enclosed ventilated (protection level: IP44) (*4)				
Environment	Ambient Temperature	0 to 40°C (32 to 104°F) (non-freezing), storage: -15 to 70°C (5 to 158°F) (non-freezing)							
	Ambient Humidity	80% RH maximum (non-condensing), storage: 90% RH maximum (non-condensing)							
	Atmosphere	Indoors (no direct sunlight); no corrosive gas, inflammable gas, oil mist or dust							
	Elevation / Vibration	1000m or less above sea level X: 11.7m/s ² Y: 29.4m/s ²					1000m or less above sea level X: 9.8m/s ² Y: 9.8m/s ²		
Mass kg (lb)	Standard	28 (62)	35 (78)	55 (125)	95 (210)	115 (255)	160 (355)	180 (400)	
	With Electromagnetic Brake	-	-	70 (155)	130 (290)	150 (335)	-	-	
Cooling Fan Power	Voltage, Frequency (*5)	-	-	1-phase 200 to 220 VAC/50Hz 1-phase 200 to 230 VAC/60Hz		3-phase 200 to 230VAC 50/60Hz			
	Input (W)	-	-	42 (50Hz) / 54 (60Hz)		62 (50Hz) / 76 (60Hz)		65 (50Hz) / 85 (60Hz)	
Cooling Fan Rated Current (A)		-	-	0.21 (50Hz)/ 0.25 (60Hz)		0.18 (50Hz) / 0.17 (60Hz)		0.20 (50Hz) / 0.22 (60Hz)	

Notes:

- The power facility capacity varies depending on the power supply's impedance.
- The regenerative braking frequency shows the permissible frequency for decelerating the motor without a load and the optional regeneration unit from the rated speed to a stop.
- Contact Mitsubishi if the load/motor of inertia moment ratio exceeds the value in the table.
- The shaft-through portion is excluded.
- The vibration direction is shown in the right-side diagram. The numeric value indicates the maximum value of the component (commonly the bracket in the opposite direction of the motor shaft). Fretting of the bearing occurs easily when the motor stops, so maintain vibration to approximately one-half of the allowable value.



- This applies when the GRZG400-Ω regeneration resistors are used as a standard accessory and parameter PA02 is changed with cooling fan (1.0m³/min, the _92 x 2 unit) installed.

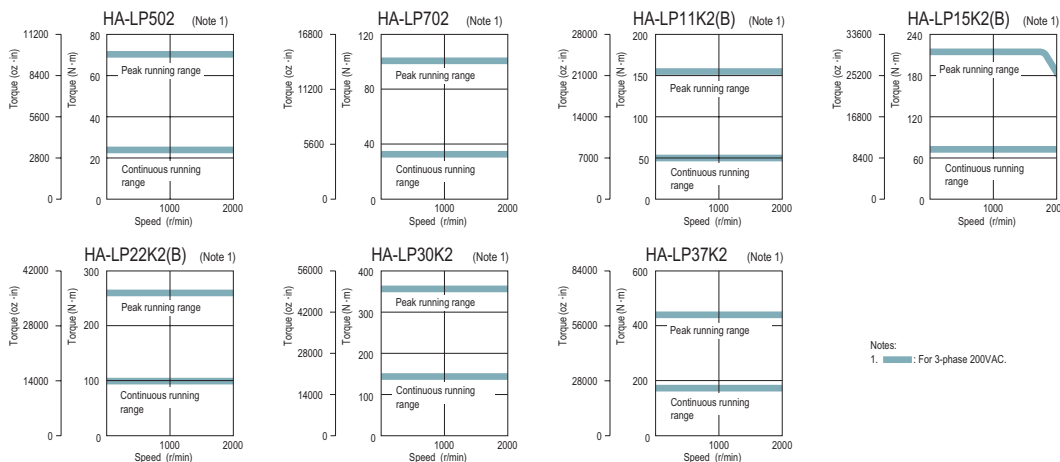

HA-LP 2000r/min Series 400V Servomotor Specifications

Servomotor Model HA-LP_	11K24(B)	15K24(B)	22K24(B)	30K24	37K24	45K24	55K24	
Servo Amplifier Model MR-J3-_-_-	11KA4(-RJ070)/BS4/T4	15KA4(-RJ070)/BS4/T4	22KA4(-RJ070)/BS4/T4	DU30KA4/BS4	DU37KA4/BS4	DU45KA4/BS4	DU55KA4/BS4	
Power Facility Capacity (kVA) (*1)	16	22	33	48	59	71	87	
Continuous Running Duty	Rated Output (kW)	11	15	22	30	37	55	
	Rated Torque (N·m [oz·in])	52.5 (7430)	71.6 (10100)	105 (14900)	143 (20200)	177 (25100)	215 (30400)	263 (37200)
Maximum Torque (N·m [oz·in])	158 (22400)	215 (30400)	263 (37200)	358 (50700)	442 (62600)	537 (76000)	657 (93000)	
Rated Speed (r/min)	2000							
Maximum Speed (r/min)	2000							
Permissible Instantaneous Speed (r/min)	2300							
Power Rate At Continuous Rated Torque (kW/s)	263	233	374	373	480	427	526	
Rated Current (A)	32	40	57	83	102	131	143	
Maximum Current (A)	96	120	143	208	255	328	358	
Regen. Braking Frequency (times/min) (*2)	186 (*6)	144 (*6)	107 (*6)	-	-	-	-	
Moment of Inertia J (x10 ⁻⁴ kg·m ²) [J (oz·in ²)]	Standard	105 (574)	220 (1200)	295 (1610)	550 (3010)	650 (3550)	1080 (5900)	1310 (7160)
	With Electromagnetic Brake	113 (618)	293 (1600)	369 (2020)	-	-	-	-
Recommended Load / Motor Inertia Moment Ratio	10 times the servomotor's inertia moment maximum (*3)							
Speed / Position Detector	18-bit encoder (Resolution per encoder/servomotor rotation: 262144p/rev)							
Attachments	Oil seal							
Insulation Class	Class F							
Structure	Totally enclosed ventilated (protection level: IP44) (*4)							
Environment	Ambient Temperature	0 to 40°C (32 to 104°F) (non-freezing), storage: -15 to 70°C (5 to 158°F) (non-freezing)						
	Ambient Humidity	80% RH maximum (non-condensing), storage: 90% RH maximum (non-condensing)						
	Atmosphere	Indoors (no direct sunlight); no corrosive gas, inflammable gas, oil mist or dust						
Elevation / Vibration (*5)	1000m or less above sea level X: 11.7m/s ² Y: 29.4m/s ²			1000m or less above sea level X: 9.8m/s ² Y: 9.8m/s ²				
	Standard	55 (125)	95 (210)	115 (255)	160 (355)	180 (400)	230 (510)	250 (555)
Mass kg (lb)	With Electromagnetic Brake	70 (155)	130 (290)	150 (335)	-	-	-	-
	Voltage, Frequency	1-phase 200 to 220 VAC / 50Hz 1-phase 200 to 230 VAC / 60Hz		3-phase 380 to 440VAC 50Hz 3-phase 380 to 480VAC 60Hz		3-phase 380 to 460VAC 50Hz 3-phase 380 to 480VAC 60Hz		
Cooling Fan Power	Input (W)	42 (50Hz) / 54 (60Hz)		62 (50Hz) / 76 (60Hz)		65 (50Hz) / 85 (60Hz)		110 (50Hz) / 150 (60Hz)
	Cooling Fan Rated Current (A)	0.21 (50Hz) / 0.25 (60Hz)		0.14 (50Hz) / 0.11 (60Hz)		0.12 (50Hz) / 0.14 (60Hz)		0.20 (50Hz) / 0.22 (60Hz)

Notes:

- The power facility capacity varies depending on the power supply's impedance.
- The regenerative braking frequency shows the permissible frequency for decelerating the motor without a load and the optional regeneration unit from the rated speed to a stop.
- Contact Mitsubishi if the load/motor of inertia moment ratio exceeds the value in the table.
- The shaft-through portion is excluded.
- The vibration direction is shown in the right-side diagram. The numeric value indicates the maximum value of the component (commonly the bracket in the opposite direction of the motor shaft). Fretting of the bearing occurs easily when the motor stops, so maintain vibration to approximately one-half of the allowable value.



- This applies when the GRZG400-Ω regeneration resistors are used as a standard accessory and parameter PA02 is changed with cooling fan (1.0m³/min, the _92x2 unit) installed.

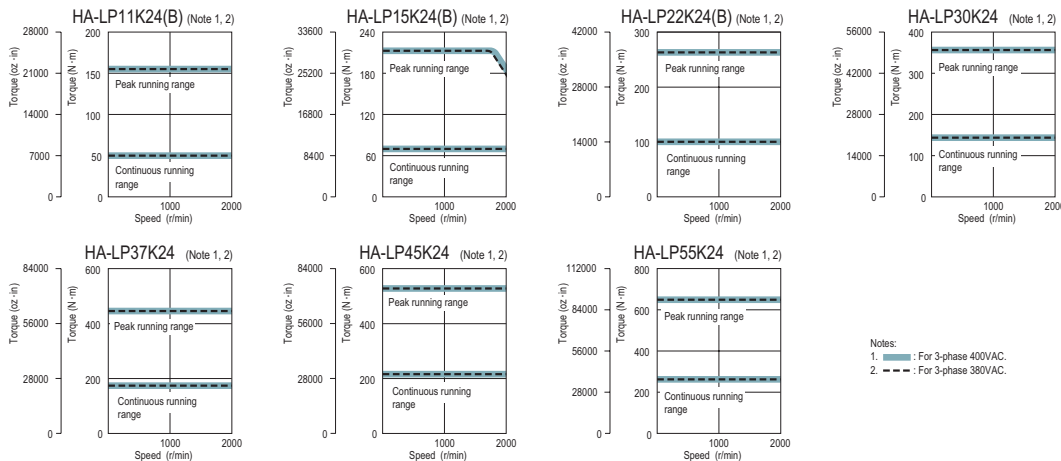

D Cables and Connectors

MR-J3-A Type Amplifiers Cables and Connectors

MR-J3-_A/A1/A4 3.5kW or smaller (200V) and 2kW or smaller (400V)

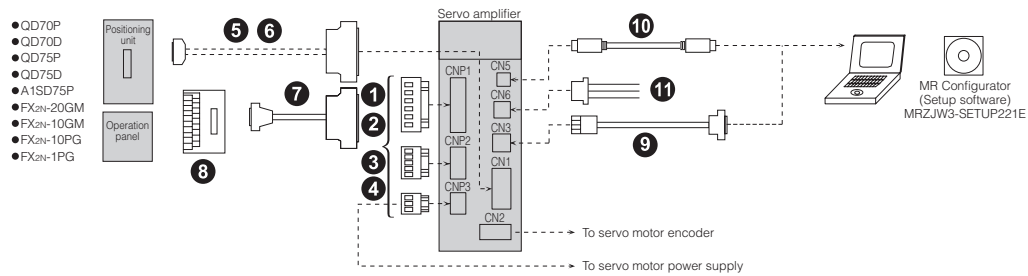



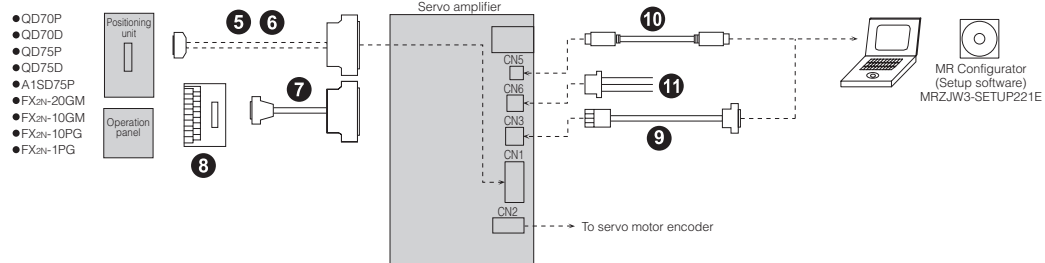

MR-J3-_A/A4 5kW to 22kW (200V) and 3.5kW to 22kW (400V)

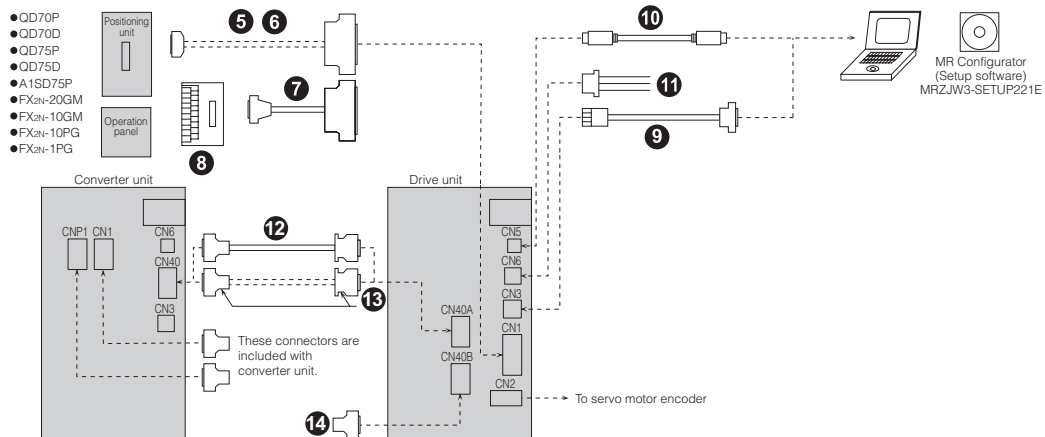

MR-J3-DU_A/A4







MR-J3-A Type Cables and Connectors (Refer to Chart on Previous Page)

Item	Model Number	Stocked Lengths	Protection Level	Description
①	CNP1 Connector 1kW or Less (200VAC)	54928-0670	S	
	CNP1 Connector 2kW - 3.5kW (200VAC)*	PC4/6-STF-7.62	S	
	CNP1 Connector 2kW (200V) (Manufactured after January 2008)	721-207/026-000	S	
	CNP1 Connector 2kW or Less (400VAC)		-	
②	CNP2 Connector up to 3.5kW (200VAC)*	54927-0510	S	
	CNP2 Connector 2kW (200V) (Manufactured after January 2008)	721-205/026-000	S	
	CNP2 Connector 2kW or Less (400VAC)		-	
③	CNP3 Connector 1kW or Less (200VAC)	54928-0370	S	
	CNP3 Connector 2kW - 3.5kW (200VAC)*	PC4/3-STF-7.62	S	
	CNP3 Connector 2kW (200V) (Manufactured after January 2008)	721-203/026-000	S	
CNP3 Connector 2kW or Less (400VAC)	-			
④	CNP1-2-3 Insertion Tool (200VAC)	54932-0000	S	
	CNP1-2-3 Insertion Tool (400VAC)	231-131	S	

* Use this model for amplifiers manufactured prior to January 2008.

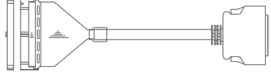
For CN1

Item	Model Number	Stocked Lengths	Protection Level	Description
⑤	CN1 Connector (50 Pin)	MR-J3CN1	-	
⑥	CN1 Pigtail Cable (50 Pin)	MR-J3CCN1CBL- _M _ = cable length 3, 5m	3, 5	
⑦	Junction Terminal Block Cable	MR-J2M-CN1TBL- _M (_ = cable length 0.5, 1m) (For use with MR-TB50 and MR-TB50MIN Junction Terminal Block)	0.5, 1	
⑧	Junction Terminal Block	MR-TB50	S	
		MR-TB50MIN (reduced size - width = 145mm (5.71 in))	S	

For CN3

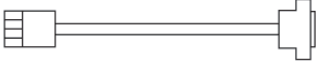
Item	Model Number	Stocked Lengths	Protection Level	Description
⑨	RS-232 to RS-485 Converter PC to CN3 (3M)	SC-FRPC (Cable length 3m)	S	



For CN5

Item	Model Number	Stocked Lengths	Protection Level	Description
⑩	Personal Computer Communication Cable - USB	MR-J3USBCBL3M Cable length 3m	S	

For CN6A

Item	Model Number	Stocked Lengths	Protection Level	Description
⑪	Monitor Cable	MR-J3CN6CBL1M Cable length 1m	S	

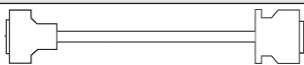
For CN40 (A/B)

Item	Model Number	Stocked Lengths	Protection Level	Description
⑫	Protection Coordination Cable	MR-J3CDL05M	-	
⑬	Connector Set	MR-J2CN1-A	-	
⑭	Terminal Connector	MR-J3-TM	-	

MR-J3-B Safety Type Amplifier Cables and Connectors

For servo amplifier MR-J3-_BS/BS1/BS4 3.5kW or smaller (200V) and 2kW or smaller (400V)

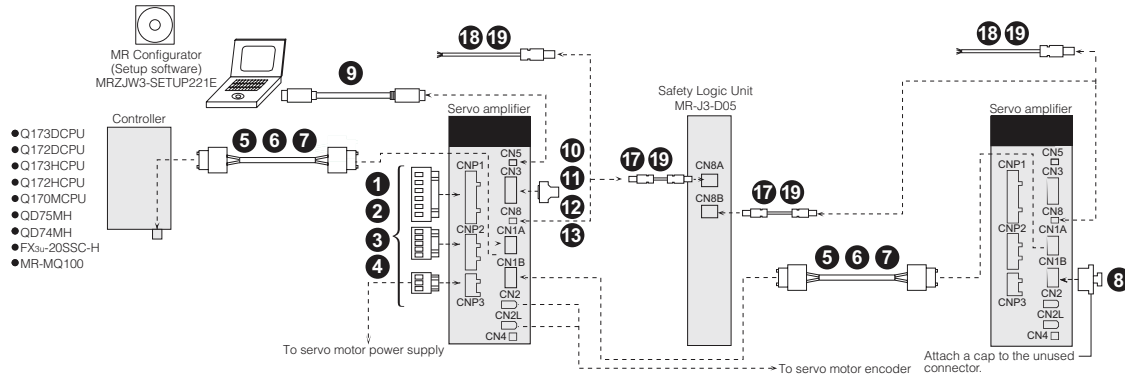

For servo amplifier MR-J3-_BS/BS4 5kW to 22kW (200V) and 3.5kW to 22kW (400V)

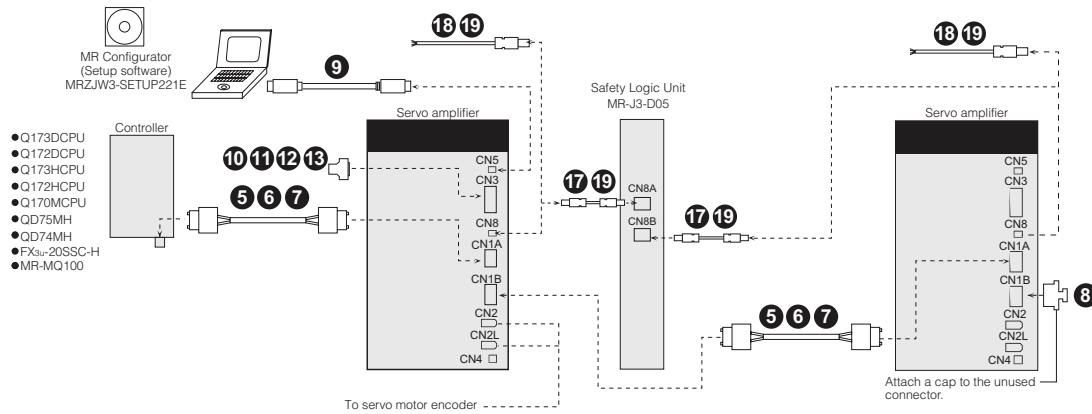



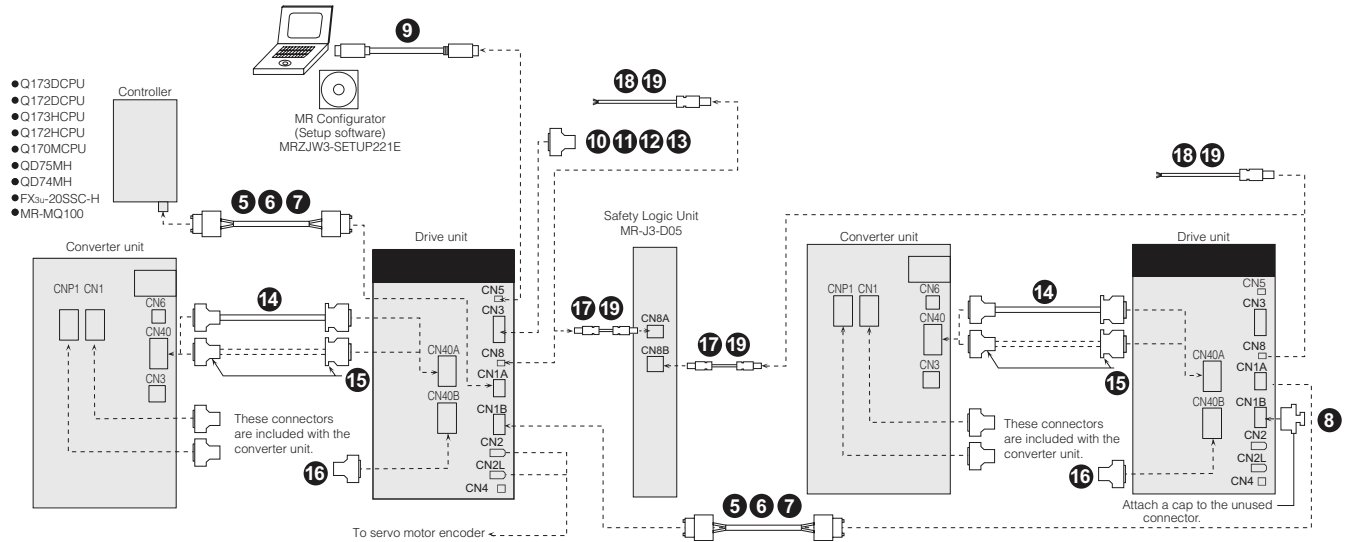

For drive unit MR-J3-DU-_BS/BS4



MR-J3-B Safety Type Cables and Connectors (Refer to Chart on Previous Page)

CNP Connectors (Comes with J3 Amp Standard)

Item	Model Number	Stocked Lengths	Protection Level	Description
1	CNP1 Connector 1kW or Less (200VAC)	54928-0670	S	
	CNP1 Connector 2kW - 3.5kW (200VAC)*	PC4/6-STF-7.62	S	
	CNP1 Connector 2kW (200V) (Manufactured after January 2008)	721-207/026-000	S	
	CNP1 Connector 2kW or Less (400VAC)			
2	CNP2 Connector up to 3.5kW (200VAC)*	54927-0510	S	
	CNP2 Connector 2kW (200V) (Manufactured after January 2008)	721-205/026-000	S	
	CNP2 Connector 2kW or Less (400VAC)			
3	CNP3 Connector 1kW or Less (200VAC)	54928-0370	S	
	CNP3 Connector 2kW - 3.5kW (200VAC)*	PC4/3-STF-7.62	S	
	CNP3 Connector 2kW (200V) (Manufactured after January 2008)	721-203/026-000	S	
	CNP3 Connector 2kW or Less (400VAC)			
4	CNP1-2-3 Insertion Tool (200VAC)	54932-0000	S	
	CNP1-2-3 Insertion Tool (400VAC)	231-131	S	

* Use this model for amplifiers manufactured prior to January 2008.

For Controller, CN1A, CN1B B Safety Type Only

Item	Model Number	Stocked Lengths	Protection Level	Description
5	SSCNET III Cable (Standard Cord For Inside Panel) _ = cable length 0.15, 0.3, 0.5, 1, 3m	0.15, 0.3, 0.5, 1, 3	-	
6	SSCNET III Cable (Standard Cable For Outside Panel) _ = cable length 5, 10, 20m	5, 10, 20	-	
7	SSCNET III Cable (Long Distance Cable) _ = cable length 30, 40, 50m	30	-	





For CN1B

Item	Model Number	Stocked Lengths	Protection Level	Description
8	Connector Cap for SSCNET III	Connector comes with amplifier standard	-	

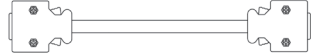

For CN5

Item	Model Number	Stocked Lengths	Protection Level	Description
9	Personal Computer Communication Cable - USB MR-J3USBCBL3M Cable length 3m	S	-	

For CN3

Item	Model Number	Stocked Lengths	Protection Level	Description
10	CN3 Signal Connector (20 Pin)	MR-J2CN1	S	
11	CN3 Pigtail Cable (20 Pin) _ = cable length 3, 5m	MR-CCN1CBL-_M	3, 5	
12	Cable for PS7DW-20V14B-F Terminal Block _ = Cable length 0.5, 1, 3, 5m	MR-J2HBUS_M	0.5, 1, 3, 5	
13	20 Pin Terminal Block For J3-B Safety (TB20 Cannot be Used)	PS7DW-20V14B-F	S	





For CN40

Item	Model Number	Stocked Lengths	Protection Level	Description
14	Protection Coordination Cable MR-J3CDL05M Cable length: 0.5m	-	-	
15	Connector Set	MR-J2CN1-A	-	

Connectors

Item	Model Number	Stocked Lengths	Protection Level	Description	
16	Terminal Connector for CNB40	MR-J3-TM	S	-	

For CN8 and D05

Item	Model Number (_ = cable length in meters)	Stocked Lengths	Protection Level	Diagram	
17	STO Cable (for MR-J3-D05) MR-D05UDL_M _ = cable length: 0.3, 1, 3m	0.3, 1, 3	-		
18	STO cable For Safety Control Device Other than MR-J3-D05 (*2) MR-D05UDL3M-B	S	-		
19	Short-Circuit Connector	Included with Amplifier	-	-	
	Connector	Included with Amplifier	-	-	
	Connector	Included with Amplifier	-	-	

MR-J3-T Type Amplifier Cables and Connectors

MR-J3-_T/T1/T4 3.5kW or smaller (200V) and 2kW or smaller (400V)

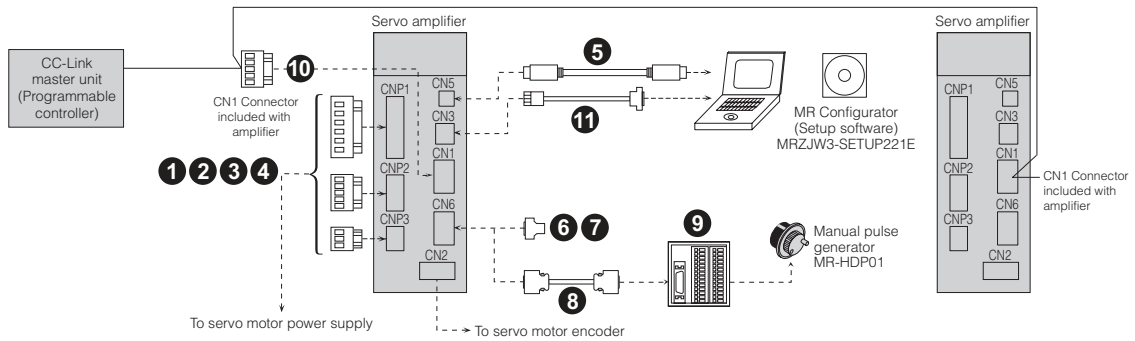

MR-J3-_T/T4 5kW to 22kW (200V) and 3.5kW to 22kW (400V)

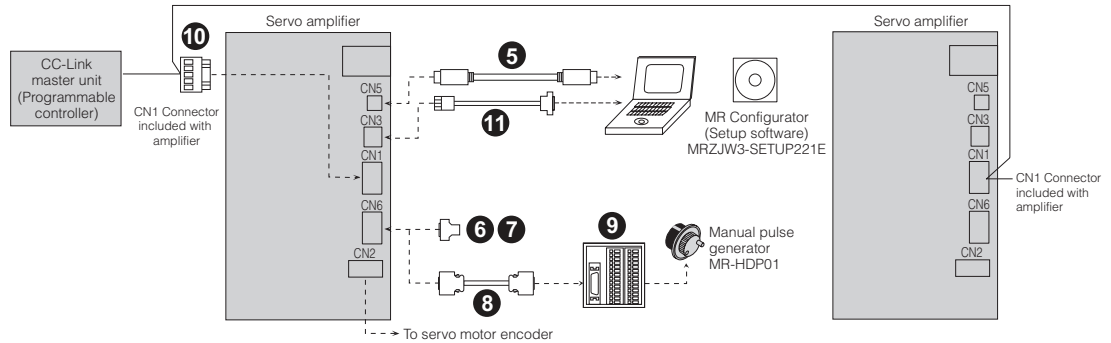

MR-J3-D01 extension IO unit

Options for the servo amplifier are same as when the MR-J3-D01 is not used. Refer to the above illustrations.

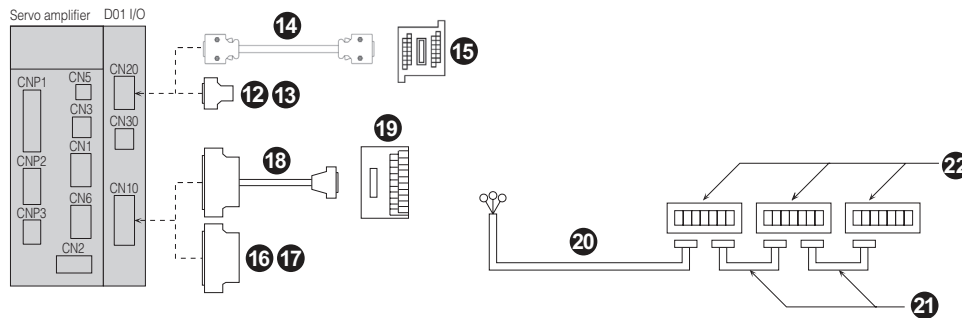

CNP_ Connectors (Comes with J3 Amp Standard)

Item	Model	Stocked Lengths	Protection Level	Description
①	CNP1 Connector 1kW or Less (200VAC)	54928-0670	S	-
	CNP1 Connector 2kW - 3.5kW (200VAC)*	PC4/6-STF-7.62	S	-
	CNP1 Connector 2kW (200V) (Manufactured after January 2008)	721-207/026-000	S	-
	CNP1 Connector 2kW or Less (400VAC)			
②	CNP2 Connector up to 3.5kW (200VAC)*	54927-0510	S	-
	CNP2 Connector 2kW (200V) (Manufactured after January 2008)	721-205/026-000	S	-
	CNP2 Connector 2kW or Less (400VAC)			
③	CNP3 Connector 1kW or Less (200VAC)	54928-0370	S	-
	CNP3 Connector 2kW - 3.5kW (200VAC)*	PC4/3-STF-7.62	S	-
	CNP3 Connector 2kW (200V) (Manufactured after January 2008)	721-203/026-000	S	-
④	CNP1-2-3 Insertion Tool (200VAC)	54932-0000	S	-
	CNP1-2-3 Insertion Tool (400VAC)	231-131	S	-





* Use this model for amplifiers manufactured prior to January 2008.

MR-J3-T Type Cables and Connectors (Refer to Chart on Previous Page)

For CN5

Item	Model Number	Stocked Lengths	Protection Level	Description
5	Personal Computer Communication Cable - USB MR-J3USBCBL3M Cable length 3m	S	-	

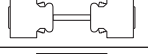
For CN6

Item	Model Number	Stocked Lengths	Protection Level	Description
6	CN6 Connector (26 Pin) MR-ECN1	S	-	
7	CN6 Pigtail Cable (26 Pin) MR-ECN1CBL-3M	S	-	
8	Junction Terminal Block Cable MR-TBNA-TBL_M	0.5, 1	-	
9	Junction Terminal Block MR-TB26A	S	-	



For CN1

Item	Model Number	Stocked Lengths	Protection Level	Description
10	CN1 CC-Link Replacement Connector 1781014	-	-	

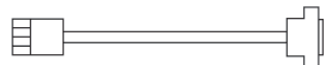

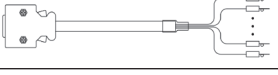
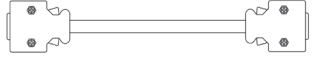

For CN3

Item	Model Number	Stocked Lengths	Protection Level	Description
11	RS-232 to RS-485 Converter PC to CN3 (3M) SC-FRPC Cable length 3m	S	-	



For CN20

Item	Model Number	Stocked Lengths	Protection Level	Description
12	CN20 Signal Connector (20 Pin) MR-J2CN1	S	-	
13	CN20 Pigtail Cable (20 Pin) MR-CCN1CBL-_M _ = cable length 3, 5m	3, 5	-	
14	Cable for PS7DW-20V14B-F Terminal Block MR-J2HBUS_M _ = cable length 0.5, 1, 3, 5m	0.5, 1, 3, 5	-	
15	20 Pin Terminal Block For J3-B (TB20 Cannot be Used) PS7DW-20V14B-F	S	-	

For CN10

Item	Model Number	Stocked Lengths	Protection Level	Description
16	CN10 Connector (50 Pin) MR-J3CN1	-	-	
17	CN10 Pigtail Cable (50 Pin) MR-J3CCN1CBL-_M _ = cable length 3, 5m	3, 5	-	
18	Junction Terminal Block Cable MR-J2M-CN1TBL_M (_ = cable length 0.5, 1m) (For use with MR-TB50 and MR-TB50MIN Junction Terminal Block)	0.5, 1	-	
19	Junction Terminal Block MR-TB50 (reduced size - width = 244mm (9.61 in))	S	-	
	MR-TB50MIN (reduced size - width = 145mm (5.71 in))	S	-	

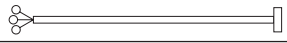
Digital Switch Cables

Item	Model Number	Stocked Lengths	Protection Level	Description
20	Digital Switch Cable (for between MR-DS60 and MR-J3-D01) MR-DSCBL_M-G _ = cable length: 3, 5, 10m	-	-	
21	Digital Switch Cable (for between each MR-DS60) MR-DSCBL _ = cable length: 25, 100cm	-	-	
22	Digital Switch to Use Together With MR-J3-D01 MR-DS60	-	-	

MR-J3W-B Type Amplifier Cables and Connectors

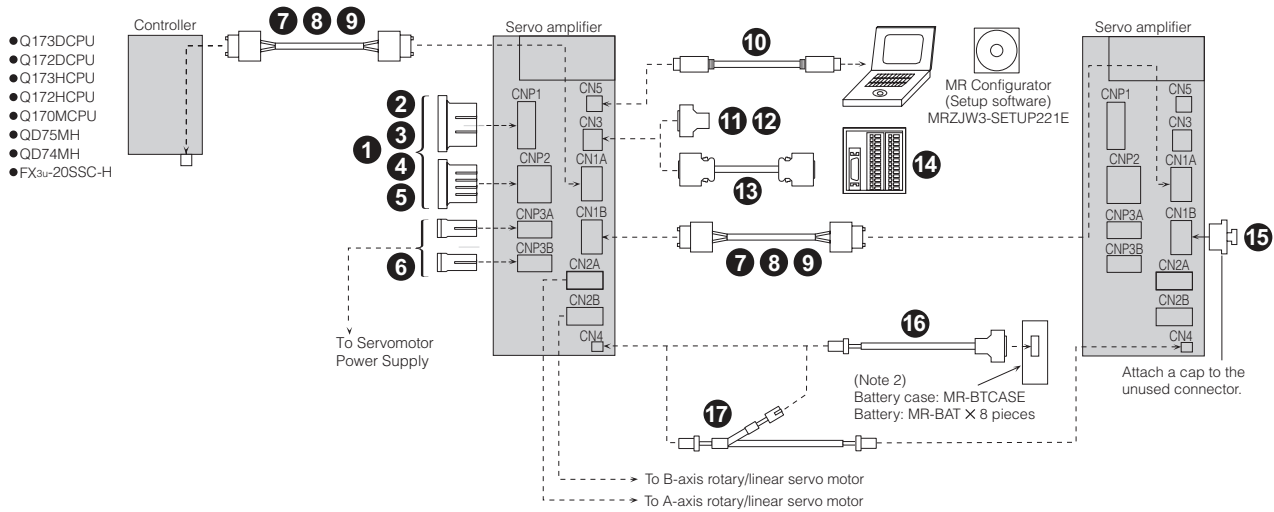

Notes: 1. These connector sets are not included with the servo amplifier. Please purchase them separately.
 2. Battery case (MR-BTCASE) and batteries (MR-BAT) are not required when configuring absolute position detection system with linear servo motor.

CNP1, CNP2-B(Y), CNP2-A(X) Cables

Item	Model	Stocked Lengths	Protection Level	Description
1	CNP1 Main Circuit Power Supply Cable SC-EMP01CBL_M-L _= cable length: 2, 5m (*1, *2)	2, 5	-	Terminal processing type: cut
2	CNP2-B(Y) Control Circuit Power Supply Cable SC-ECP01CBL_M-L _= cable length: 2, 5m (*1, *2)	2, 5	-	Terminal processing type: cut
3	CNP2-A(X) Built-In Regenerative Resistor Short Connector SC-ERG02CBL01M-L	S	-	P+, D
4	CNP2-A(X) Optional Regeneration Unit Cable SC-ERG01CBL_M-L _= cable length: 2, 5m (*1, *2)	2, 5	-	Terminal processing type: cut

Note:
 1. Unlisted length is also available per meter: up to 10m for servo amplifier power supply cable and up to 30m for motor power supply cable.
 2. -H and -L indicate a bending life. -H indicates a long bending life, and -L indicates a standard bending life.

CNP1/CNP2, CNP3A/B Connector Sets

Item	Model	Stocked Lengths	Protection Level	Description
5	CNP1/CNP2 Main Circuit Power Supply Connector Set MR-J3WCNP12-DM	S	-	
6	CNP3A/B Connector Set MR-J3WCNP3-DL	S	-	

For Controller, CN1A, CN1B





Item	Model	Stocked Lengths	Protection Level	Description
7	SSCNET III Cable (Standard Cord For Inside Panel) MR-J3BUS_M _= cable length 0.15, 0.3, 0.5, 1, 3m	0.15, 0.3, 0.5, 1, 3	-	
8	SSCNET III Cable (Standard Cable For Outside Panel) MR-J3BUS_M-A _= cable length 5, 10, 20m	5, 10, 20	-	
9	SSCNET III Cable (Long Distance Cable) MR-J3BUS_M-B _= cable length 30, 40, 50m	30	-	

For CN5

Item	Model	Stocked Lengths	Protection Level	Description
10	Personal Computer Communication Cable - USB MR-J3USBCBL3M Cable length 3m	S	-	

MR-J3W-B Type Cables and Connectors Continued (Refer to Chart on Previous Page)

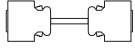
For CN3

Item	Model	Stocked Lengths	Protection Level	Description	
11	CN3 Connector (26 Pin)	MR-ECN1	S	-	
12	CN6 Pigtail Cable (26 Pin)	MR-ECN1CBL-3M	S	-	
13	Junction Terminal Block Cable	MR-TBNATBL_M _ =cable length: 0.5, 1m	S	-	
14	Junction Terminal Block	MR-TB26A	S	-	

For CN1B

Item	Model	Stocked Lengths	Protection Level	Description	
15	Connector Cap for SSCNET III	Connector comes with amplifier standard	-	-	

For CN4

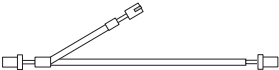
Item	Model	Stocked Lengths	Protection Level	Description	
16	Battery Connection Cable	MR-J3BT1CBL_M _ =cable length: 0.3, 1m	0.3, 1	-	
17	Battery Connection Relay Cable (*1)	MR-J3BT2CBL_M _ =cable length: 0.3, 1m	0.3, 1		

Note:

1. Up to 4 units (8 axes) of MR-J3W-MB servo amplifiers are connectable by using this cable. Refer to "MR-J3W-MB SERVO AMPLIFIER INSTRUCTION MANUAL" for more details.

MR-J3 Motor Cables and Connectors

HF-KP/HF-MP servo motor series: encoder cable length 10m or shorter

- For leading the cables out in a direction of the motor shaft

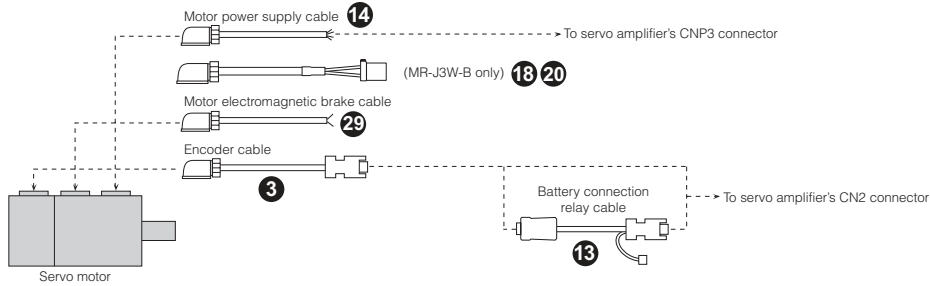

- For leading the cables out in an opposite direction of the motor shaft

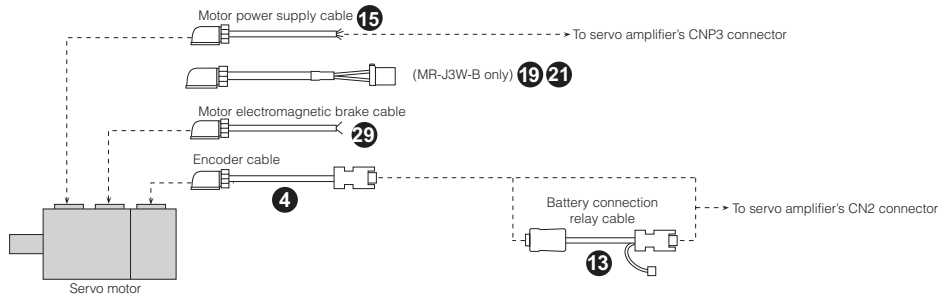

HF-KP/HF-MP servo motor series: encoder cable length over 10m

- For leading the cables out in a direction of the motor shaft

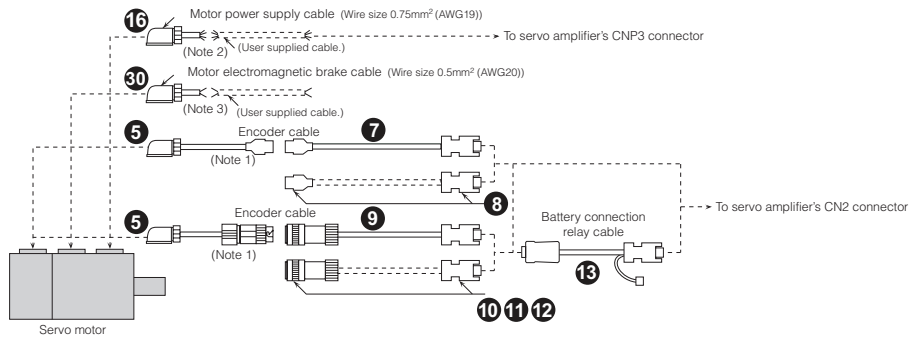

- For leading the cables out in an opposite direction of the motor shaft

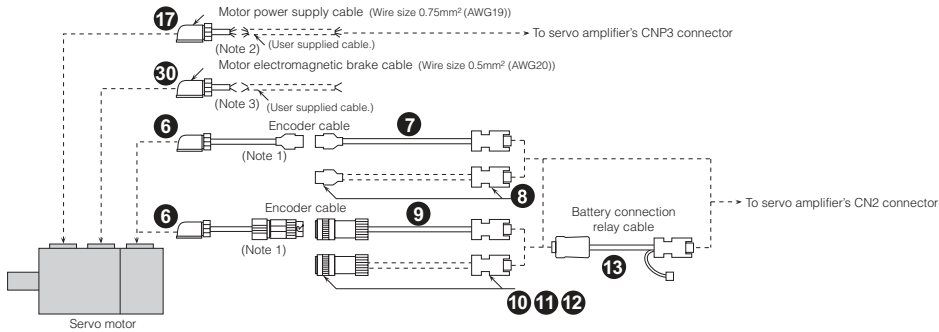

HF-SP servo motor series

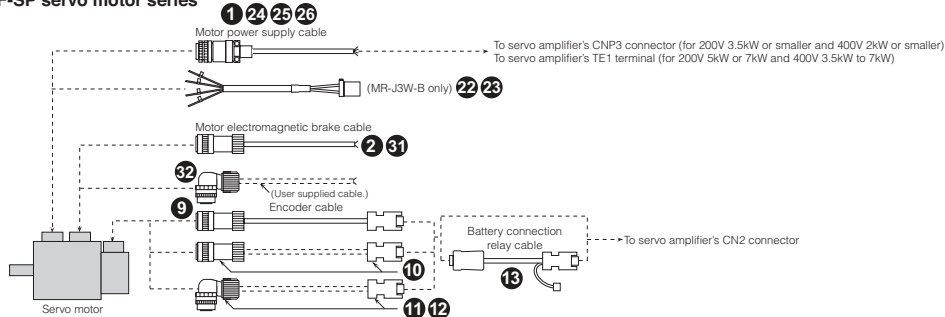

Notes:

1. This cable does not have a long bending life, so always fix the cable before using.
2. If the length exceeds 10m, relay a cable using MR-PWS2CBL03M-A1-L/A2-L cable. This cable does not have a long bending life, so always fix the cable before using. Refer to "MR-J3 SERVO AMPLIFIER INSTRUCTION MANUAL" for details on manufacturing the relay cable.
3. If the length exceeds 10m, relay a cable using MR-BKS2CBL03M-A1-L/A2-L cable. This cable does not have a long bending life, so always fix the cable before using. Refer to "MR-J3 SERVO AMPLIFIER INSTRUCTION MANUAL" for details on manufacturing the relay cable.

MR-J3 Motor Cables and Connectors (continued)

HF-JP servo motor series 5kW or smaller

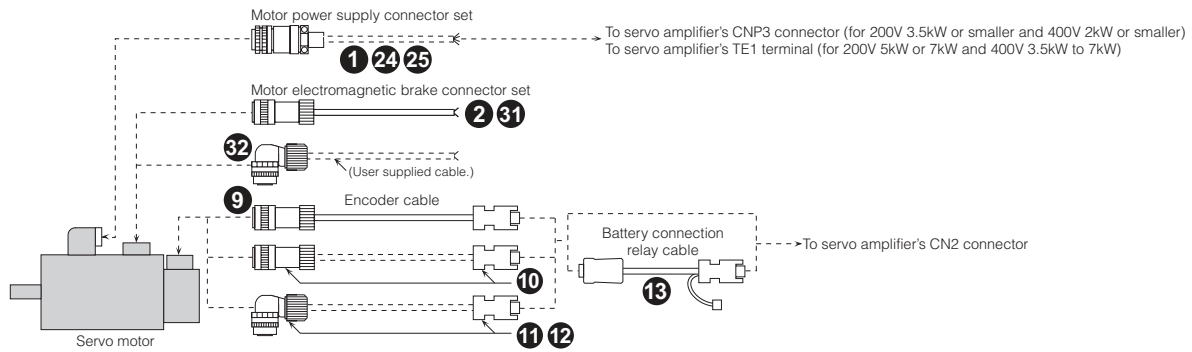

HF-JP servo motor series 11kW and 15kW

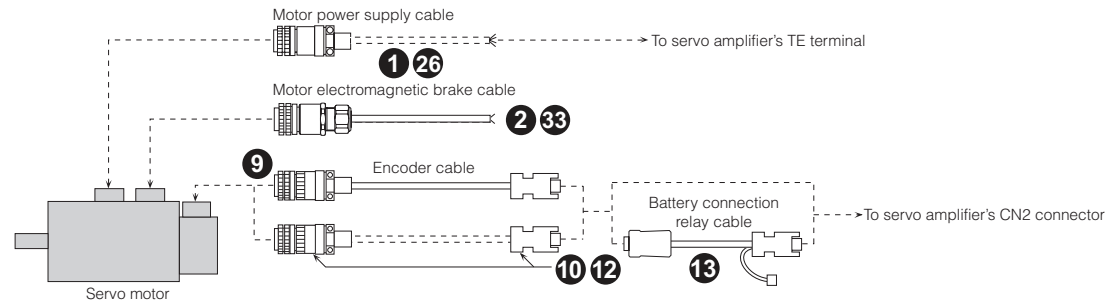

HC-LP/HC-RP/HC-UP servo motor series or HA-LP502/702

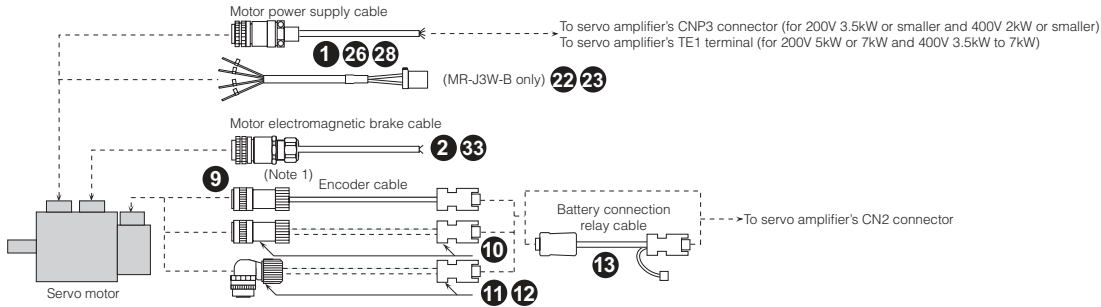

Notes:

1. An electromagnetic brake connector set is not required for HC-RP series and 1.5kW or smaller of HC-LP/HC-UP series as the power supply connector has electromagnetic brake terminals.

HA-LP servo motor series (Note 1)

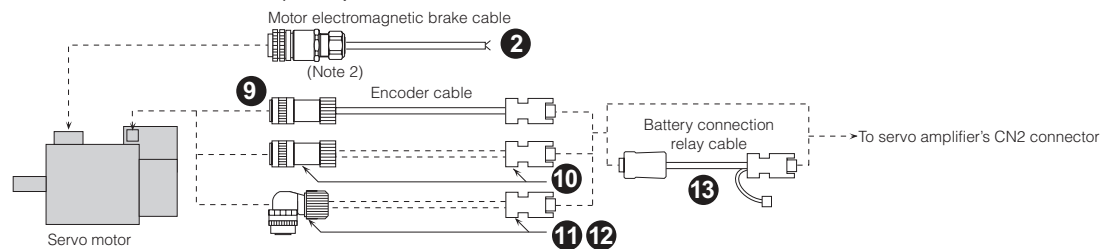

Notes:

1. HA-LP502 and 702 are excluded.

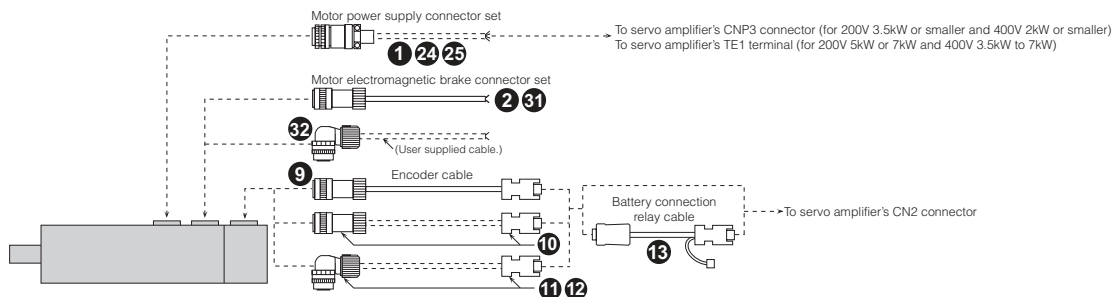

2. Servo motors with an electromagnetic brake are available in 12kW or smaller for HA-LP 1000r/min series, 15kW or smaller for HA-LP 1500r/min series and 11kW to 22kW for HA-LP 2000r/min series.

GSX Exlar actuator series



MR-J3 Cables and Connectors (Refer to Charts on Previous Pages)

Power Cables for HA-LP, HC-LP, HC-RP, HC-UP, HF-SP and HF-JP Series Motors A-, B Safety & T-Type Amplifiers

Item	Motor Model Number	Cable Number (_ = cable length 2, 5, 10, 15, 20, 25, 30 meter)	Stocked Lengths	Protection Level	Description	
1	Standard-Flex, Unshielded Type Cables (Straight Type Connector Only)	HA-LP502	MR-J3HC5S-_M	2M, 5M, 10M, 20M, 30M	IP65	
		HA-LP702	MR-J3P7-_M			
		HA-LP ALL OTHERS	Hard Wired By Customer			
		HC-LP52	MR-J3HC1S-_M	2M, 5M, 10M, 20M, 30M	IP65	
		HC-LP52B	MR-J3HC1SB-_M			
		HC-LP102~152	MR-J3HC2S-_M			
		HC-LP102B~152B	MR-J3HC2SB-_M			
		HC-LP202(B) (*1)	MR-J3HC4S-_M			
		HC-LP302(B) (*1)	MR-J3HC5S-_M			
		HC-RP103~153	MR-J3HC2S-_M	2M, 5M, 10M, 20M, 30M	IP65	
		HC-RP103B~153B	MR-J3HC2SB-_M			
		HC-RP203	MR-J3HC3S-_M			
		HC-RP203B	MR-J3HC3SB-_M			
		HC-RP353~503	MR-J3HC5S-_M			
		HC-RP353B~503B	MR-J3HC5SB-_M			
		HC-UP72	MR-J3HC1S-_M	2M, 5M, 10M, 20M, 30M	IP65	
		HC-UP72B	MR-J3HC1SB-_M			
		HC-UP152	MR-J3HC2S-_M			
		HC-UP152B	MR-J3HC2SB-_M			
		HC-UP202(B) (*1)	MR-J3HC4S-_M			
		HC-UP352(B)~502(B) (*1)	MR-J3HC5S-_M			
		HF-SP51(B)~HF-SP52(4)(B), HF-JP53(B)~HF-JP73(B), HF-JP534(B)~HF-JP1034(B) (*1)	MR-J3P1-_M	2M, 5M, 10M, 20M, 30M	IP65	
		HF-SP81(B)~HF-SP102(4)(B), HF-JP103(B)~HF-JP153(B), HF-JP1534(B), GSX20, GSX30 (*1)	MR-J3P2-_M			
		HF-SP121(B)~HF-SP202(4)(B) (*1)	MR-J3P4-_M			
		HF-SP152(4)(B) (*1)	MR-J3P3-_M			
		HF-SP301(B)~HF-SP352(4)(B) (*1)	MR-J3P5-_M			
		HF-SP502(4)(B), GSX40, GSX50 (*1)	MR-J3P6-_M			
		HF-SP421(B), HF-SP702(4)(B), HF-JP11K1M4(B), GSX60 (*1)	MR-J3P7-_M			
		HF-JP203(B), HF-JP2034(B)~HF-JP3534(B) (*1)	MR-J3P8-_M			
		HF-JP353(B) (*1)	MR-J3P9-_M			
		HF-JP503(B) (*1)	MR-J3P10-_M			
		HF-JP5034(B) (*1)	MR-J3P11-_M			
		HF-JP11K1M(B), HF-JP15K1M4(B) (*1)	MR-J3P12-_M			
		HF-JP15K1M(B) (*1)	MR-J3P13-_M			
HA-LP502	MR-J3HC5S-SH-_M	-	IP65			
HA-LP702	MR-J3PWS7-_M	-	N/A			
HA-LP ALL OTHERS	Hard Wired By Customer	N/A	N/A			
HC-LP52	MR-J3HC1S-SH-_M	-	IP65			
HC-LP52B	MR-J3HC1SB-SH-_M					
HC-LP102~152	MR-J3HC2S-SH-_M					
HC-LP102B~152B	MR-J3HC2SB-SH-_M					
HC-LP202(B) (*1)	MR-J3HC4S-SH-_M					
HC-LP302(B) (*1)	MR-J3HC5S-SH-_M					
HC-RP103~153	MR-J3HC2S-SH-_M	-	IP65			
HC-RP103B~153B	MR-J3HC2SB-SH-_M					
HC-RP203	MR-J3HC3S-SH-_M					
HC-RP203B	MR-J3HC3SB-SH-_M					
HC-RP353~503	MR-J3HC5S-SH-_M					
HC-RP353B~503B	MR-J3HC5SB-SH-_M					
HC-UP72	MR-J3HC1S-SH-_M	-	IP65			
HC-UP72B	MR-J3HC1SB-SH-_M					
HC-UP152	MR-J3HC2S-SH-_M					
HC-UP152B	MR-J3HC2SB-SH-_M					
HC-UP202(B) (*1)	MR-J3HC4S-SH-_M					
HC-UP352(B)~502(B) (*1)	MR-J3HC5S-SH-_M					
HF-SP51(B)~HF-SP52(4)(B), HF-JP53(B)~HF-JP73(B), HF-JP534(B)~HF-JP1034(B) (*1)	MR-J3PWS1-_M	-	IP67			
HF-SP81(B)~HF-SP102(4)(B), HF-JP103(B)~HF-JP153(B), HF-JP1534(B), GSX20, GSX30 (*1)	MR-J3PWS2-_M					
HF-SP121(B)~HF-SP202(4)(B) (*1)	MR-J3PWS4-_M					
HF-SP152(4)(B) (*1)	MR-J3PWS3-_M					
HF-SP301(B)~HF-SP352(4)(B) (*1)	MR-J3PWS5-_M					
HF-SP502(4)(B), GSX40, GSX50 (*1)	MR-J3PWS6-_M					
HF-SP421(B), HF-SP702(4)(B), HF-JP11K1M4(B), GSX60 (*1)	MR-J3PWS7-_M					
HF-JP203(B), HF-JP2034(B)~HF-JP3534(B) (*1)	MR-J3PWS8-_M					
HF-JP353(B) (*1)	MR-J3PWS9-_M					
HF-JP503(B) (*1)	MR-J3PWS10-_M					
HF-JP5034(B) (*1)	MR-J3PWS11-_M					
HF-JP11K1M(B), HF-JP15K1M4(B) (*1)	MR-J3PWS12-_M					
HF-JP15K1M(B) (*1)	MR-J3PWS13-_M					

Note:

1. Must order separate brake cable for these motors.

Brake Cables for - A-, B Safety & T-Type Amplifiers

Item	Motor Model Number	Cable Number (_ = cable length 2, 5, 10, 15, 20, 25, 30 meter)	Stocked Lengths	Protection Level	Description				
2	Standard-Flex, Unshielded Type Cables	HA-LP ALL (B) SIZES	MR-J3HCBKS-_M	2M, 5M, 10M, 20M, 30M	IP65				
		HC-LP202B, 302B							
		HC-UP202B, 352B, 502B							
		HF-JP11K1M(4)B~HF-JP15K1M(4)B							
		HF-SP(4) ALL (B) SIZES							
	High-Flex, Shielded Type Cables	HF-JP53B~HF-JP5034B	MR-J3BK-_M	-	IP67				
		GSX Actuators							
		HA-LP ALL (B) SIZES					MR-J3HCBKS-SH-_M	-	IP65
		HC-LP202B, 302B							
		HC-UP202B, 352B, 502B							
HF-JP11K1M(4)B~HF-JP15K1M(4)B									
HF-SP(4) ALL (B) SIZES									
HF-JP53B~HF-JP5034B	MR-J3BRKS1-_M	-	IP67						
GSX Actuators									

Encoder Cables for A-, B Safety and T-Type



Item	Model	Stocked Lengths	Protection Level	Description
3	Encoder Cable For HF-MP/HF-KP Series Motor Lead Out In Direction Of Motor Shaft MR-J3ENCBL_M-A1-H _ = cable length 2, 5, 10m (*1)	2, 5, 10	IP65	
	MR-J3ENCBL_M-A1-L _ = cable length 2, 5, 10m (*1)	2, 5, 10	IP65	
4	Encoder Cable For HF-MP/HF-KP Series Motor Lead Out In Opposite Direction Of Motor Shaft MR-J3ENCBL_M-A2-H _ = cable length 2, 5, 10m (*1)	2, 5, 10	IP65	
	MR-J3ENCBL_M-A2-L _ = cable length 2, 5, 10m (*1)	2, 5, 10	IP65	
5	Encoder Cable For HF-MP/HF-KP Series Motor Lead Out In Direction Of Motor Shaft MR-J3JCBLO3M-A1-L Cable length 0.3m (*1)	S	IP20	
	MR-J3JSCBLO3M-A1-L Cable length 0.3m (*1, *3)	S	IP67	
6	Encoder Cable For HF-MP/HF-KP Series Motor Lead Out In Opposite Direction Of Motor Shaft MR-J3JCBLO3M-A2-L Cable length 0.3m (*1)	S	IP20	
	MR-J3JSCBLO3M-A2-L Cable length 0.3m (*1, *3)	S	IP67	
7	Amplifier-Side Cable For HF-MP/HF-KP Series Motor MR-EKCBL_M-H _ = cable length 20, 30, 40, 50m (*1)	20, 30	IP20	
	MR-EKCBL_M-L _ = cable length 20, 30m (*1)	-	IP20	
8	Junction Connector, Amplifier-Side Connector (*2) For HF-MP/HF-KP Series Motor MR-ECNM	S	IP20	
9	Encoder Cable For HF-SP, HC-RP, HC-UP, HC-LP, HA-LP, HF-JP53(B)~HF-JP5034(B) Series Motor, GSX Actuators MR-J3ENSCBL_M-H _ = cable length 2, 5, 10, 20, 30, 40, 50m (*1)	2, 5, 10, 20, 30	IP67	
	MR-J3ENSCBL_M-L _ = cable length 2, 5, 10, 20, 30m (*1)	-	IP67	
	Encoder cable for HF-JP11K1M, 15K1M, 11K1M4, 15K1M4, GSX Actuators MR-ENECBL_M-H _ = 2, 5, 10, 20, 30, 40, or 50 (*1)	2, 5, 10	IP67	
	MR-ENECBL_M-L _ = 2, 5, 10, 20, 30, 40, or 50 (*1)	-	IP67	
10	Encoder Connector Set For HF-SP, HC-RP, HC-UP, HC-LP, HA-LP Series Motor, GSX Actuators MR-J3SCNS	S	IP67	
	Encoder connector set for HF-JP11K1M, 15K1M, 11K1M4, 15K1M4, GSX Actuators MR-ENECNS	S	IP67	
11	Encoder connector set for HF-SP/HC-LP/HC-RP/HC-UP/HA-LP Series HF-JP53, 73, 103, 153, 203, 353, 503, 534, 734, 1034, 1534, 2034, 3534, 5034, GSX Actuators MR-J3SCNSA	S	IP67	
12	CN2 or CN2L Connector, GSX Actuators MR-J3CN2	S	IP20	
13	Battery Connection Relay Cable, GSX Actuators MR-J3BTCBLO3M Cable length 0.3m	S	-	

Notes:

- H and -L indicate a bending life. -H indicates a long bending life, and -L indicates a standard bending life.
- The IP rating indicated is for the connector's protection against ingress of dust and water when coupled to a servo amplifier/servo motor. If the IP rating of the servo amplifier/servo motor differs from that of these connectors, overall IP rating depends on the lowest of all.
- The encoder cable is rated IP65 while the junction connector is rated IP67.

MR-J3 Cables and Connectors Continued (Refer to Chart on Previous Page)

Motor Power Supply Cables For CNP3 - A-, B Safety and T-Type

Item			Model (*1)	Stocked Lengths	Protection Level	Description
14	10m Or Shorter (Direct Connection Type)	Power Supply Cable For HF-MP/ HF-KP Series Motor. Lead Out In Direction Of Motor Shaft	MR-PWS1CBL_M-A1-H _ = cable length 2, 5, 10m	2, 5, 10	IP65	
			MR-PWS1CBL_M-A1-L _ = cable length 2, 5, 10m	2, 5, 10	IP65	
Power Supply Cable For HF-MP/ HF-KP Series Motor. Lead Out In Opposite Direction of Motor Shaft		MR-PWS1CBL_M-A2-H _ = cable length 2, 5, 10m	2, 5, 10	IP65		
		MR-PWS1CBL_M-A2-L _ = cable length 2, 5, 10m	2, 5, 10	IP65		
16	Exceeding 10m (Relay Type)	Power Supply Cable For HF-MP/ HF-KP Series Motor Lead Out In Direction Of Motor Shaft	MR-PWS2CBL03M-A1-L (Cable length 0.3m)	S	IP55	
17		Power Supply Cable For HF-MP/ HF-KP Series Motor Lead Out In Opposite Direction Of Motor Shaft	MR-PWS2CBL03M-A2-L (Cable length 0.3m)	S	IP55	

Note:

1. -H and -L indicate bending life. -H indicates a long bending life and -L indicates a standard bending life.

Power Supply Cable for HF-KP/HF-MP Rotary Servo Motor Series (direct connection type)

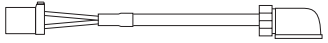
Item			Model (*1)	Stocked Lengths	Protection Level	Description
18	Lead Out in Direction of Motor Shaft Standard Bending Life	Lead Out in Direction of Motor Shaft Standard Bending Life	MR-EPWS1CBL_M-A1-L _ = cable length: 2, 5, 10m	-	-	
19			Lead Out in Opposite Direction of Motor Shaft Standard Bending Life	MR-EPWS1CBL_M-A2-L _ = cable length: 2, 5, 10m	-	
20		Lead Out in Direction of Motor Shaft Long Bending Life	MR-EPWS1CBL_M-A1-H _ = cable length: 2, 5, 10m	2, 5, 10	-	
21		Lead out in Opposite Direction of Motor Shaft Long Bending Life	MR-EPWS1CBL_M-A2-H _ = cable length: 2, 5, 10m	2, 5, 10	-	

Power Supply Cable for HF-SP/HC-LP/HC-UP Rotary Servo Motor Series

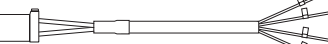
Item			Model (*1)	Stocked Lengths	Protection Level	Description
22	Standard Bending Life	Standard Bending Life	MR-EPWS2CBL_M-L _ = cable length: 2, 5, 10, 20, 30m	-	-	
23			Long Bending Life	MR-EPWS2CBL_M-H _ = cable length: 2, 5, 10, 20, 30m	2, 5, 10	

Note:



1. A separate motor-side power supply connector (listed below) is required for HF-SP/HC-LP/HC-UP rotary servo motors.

Power Supply Connectors

Item			Model Number	Stocked Lengths	Protection Level	Diagram
24		Power Supply Connector Set for HF-SP51, 81, 52, 102, 152, 524, 1024, 1524, HF-JP53, 73, 103, 153, 203, 534, 734, 1034, 1534, 2034, 3534, 5034, GSX20, GSX30	MR-PWCNS4 (straight type only)	S	IP67	
25		Power Supply Connector Set for HF-SP121, 201, 301, 202, 352, 502, 2024, 3524, 5024, HF-JP353, 503, GSX40, GSX50	MR-PWCNS5 (straight type only)	S	IP67	
26		Power Supply Connector Set for HF-SP421, 702, 7024, HF-JP11K1M, 15K1M, 11K1M4, 15K1M4, HA-LP702, GSX60	MR-PWCNS3 (Straight type only)	S	IP67	
27		Power Supply Connector Set for HC-LP52, 102, 152, HC-RP103, 153, 203, HC-UP72, 152,	MR-PWCNS1 (Straight type)	S	IP67	
28		Power Supply Connector Set for HC-LP202, 302, HC-RP353, 503, HC-UP202, 352, 502, HA-LP502	MR-PWCNS2 (Straight type)	S	IP67	

MR-J3 Cables and Connectors Continued (Refer to Chart on Previous Page)



Motor Brake Cables

Item		Model Number (_ =cable length in meters)	Stocked Lengths	Protection Level	Diagram	
29	Brake Cable for HF-KP/HF-MP Series 10m or Shorter (Direct Connection Type)	Lead Out in Direction of Motor Shaft	MR-BKS1CBL_M-A1-H _ = 2, 5, or 10 (*1)	2, 5, 10	IP65	
			MR-BKS1CBL_M-A1-L _ = 2, 5, or 10 (*1)	-	IP65	
		Lead Out in Opposite Direction of Motor Shaft	MR-BKS1CBL_M-A2-H _ = 2, 5, or 10 (*1)	2, 5, 10	IP65	
			MR-BKS1CBL_M-A2-L _ = 2, 5, or 10 (*1)	-	IP65	
30	Brake Cable for HF-KP/HF-MP Series Exceeding 10m (relay type)	Lead Out in Direction of Motor Shaft	MR-BKS2CBL03M-A1-L cable length 0.3 (*1)	S	IP55	
		Lead Out in Opposite Direction of Motor Shaft	MR-BKS2CBL03M-A2-L cable length 0.3 (*1)	S	IP55	

Note:

- H and -L indicate bending life. -H indicates a long bending life and -L indicates a standard bending life.

Brake Connector Set

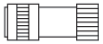
Item	Model Number	Stocked Lengths	Protection Level (*1)	Diagram	
31	Brake Connector Set for HF-SP Series, HF-JP53B, 73B, 103B, 153B, 203B, 353B, 503B, 534B, 734B, 1034B, 1534B, 2034B, 3534B, 5034B, GSX Actuators	MR-BKCNS1 (straight type only)	S	IP67	
32	Brake Connector Set for HF-SP Series, HF-JP53B, 73B, 103B, 153B, 203B, 353B, 503B, 534B, 734B, 1034B, 1534B, 2034B, 3534B, 5034B, GSX Actuators	MR-BKCNS1A (Angled type)	S	IP67	
33	Brake Connector Set for HF-JP11K1MB, 15K1MB, 11K1M4B, 15K1M4B, HC-LP202B, 302B, HC-UP202B, 352B, 502B, HA-LP601B, 801B, 12K1B, 6014B, 8014B, 12K14B, 701MB, 11K1MB, 15K1MB, 701M4B, 11K1M4B, 15K1M4B, 11K2B, 15K2B, 22K2B, 11K24B, 15K24B, 22K24B	MR-BKCN	S	IP65	

Notes:

- The IP rating indicated is for the connector's protection against ingress of dust and water when coupled to a servo amplifier/servo motor. If the IP rating of the servo amplifier/servo motor differs from that of these connectors, overall IP rating depends on the lowest of all.

E Software and Manuals

MR Configurator • (MRZJW3-SETUP221E)

This software makes it easy to perform setup, tuning, monitor display, diagnostics, reading and writing of parameters, and test operations with a personal computer. User-satisfying functions that enable the balance with the machine system, optimum control and short start up time are available.

- This software can set up and tune your servo system easily with a personal computer.
- Multiple monitor functions. Graphic display functions are provided to display the servo motor status with the input signal triggers, such as the command pulse, droop pulse and speed.
- Test operations with a personal computer. Test operation of the servo motors can be performed with a personal computer using multiple test mode menus.
- Further advanced tuning is possible with the improved advanced functions.

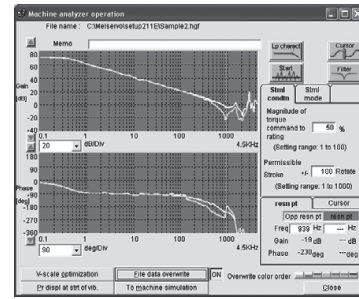

Manuals



Hardware Description	Model Number	Stocked Item
MR-J3-A Instruction Manual	SH(NA)030038	S
MR-J3-B Safety Instruction Manual	SH(NA)030051	S
MR-J3-T Instruction Manual	SH(NA)030058	S
MR-J3-T / MR-J3-D01 Instruction Manual	SH(NA)030061	S
Servo Motor Manual Volume 2	SH(NA)030041	S

Note: Many of these manuals are available for free download from our website, www.meau.com

Description	Model Number	Stocked Item
Windows Communication Software	MR-CONFIGURATOR	S
Communication Cable	MR-J3USBCBL3M	S

F System Options

Extension I/O Unit

Servo Amplifier Type	Model Number	Stocked Item	Description
MR-J3-T Only	MR-J3-D01	S	
MR-J3-B Safety Only	MR-J3-D05	S	

I/O Digital Switch

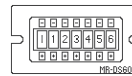
Servo Amplifier Type	Model Number	Stocked Item	Description
MR-J3-D01 Only	MR-DS60	-	

RS-422 Distributor (For Multidrop)

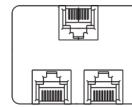
Servo Amplifier Type	Model Number	Stocked Item	Description
MR-J3-A/B Safety/T	BMJ-8	S	

Manual Pulse Generator

Servo Amplifier Type	Model Number	Stocked Item	Description
MR-J3-T Only	MR-HDP01	S	

20 Pin Terminal Block (*1)

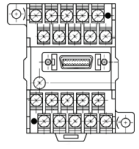

Servo Amplifier Type	Model Number	Stocked Item	Description
MR-J3-B Safety Only	PS7DW-20V14B-F	S	

Note: MR-TB20 terminal block cannot be used for MR-J3-B Safety .

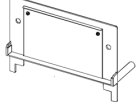
Heat Sink Mounting Attachment

Servo Amplifier Type	Model Number	Stocked Item	Description
MR-J3-11K to 22KA/B Safety /T Only	MR-J3ACN	-	

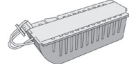
Battery

Item Number	Model Number	Description	Stock Item	Description
Battery	MR-J3BAT	The servo motor's absolute value can be maintained by installing the battery in the servo amplifier. The battery is not required when the servo system is used in an incremental mode.	S	
Battery Connection Relay Cable	MR-J3BTCBL03M	Use this relay cable to hold the absolute value when shipping the product with the machine and servo amplifier removed. The servo motor HF series does not have a super capacitor (for holding an absolute value for short time) in the encoder. When this optional cable is used, the absolute value can be held even when the encoder cable is disconnected from the servo amplifier, making it easy to do maintenance on the servo amplifier.	S	
Diagnostic Cable Only For MR-J3-A Type	MR-J3ACHECK	This cable is required when using the amplifier diagnostic function of MR Configurator (Setup software).	S	

Line Noise Filter

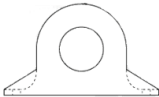
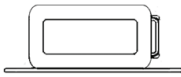
Servo Amplifier Type	Model Number	Stocked Item	Description
MR-J3-200A/B Safety/T(4) or Smaller	FR-BSF01	S	
MR-J3-350A/B Safety/T(4) or Larger	FR-BLF	S	

Radio Noise Filter

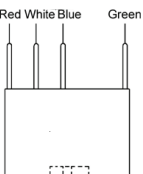
Servo Amplifier Type	Model Number	Stocked Item	Description
All 200VAC J3 Models	FR-BIF	S	
All 400VAC J3 Models	FR-BIF-H	-	

EMC Filter

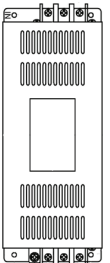
Servo Amplifier Type	Model Number	Stocked Item	Description
MR-J3-100A/BS/T and less	HF3010A-UN	S	
MR-J3-200A/BS/T ~ 350A/BS/T	HF3030A-UN	S	
MR-J3-500A/BS/T ~ 700A/BS/T	HF3040A-UN	S	
MR-J3-11KA/BS/T ~ 22KA/BS/T	HF3100A-UN	S	
MR-J3-DU30 ~ 37KA/BS	HF3200A-UN	-	
MR-J3-100A4/BS4/T4 and less	TF3005C-TX	-	
MR-J3-200 ~ 700A4/BS4/T4	TF3020C-TX	-	
MR-J3-11KA4/BS4/T4	TF3030C-TX	-	
MR-J3-15KA4/BS4/T4	TF3040C-TX	-	
MR-J3-22KA4/BS4/T4	TF3060C-TX	-	
MR-J3-DU30 ~ 55KA4/BS4	TF3150C-TX	-	

External Dynamic Brake

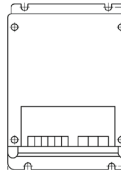
Servo Amplifier Type	Model Number	Stocked Item	Description
MR-J3-11KA/BS/T	DBU-11K	-	
MR-J3-15KA/BS/T	DBU-15K	-	
MR-J3-22KA/BS/T	DBU-22K	-	
MR-J3-11KA4/BS4/T4	DBU-11K-4	-	
MR-J3-15K ~ 22KA4/BS4/T4	DBU-22K-4	S	
MR-J3-DU30KBS ~ DU37KBS	DBU-37K	-	
MR-J3-DU30KBS4 ~ DU55KBS4	DBU-55K-4	-	

Brake/Resistor Units (Must be used in conjunction with each other)

Servo Amplifier Model	Brake Unit Model Number	Stock Item	Resistor Unit Model Number	Stock Item
MR-J3-500A/BS/T to 700A/BS/T	FR-BU2-15K	S	FR-BR-15K-UL	S
MR-J3-11KA/BS/T to 15KA/BS/T	FR-BU2-30K	S	FR-BR-30K-UL	S
MR-J3-22KA/BS/T	FR-BU2-55K	-	FR-BR-55K-UL	-
MR-J3-500 ~ 700A4/BS4/T4	FR-BU2-H15K	S	FR-BR-H15K-UL	S
MR-J3-11K ~ 15KA4/BS4/T4	FR-BU2-H30K	S	FR-BR-H30K-UL	S
MR-J3-22KA4/BS4/T4	FR-BU2-H55K	-	FR-BR-H55K-UL	S

Power Regeneration Converter

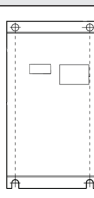
Servo Amplifier Type	Model Number	Stocked Item	Description
MR-J3-500A/BS/T	FR-RC-15K	-	
MR-J3-700A/BS/T ~ 15KA/BS/T	FR-RC-30K	-	
MR-J3-22KA/BS/T	FR-RC-55K	-	
MR-J3-500A4/BS4/T4	FR-RC-H15K	-	
MR-J3-700 ~ 15KA4/BS4/T4	FR-RC-H30K	-	
MR-J3-22KA4/BS4/T4	FR-RC-H55K	-	

Power Regeneration Common Converter/Stand-Alone Reactor

(Must be used in conjunction with each other). Up to six servo amplifiers can be connected to one FR-CV, refer to manuals for details.

Servo Amplifier Model	Common Converter Model Number	Stk Item	Reactor Model Number	Stk Item
MR-J3-350A/B/T	FR-CV-7.5K	-	FR-CVL-7.5K	-
MR-J3-500A/B/T	FR-CV-11K	-	FR-CVL-11K	-
MR-J3-700A/B/T	FR-CV-15K	-	FR-CVL-15K	-
MR-J3-11KA/B/T	FR-CV-22K	-	FR-CVL-22K	-
MR-J3-15KA/B/T	FR-CV-30K	-	FR-CVL-30K	-
	FR-CV-37K	-	FR-CVL-37K	-
MR-J3-22KA/B/T	FR-CV-55K	-	FR-CVL-55K	-

200VAC Optional Regeneration Resistors

Servo Amplifier Model MR-J3-__	Built-in Regenerative Resistor/Tolerable Regenerative Power (W)	Standard Resistors Supplied with Amplifiers				Optional Regeneration Resistors/Tolerable Regenerative Power (W)												
		GRZG400-				MR-RB												
		0.8ΩX4 (*2)	0.8ΩX4 (*2)	0.9ΩX5 (*2)	0.6ΩX5 (*2)	032 (40Ω)	12 (40Ω)	30 (13Ω)	31 (6.7Ω)	32 (40Ω)	50 (13Ω) (*1)	51 (6.7Ω) (*1)	5E (6Ω) (*2)	5R (3.2Ω) (*2)	9P (4.5Ω) (*2)	9F (3Ω) (*2)	139 (1.3Ω)	137 (1.3Ω) (*3)
Stocked Item	-	-	-	-	S	S	S	-	S	S	S	-	-	-	-	-	-	
10A(1)/BS(1)/T(1)	-	-	-	-	30	-	-	-	-	-	-	-	-	-	-	-	-	
20A(1)/BS(1)/T(1)	10	-	-	-	30	100	-	-	-	-	-	-	-	-	-	-	-	
40A(1)/BS(1)/T(1)	10	-	-	-	30	100	-	-	-	-	-	-	-	-	-	-	-	
60A/BS/T	10	-	-	-	30	100	-	-	-	-	-	-	-	-	-	-	-	
70A/BS/T	20	-	-	-	30	100	-	-	300	-	-	-	-	-	-	-	-	
100A/BS/T	20	-	-	-	30	100	-	-	300	-	-	-	-	-	-	-	-	
200A/BS/T	100	-	-	-	-	-	300	-	-	500	-	-	-	-	-	-	-	
350A/BS/T	100	-	-	-	-	-	300	-	-	500	-	-	-	-	-	-	-	
500A/BS/T	130	-	-	-	-	-	-	300	-	-	500	-	-	-	-	-	-	
700A/BS/T	170	-	-	-	-	-	-	300	-	-	500	-	-	-	-	-	-	
11KA/BS/T	-	500 (800)	-	-	-	-	-	-	-	-	-	500 (800)	-	-	-	-	-	
11KA/BS/T-LR	-	-	500 (800)	-	-	-	-	-	-	-	-	-	500 (800)	-	-	-	-	
15KA/BS/T	-	-	-	850 (1300)	-	-	-	-	-	-	-	-	-	850 (1300)	-	-	-	
15KA/BS/T-LR	-	-	-	-	850 (1300)	-	-	-	-	-	-	-	-	-	850 (1300)	-	-	
22KA/BS/T	-	-	-	-	850 (1300)	-	-	-	-	-	-	-	-	-	850 (1300)	-	-	
DU30KA/BS	-	-	-	-	-	-	-	-	-	-	-	-	-	-	-	1300	3900	
DU37KA/BS	-	-	-	-	-	-	-	-	-	-	-	-	-	-	-	1300	3900	

400VAC Optional Regeneration Resistors

Servo Amplifier Model MR-J3-__	Built-in Regenerative Resistor/Tolerable Regenerative Power (W)	Standard Resistors Supplied with Amplifiers				Optional Regeneration Resistors/Tolerable Regenerative Power (W)												
		GRZG400-				MR-RB												
		5ΩX4 (*2)	2.5ΩX4 (*2)	2.5ΩX5 (*2)	2ΩX5 (*2)	1H-4 (82Ω)	3M-4 (120Ω) (*1)	3G-4 (47Ω) (*1)	34-4 (26Ω) (*1)	5G-4 (47Ω) (*1)	54-4 (26Ω) (*1)	5K-4 (10Ω) (*2)	6B-4 (20Ω) (*2)	60-4 (12.5Ω) (*2)	6K-4 (10Ω) (*2)	136-4 (5Ω)	138-4 (5Ω) (*3)	
Stocked Item	-	-	-	-	-	S	S	S	S	S	-	S	-	-	-	-		
60A4/BS4/T4	15	-	-	-	100	300	-	-	-	-	-	-	-	-	-	-		
100A4/BS4/T4	15	-	-	-	100	300	-	-	-	-	-	-	-	-	-	-		
200A4/BS4/T4	100	-	-	-	-	-	300	-	500	-	-	-	-	-	-	-		
350A4/BS4/T4	100	-	-	-	-	-	300	-	500	-	-	-	-	-	-	-		
500A4/BS4/T4	130 (*4)	-	-	-	-	-	-	300	-	500	-	-	-	-	-	-		
700A4/BS4/T4	170 (*4)	-	-	-	-	-	-	300	-	500	-	-	-	-	-	-		
11KA4/BS4/T4	-	500 (800)	-	-	-	-	-	-	-	-	-	500 (800)	-	-	-	-		
11KA4/BS4/T4-LR	-	-	500 (800)	-	-	-	-	-	-	-	500 (800)	-	-	-	-	-		
15KA4/BS4/T4	-	-	-	850 (1300)	-	-	-	-	-	-	-	-	850 (1300)	-	-	-		
15KA4/BS4/T4-LR	-	-	-	-	850 (1300)	-	-	-	-	-	-	-	-	850 (1300)	-	-		
22KA4/BS4/T4	-	-	-	-	850 (1300)	-	-	-	-	-	-	-	-	850 (1300)	-	-		
DU30KA4/BS4	-	-	-	-	-	-	-	-	-	-	-	-	-	-	1300	3900		
DU37KA4/BS4	-	-	-	-	-	-	-	-	-	-	-	-	-	-	1300	3900		
DU45KA4/BS4	-	-	-	-	-	-	-	-	-	-	-	-	-	-	1300	3900		
DU55KA4/BS4	-	-	-	-	-	-	-	-	-	-	-	-	-	-	1300	3900		

Notes:

1. Be sure to install cooling fans.
2. This applies when the GRZG400-Ω regeneration resistors are used as a standard accessory and parameter PA02 is changed with cooling fan (1.0m³/min, the _92 x 2 unit) installed.
3. MR-RB137 is three resistance values combined.
4. MR-RB138-4 is three resistance values combined.

Dual Axis Optional Regeneration Resistors

Servo Amplifier Model	MR-RB14 (26Ω)	MR-RB34 (26Ω)
MR-J3W-22B	-	-
MR-J3W-44B	100	-
MR-J3W-77B	-	300

DC Power Improvement Reactor

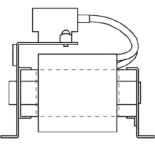
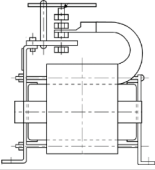
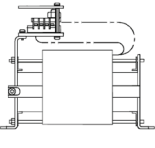
Servo Amplifier Type	Model Number	Stock Item	Description	
MR-J3-10 ~ 20A/B/T	DCA000402	-		
MR-J3-40A/B/T	DCA000902	-		
MR-J3-60 ~ 70A/B/T		-		
MR-J3-100A/B/T	DCA001202	-		
MR-J3-200A/B/T	DCA001802	-		
MR-J3-350A/B/T	DCA003202	-		
MR-J3-500A/B/T	DCA005001	-		
MR-J3-60A4/B4/T4	DCA000402	-		
MR-J3-100A4/B4/T4	DCA000903	-		
MR-J3-200A4/B4/T4		-		
MR-J3-350A4/B4/T4	DCA001803	-		
MR-J3-500A4/B4/T4	DCA002503	-		
MR-J3-700 ~ 11KA/B/T	DCA008002	-		
MR-J3-15KA/B/T	DCA011003	-		
MR-J3-22KA/B/T	DCA012502	-		
MR-J3-700 ~ 11KA4/B4/T4	DCA003202	-		
MR-J3-15KA4/B4/T4	DCA005004	-		
MR-J3-22KA4/B4/T4	DCA008005	-		
MR-J3-DU30KA/B	MR-DCL30K	-		
MR-J3-DU37KA/B	MR-DCL37K	-		
MR-J3-DU30KA4/B4	MR-DCL30K-4	-		
MR-J3-DU37KA4/B4	MR-DCL37K-4	-		
MR-J3-DU45KA4/B4	MR-DCL45K-4	-		
MR-J3-DU55KA4/B4	MR-DCL55K-4	-		

AC Power Factor Improvement Reactor

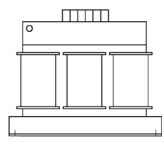
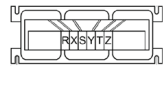
Servo Amplifier Type	Model Number	Stock Item	Description
MR-J3-10A1/B1/T1	MRL-00204	-	
MR-J3-10 ~ 20A/B/T		-	
MR-J3-20A1/B1/T1	MRL-00401	-	
MR-J3-40A/B/T		-	
MR-J3-40A1/B1/T1	MRL-00801	-	
MR-J3-60 ~ 70A/B/T		-	
MR-J3-100A/B/T	MRL-01201	-	
MR-J3-200A/B/T	MRL-01801	S	
MR-J3-350A/B/T	MRL-03501	-	
MR-J3-500A/B/T	MRL-04501	-	
MR-J3-700 ~ 11KA/B/T	MRL-05501	-	
MR-J3-15KA/B/T	MRL-08001	-	
MR-J3-22KA/B/T	MRL-10001	-	
MR-J3-60A4/B4/T4	MRL-00402	S	
MR-J3-100A4/B4/T4		-	
MR-J3-200A4/B4/T4	MRL-00802	S	
MR-J3-350A4/B4/T4	MRL-01802	S	
MR-J3-500A4/B4/T4	MRL-02502	S	
MR-J3-700 ~ 11KA4/B4/T4	MRL-03502	S	
MR-J3-15KA4/B4/T4	MRL-04502	S	
MR-J3-22KA4/B4/T4	MRL-05502	-	

MR-J3 Motor Shaft Details and Servomotor Dimensions

HF-KP / HF-MP Series: D-Cut Shaft (50W & 100W Motors Only)

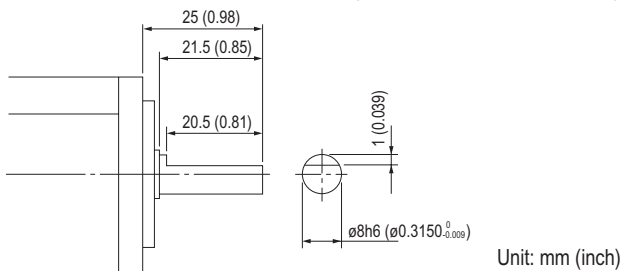

Keyway With Key Included

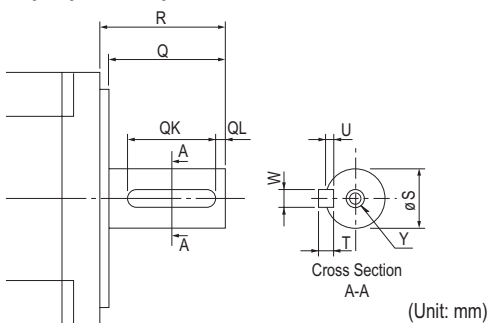

Motor Model	Capacity (W)	Variable Dimensions								
		T	S	R	Q	W	QK	QL	U	Y
HF-KP_K HF-MP_K	200, 400	5 (0.20)	14h6 (0.554)	30 (1.18)	27 (1.06)	5 (0.20)	20 (0.79)	3 (0.12)	3 (0.12)	M4 Depth 15 (0.59)
	750	6 (0.24)	19h6 (0.7480)	40 (1.57)	37 (1.46)	6 (0.24)	25 (0.98)	5 (0.20)	3.5 (0.14)	M5 Depth 20 (0.79)

HF-SP / HF-JP / HC-LP / HC-RP/ HC-UP / HA-LP Series

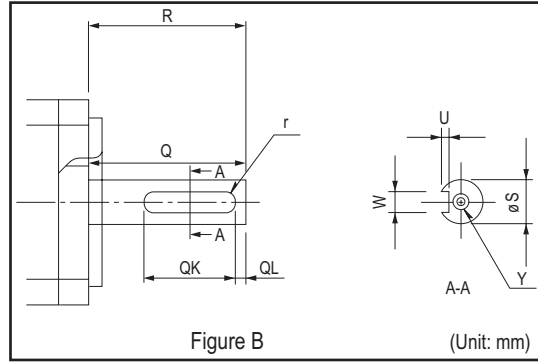
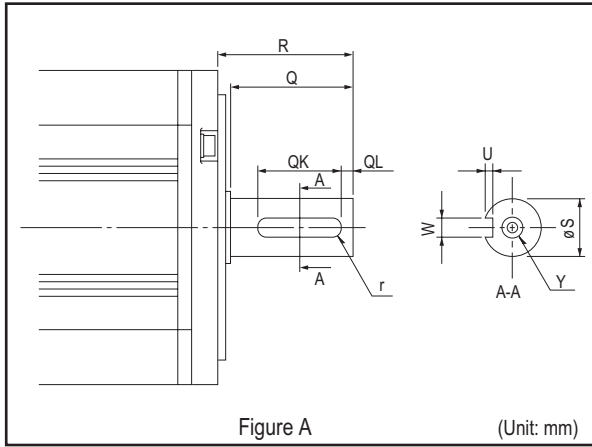

Keyway With No Key Supplied (Customer must supply key or order key part separately below)

Motor Model	Capacity (kW)	Variable Dimensions mm (in)									Fig.	Key Dimensions	Key Model Number	Stocked Item	
		S	R	Q	W	QK	QL	U	r	Y					
HF-SP_K HC-LP_K	0.5~1.5	24h6 (0.9449 ⁰ _{-0.0005})	55 (2.17)	50 (1.91)	8 ⁰ _{-0.036} (0.315 ⁰ _{-0.001})	36 (1.42)	5 (0.20)	4 ^{+0.2} ₀ (0.16 ^{+0.008} ₀)	4 (0.16)	M8 Depth 20 (0.79)	A	8x7x28	MTR KEY 8-7-28	S	
	2.0~7.0	35h6 ^{+0.01} ₀ (1.3780 ^{+0.0004} ₀)	79 (3.11)	75 (2.95)	10 ⁰ _{-0.036} (0.394 ⁰ _{-0.001})	55 (2.17)	5 (0.20)	5 ^{+0.2} ₀ (0.20 ^{+0.008} ₀)	5 (0.20)			10x8x45	MTR KEY 10-8-45	S	
HC-RP_K	1.0, 1.5, 2.0	24h6 (0.9449 ⁰ _{-0.0005})	45 (1.77)	40 (1.57)	8 ⁰ _{-0.036} (0.315 ⁰ _{-0.001})	25 (0.98)	5 (0.20)	4 ^{+0.2} ₀ (0.16 ^{+0.008} ₀)	4 (0.16)			8x7x16	MTR KEY 8-7-16	S	
	3.5, 5.0	28h6 (1.1024 ⁰ _{-0.0005})	63 (2.48)	58 (2.28)	8 ⁰ _{-0.036} (0.315 ⁰ _{-0.001})	53 (2.09)	3 (0.12)	4 ^{+0.2} ₀ (0.16 ^{+0.008} ₀)	4 (0.16)			8x7x45	MTR KEY 8-7-45	S	
HC-UP_K	0.75	22h6 (0.8661 ⁰ _{-0.0005})	55 (2.17)	50 (1.97)	6 ⁰ _{-0.036} (0.236 ⁰ _{-0.001})	42 (1.65)	3 (0.12)	3.5 ^{+0.1} ₀ (0.14 ^{+0.008} ₀)	3 (0.12)			6x6x36	MTR KEY 6-6-36	S	
	1.5	28h6 (1.1024 ⁰ _{-0.0005})	55 (2.17)	50 (1.97)	8 ⁰ _{-0.036} (0.315 ⁰ _{-0.001})	40 (2.09)	3 (0.12)	4 ^{+0.2} ₀ (0.16 ^{+0.008} ₀)	4 (0.16)			8x7x36	MTR KEY 8-7-36	S	
	2.0, 3.5, 5.0	35 ^{+0.1} ₀ (1.3780 ^{+0.0004} ₀)	65 (2.56)	60 (2.36)	10 ⁰ _{-0.036} (0.394 ⁰ _{-0.001})	50 (1.97)	5 (0.20)	5 ^{+0.2} ₀ (0.20 ^{+0.008} ₀)	5 (0.20)			10x8x45	MTR KEY 10-8-45	S	
HF-JP_K	0.5~2.0	16h6	40 (1.57)	30 (1.18)	5 ⁰ _{-0.030}	25 (0.98)	2 (0.08)	3 ^{+0.1} ₀	2.5 (0.10)			M4	-	-	-
	3.5, 5	28h6 (1.1024 ⁰ _{-0.0005})	55 (2.17)	50 (1.97)	8 ⁰ _{-0.036} (0.315 ⁰ _{-0.001})	36 (1.42)	5 (0.20)	4 ^{+0.2} ₀ (0.16 ^{+0.008} ₀)	4 (0.16)			M8	8x7x28	MTR KEY 8-7-28	S
	11, 15	55M6 (2.1654 ^{+0.0012} _{-0.0008})	116 (4.57)	110 (4.33)	16 ⁰ _{-0.04} (0.63 ⁰ _{-0.002})	90 (3.54)	5 (0.20)	6 ^{+0.2} ₀ (0.24 ^{+0.008} ₀)	8 (0.31)			M10	-	-	-

Keyway With No Key Supplied (Customer must supply key)

Motor Model (HA-LP_K)	Variable Dimensions mm (in)									Fig.	Key Model Number	
	S	R	Q	W	QK	QL	U	r	Y			
601, 6014, 701M, 701M4, 502, 702, 11K2, 11K24	42h6 (1.6535 ⁰ _{-0.0006})	85 (3.35)	80 (3.15)	12 ⁰ _{-0.04} (0.47 ⁰ _{-0.002})	70 (2.76)	5 (0.20)	5 ^{+0.2} ₀ (0.2 ^{+0.008} ₀)	6 (0.24)	Same as Standard motor's straight shaft.	A	(N/A) Key to be supplied by customer.	
801, 12K1, 8014, 12K14, 11K1M, 15K1M, 11K1M4, 15K1M4, 15K2, 22K2, 15K24, 22K24	55m6 (2.1654 ^{+0.0012} _{-0.0006})	110 (4.33)	100 (3.94)	16 ⁰ _{-0.04} (0.63 ⁰ _{-0.002})	90 (3.54)	5 (0.20)	6 ^{+0.2} ₀ (0.24 ^{+0.008} ₀)	8 (0.31)				
15K1, 20K1, 15K14, 20K14, 22K1M, 30K1M, 22K1M4, 30K1M4, 30K2, 37K2, 30K24, 37K24	60m6 (2.3622 ^{+0.0012} _{-0.0006})	140 (5.51)	140 (5.51)	18 ⁰ _{-0.04} (0.71 ⁰ _{-0.002})	128 (5.04)	6 (0.24)	7 ^{+0.2} ₀ (0.28 ^{+0.008} ₀)	9 (0.35)				
25K1, 30K1, 25K14, 30K14, 37K1M, 37K1M4, 45K1M4, 45K24, 55K24	65m6 (2.5591 ^{+0.0012} _{-0.0006})	140 (5.51)	140 (5.51)	18 ⁰ _{-0.04} (0.71 ⁰ _{-0.002})	128 (5.04)	6 (0.24)	7 ^{+0.2} ₀ (0.28 ^{+0.008} ₀)	9 (0.35)				B
37K1, 37K14, 50K1M4	80m6 (3.1496 ⁰ _{-0.0006})	170 (6.69)	170 (6.69)	22 ⁰ _{-0.04} (0.87 ⁰ _{-0.002})	147 (5.79)	11 (0.43)	9 ^{+0.2} ₀ (0.35 ^{+0.008} ₀)	11 (0.43)				

Note: Not all key sizes are available to order from MEAU. If a key part is not listed, customer must supply.

HF-KP / HF-MP Series

HF-KP053(B), HF-KP13(B)
HF-MP053(B), HF-MP13(B)

(Unit: mm)

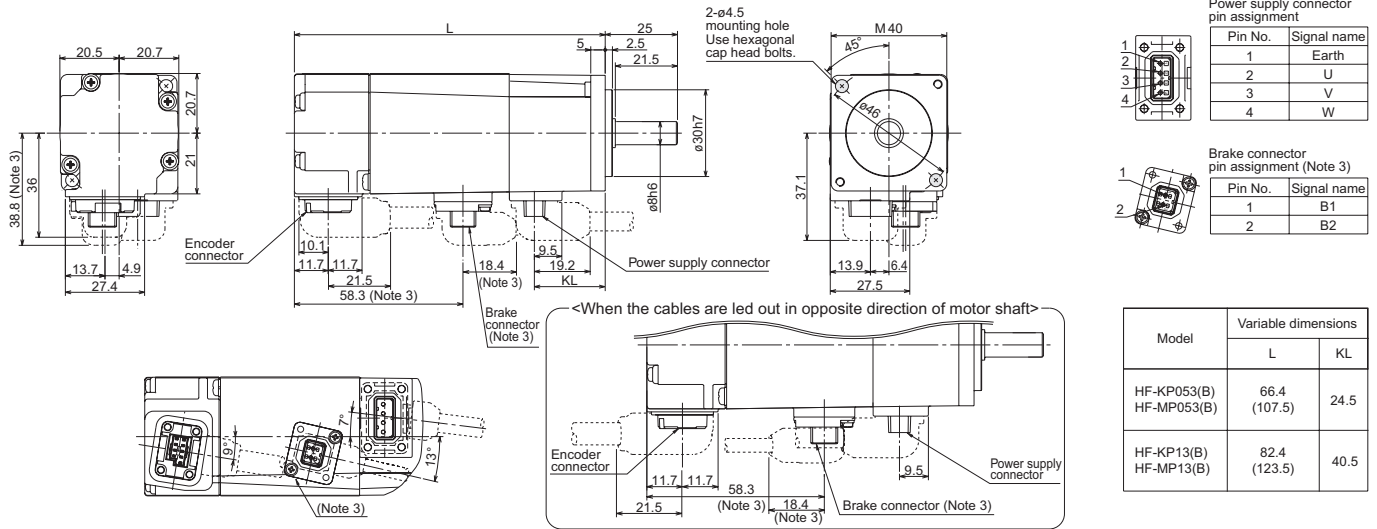

HF-KP23(B), HF-KP43(B)
HF-MP23(B), HF-MP43(B)

(Unit: mm)

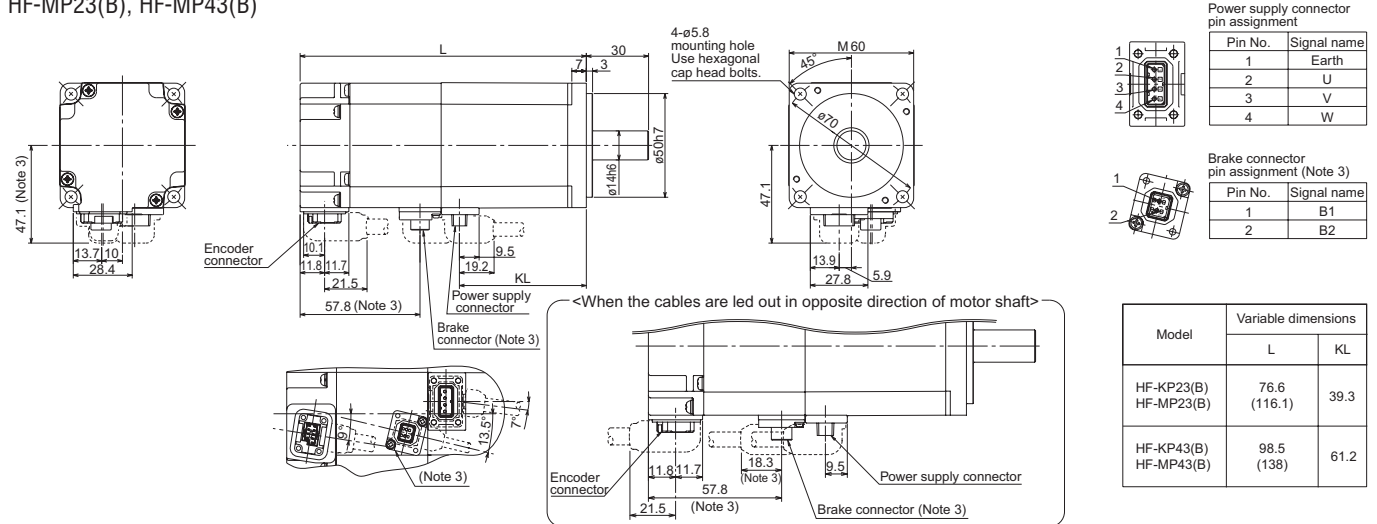

HF-KP73(B)
HF-MP73(B)

(Unit: mm)

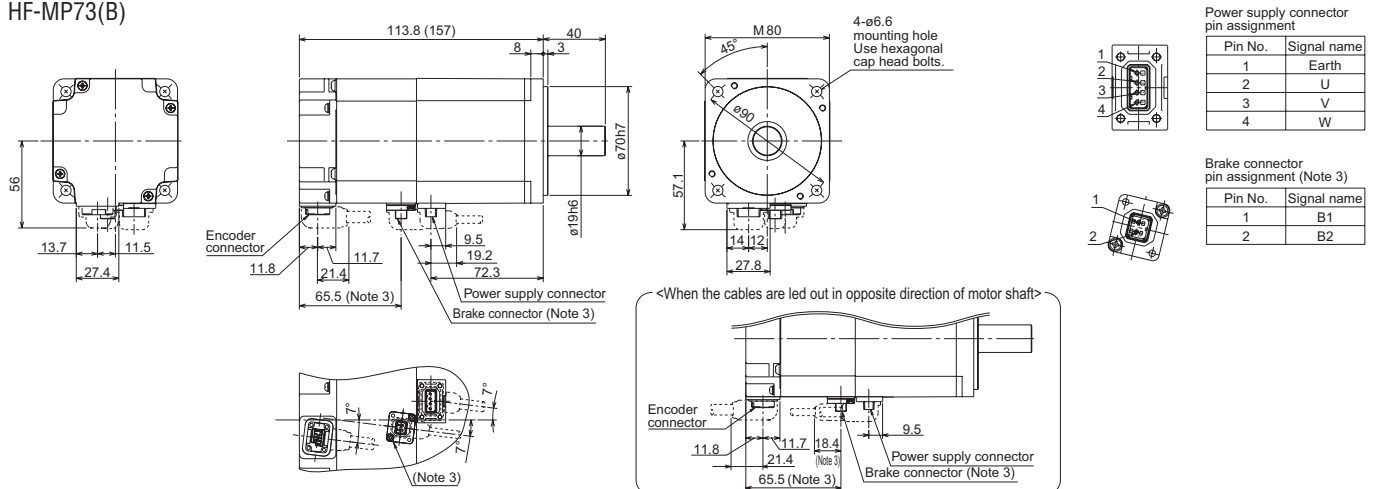

Notes:

- Use a friction coupling to fasten a load.
- Dimensions inside () are for the models with an electromagnetic brake.
- Only for the models with an electromagnetic brake. The electromagnetic brake terminals (B1, B2) do not have the polarity.
- For dimensions where there is no tolerance listed, use general tolerance.
- Dimensions for motors with an oil seal (HF-MP_J and HF-KP_J) are different from the above. Contact Mitsubishi for details.

HF-SP Series

HF-SP51(B), HF-SP81(B)
HF-SP52(B) to HF-SP152(B), HF-SP524(B) to HF-SP152(B)

(Unit: mm)

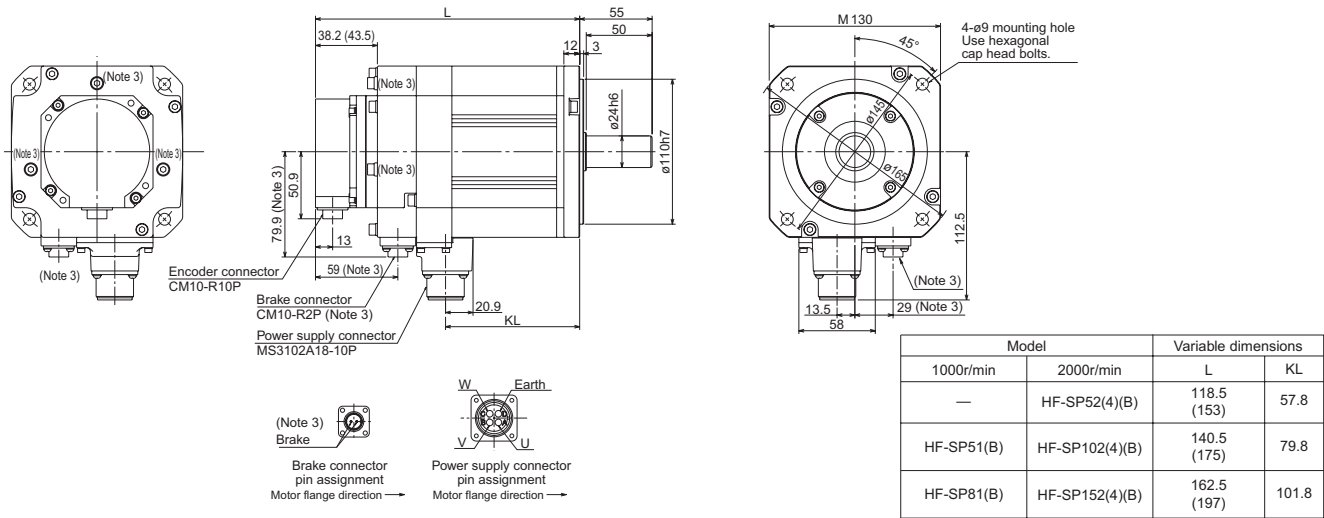

HF-SP121(B) to HF-SP421(B)
HF-SP202(B) to HF-SP702(B), HF-SP2024(B) to HF-SP7024(B) HF-MP73(B)

(Unit: mm)

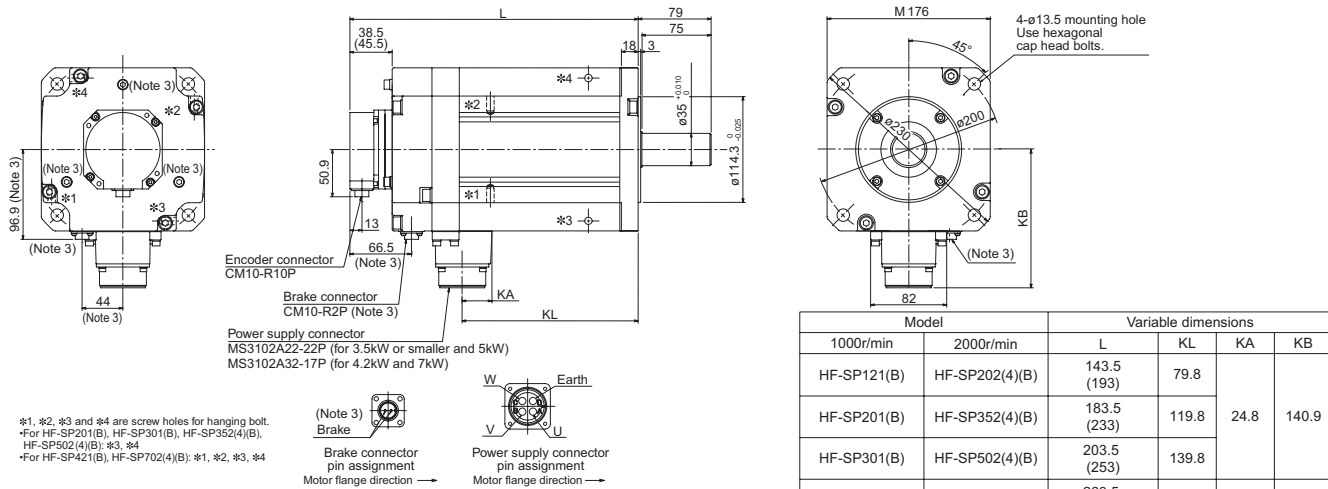

Notes:

- Use a friction coupling to fasten a load.
- Dimensions inside () are for the models with an electromagnetic brake.
- Only for the models with an electromagnetic brake. The electromagnetic brake terminals do not have the polarity.
- For dimensions where there is no tolerance listed, use general tolerance.

HF-JP Series

HF-JP53(B), HF-JP73(B), HF-JP103(B), HF-JP153(B), HF-JP203(B)

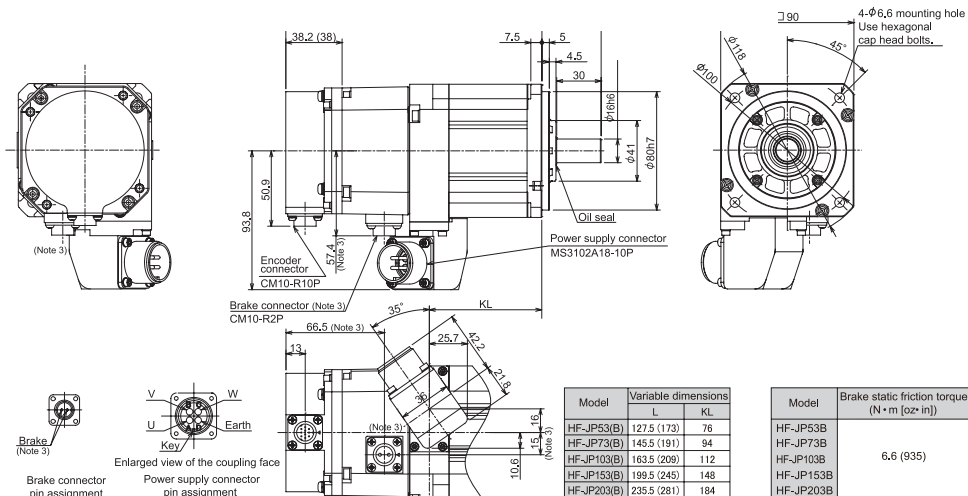

HF-JP353(B), HF-JP503(B)

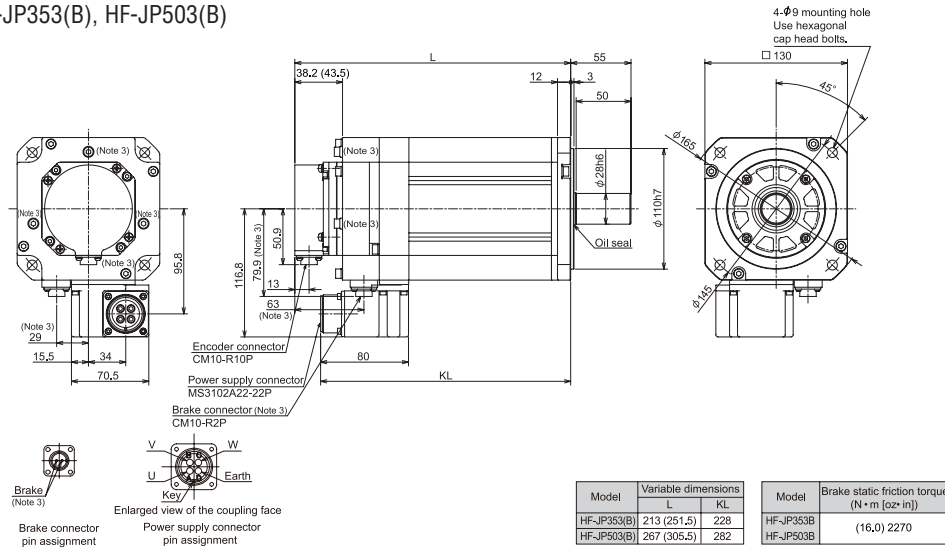

Model	Variable dimensions		Model	Brake static friction torque (N·m [oz·in])
	L	KL		
HF-JP353(B)	213 (251.5)	228	HF-JP353B	(16.0) 2270
HF-JP503(B)	267 (305.5)	282	HF-JP503B	

Notes:

1. Use a friction coupling to fasten a load.
2. Dimensions inside () are for the models with an electromagnetic brake.
3. Only for the models with an electromagnetic brake. The electromagnetic brake terminals do not have polarity.
4. For dimensions where there is no tolerance listed, use general tolerance.

HF-JP11K1M(B), HF-JP15K1M(B), HF-JP11K1M4(B), HF-JP15K1M4(B)

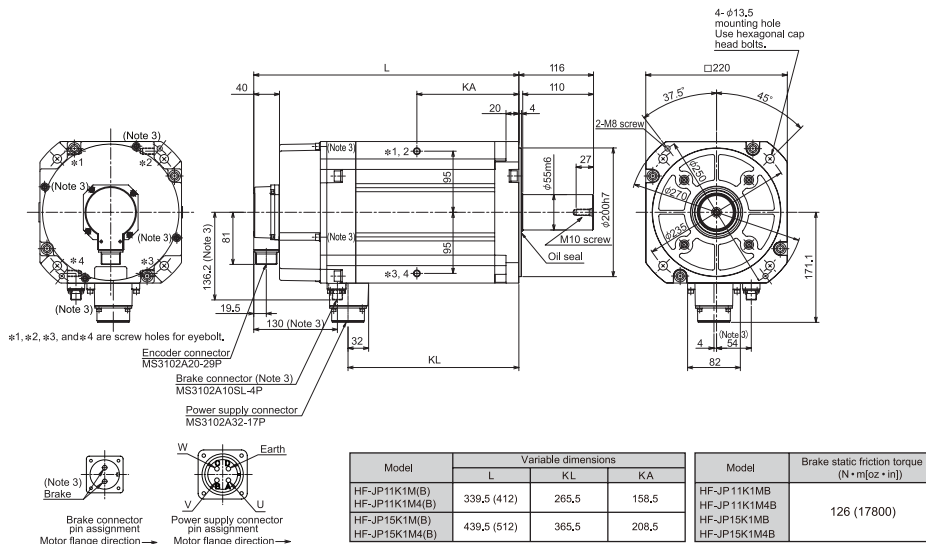

Model	Variable dimensions			Model	Brake static friction torque (N·m [oz·in])
	L	KL	KA		
HF-JP11K1M(B)	339.5 (412)	265.5	156.5	HF-JP11K1MB	126 (17800)
HF-JP11K1M4(B)				HF-JP11K1M4B	
HF-JP15K1M(B)	439.5 (512)	365.5	208.5	HF-JP15K1MB	
HF-JP15K1M4(B)				HF-JP15K1M4B	

HF-JP534(B), HF-JP734(B), HF-JP1034(B), HF-JP1534(B), HF-JP2034(B)

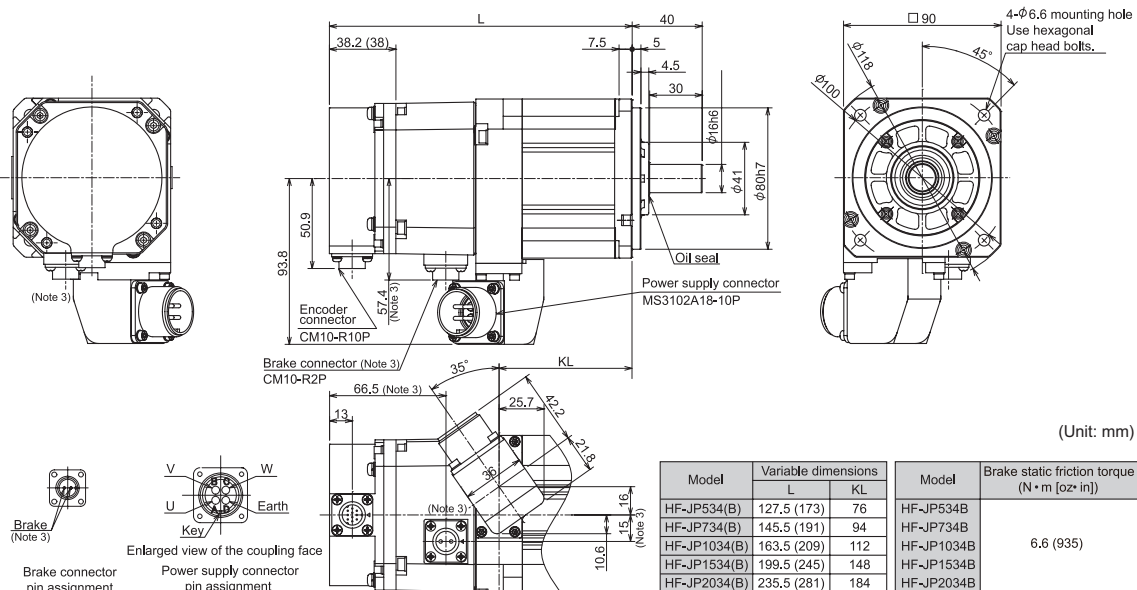

(Unit: mm)

Model	Variable dimensions		Model	Brake static friction torque (N·m [oz·in])
	L	KL		
HF-JP534(B)	127.5 (173)	76	HF-JP534B	6.6 (935)
HF-JP734(B)	145.5 (191)	94	HF-JP734B	
HF-JP1034(B)	163.5 (209)	112	HF-JP1034B	
HF-JP1534(B)	199.5 (245)	148	HF-JP1534B	
HF-JP2034(B)	235.5 (281)	184	HF-JP2034B	

HF-JP3534(B), HF-JP5034(B)

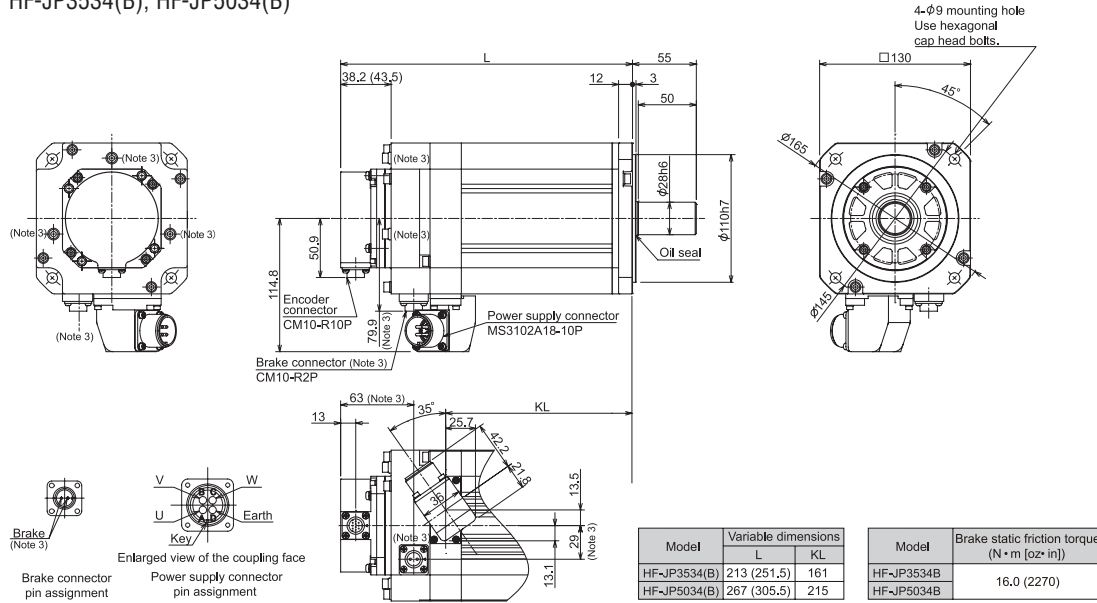

HC-LP Series

HC-LP52(B) to HC-LP152(B)

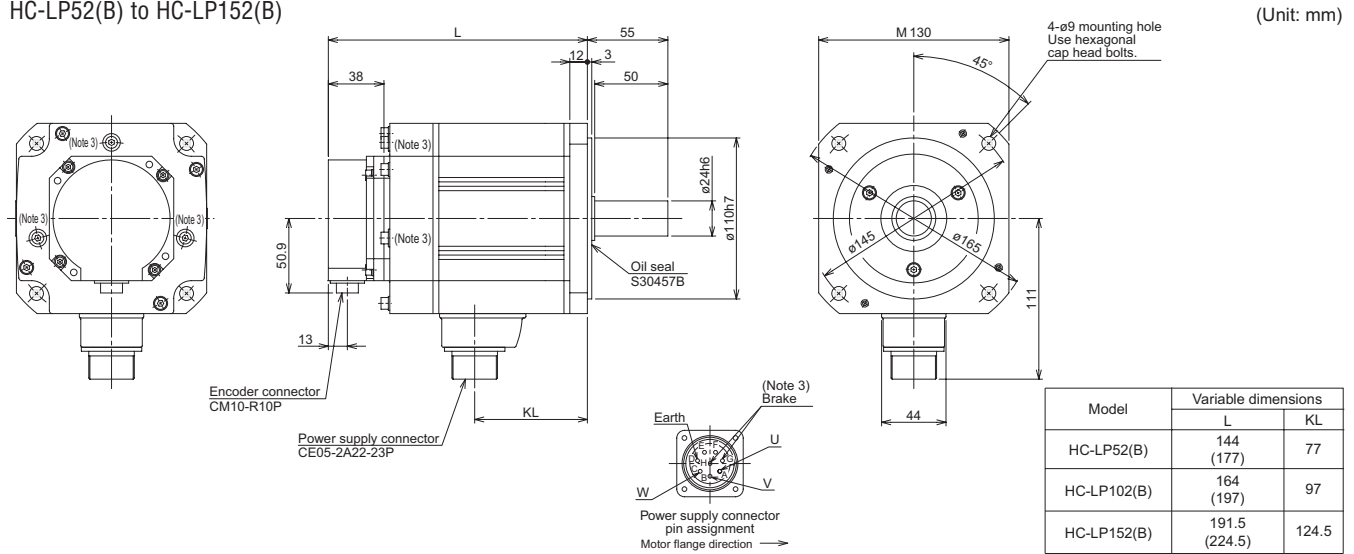

HC-LP202(B), HC-LP302(B)

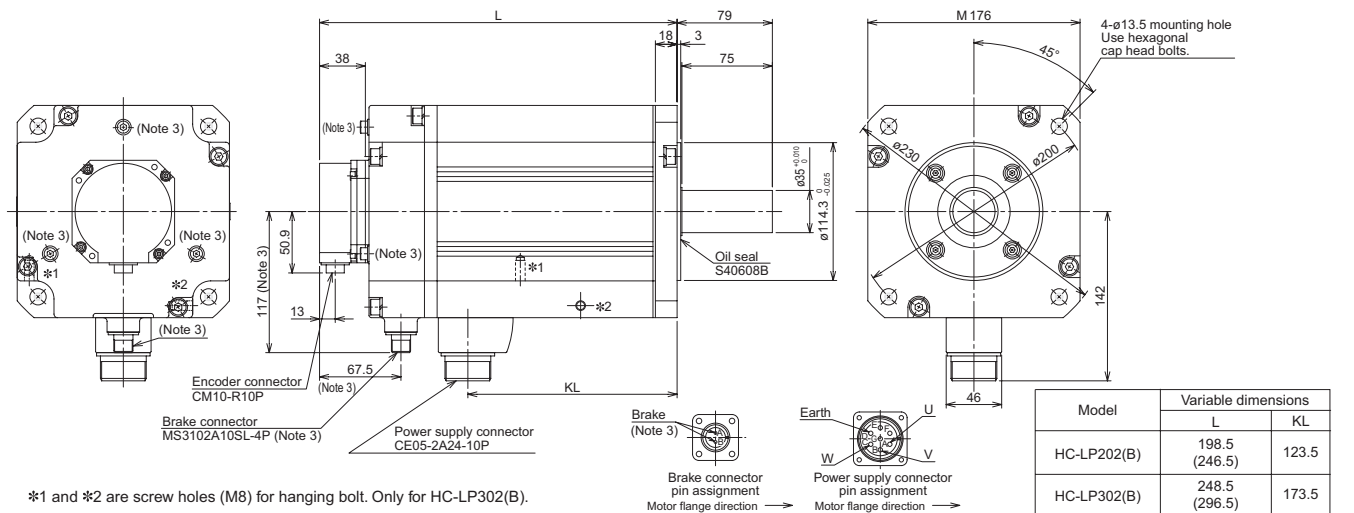

*1 and *2 are screw holes (M8) for hanging bolt. Only for HC-LP302(B).

Notes:

1. Use a friction coupling to fasten a load.
2. Dimensions inside () are for the models with an electromagnetic brake.
3. Only for the models with an electromagnetic brake. The electromagnetic brake terminals do not have polarity.
4. For dimensions where there is no tolerance listed, use general tolerance.

HC-RP Series

HC-RP103(B) to HC-RP203(B)

(Unit: mm)

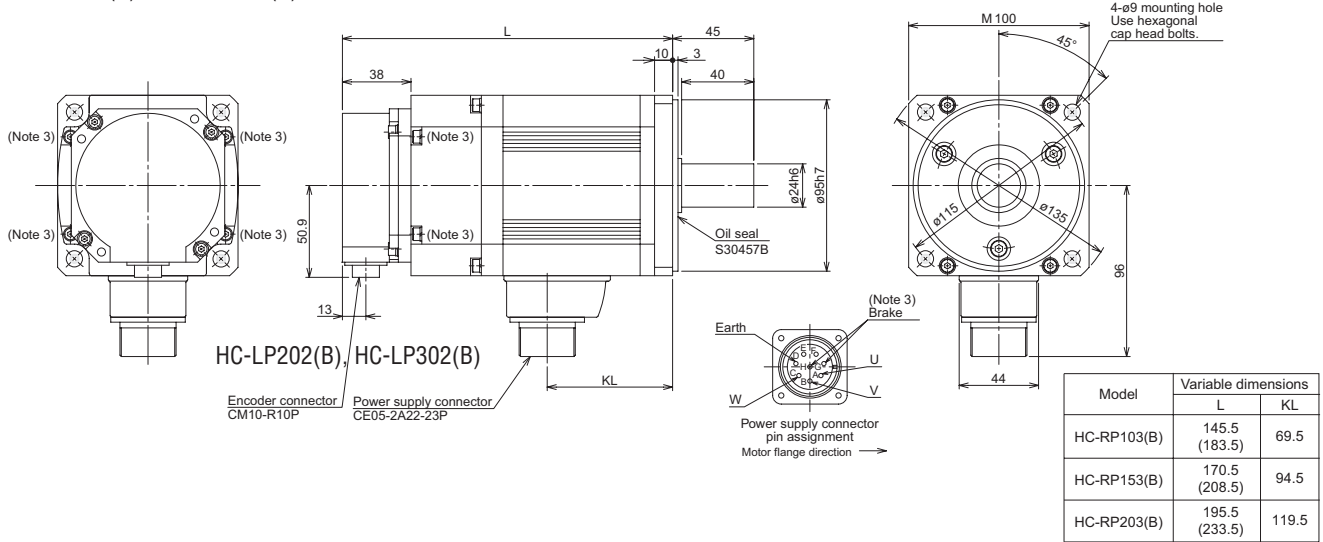

HC-RP353(B), HC-RP503(B)

(Unit: mm)

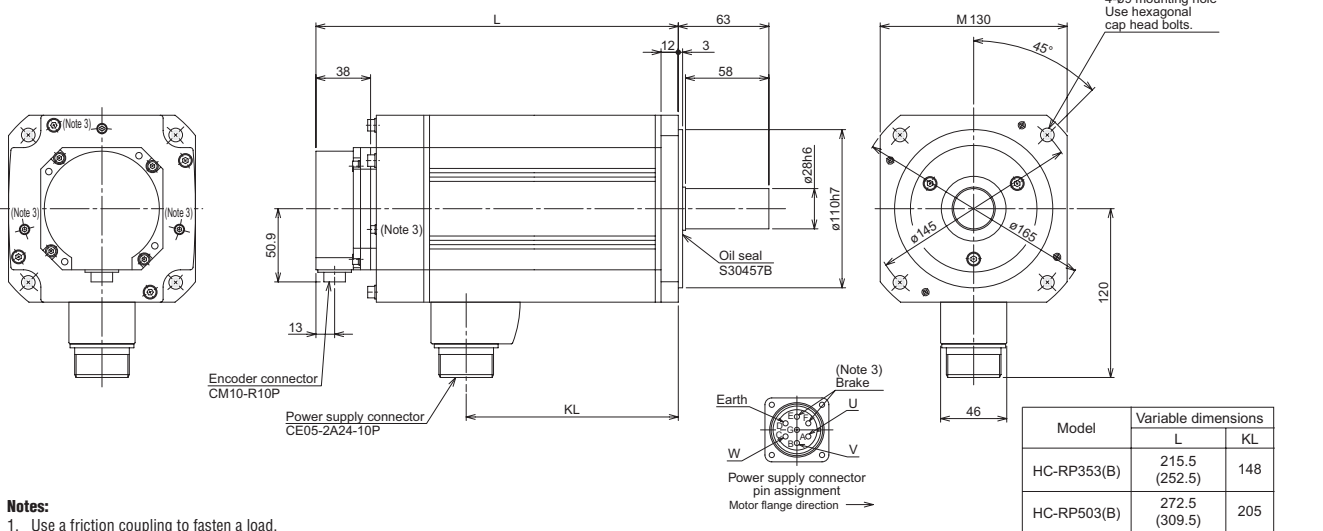

Notes:

1. Use a friction coupling to fasten a load.
2. Dimensions inside () are for the models with an electromagnetic brake.
3. Only for the models with an electromagnetic brake. The electromagnetic brake terminals do not have the polarity.
4. For dimensions where there is no tolerance listed, use general tolerance.

HC-UP Series

HC-UP72(B), HC-UP152(B)

(Unit: mm)

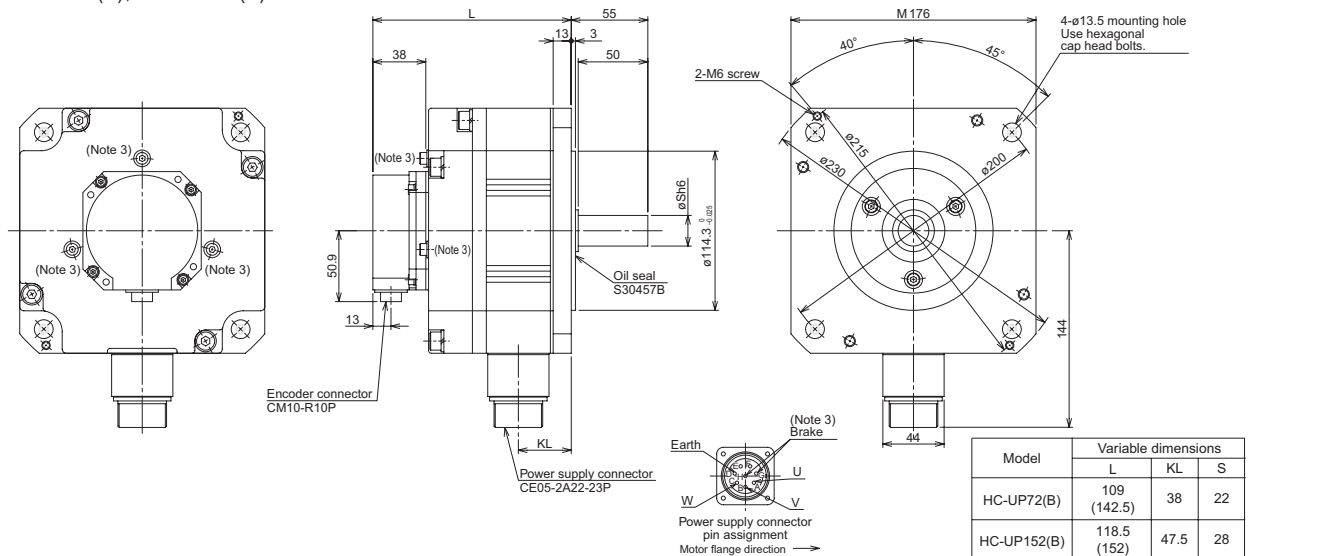

HC-UP202(B) to HC-UP502(B)

(Unit: mm)

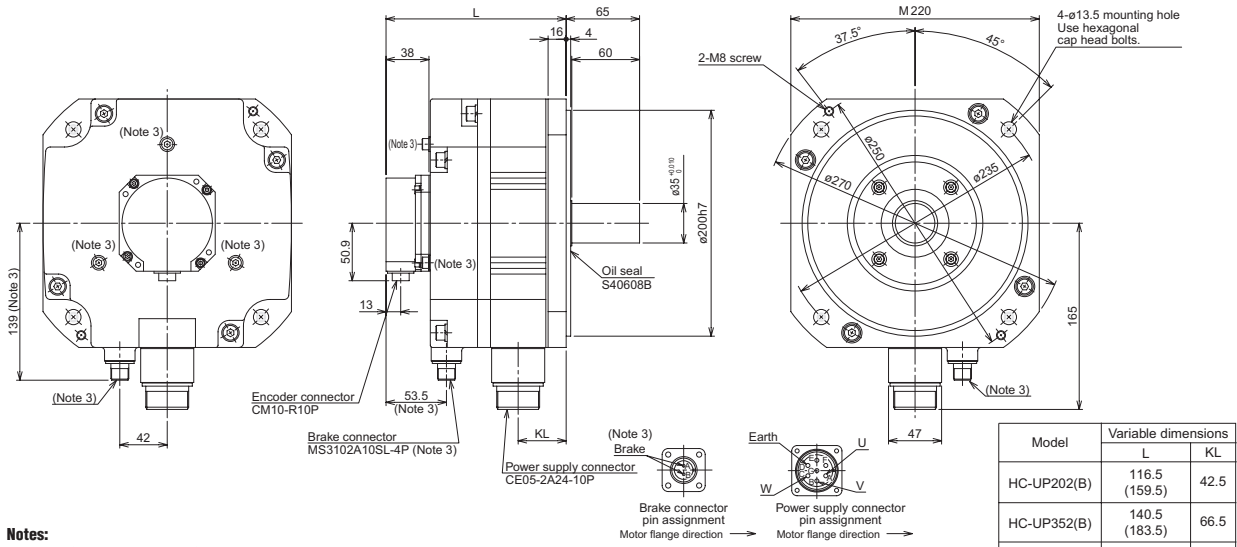

Notes:

1. Use a friction coupling to fasten a load.
2. Dimensions inside () are for the models with an electromagnetic brake.
3. Only for the models with an electromagnetic brake. The electromagnetic brake terminals do not have the polarity.
4. For dimensions where there is no tolerance listed, use general tolerance.

HA-LP Series

HA-LP502

(Unit: mm)

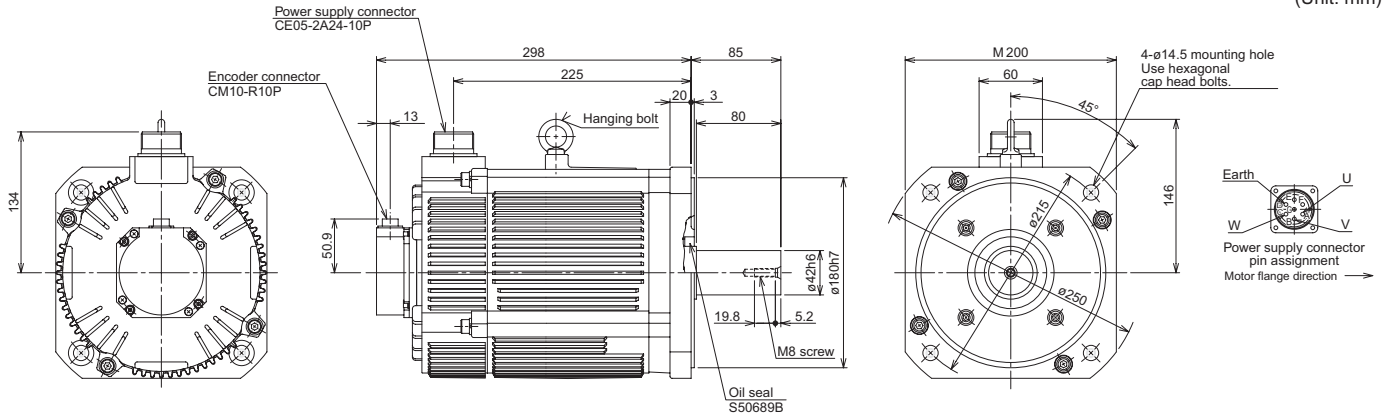

Notes:

1. Use a friction coupling to fasten a load.
2. For dimensions where there is no tolerance listed, use general tolerance.

HA-LP702

(Unit: mm)

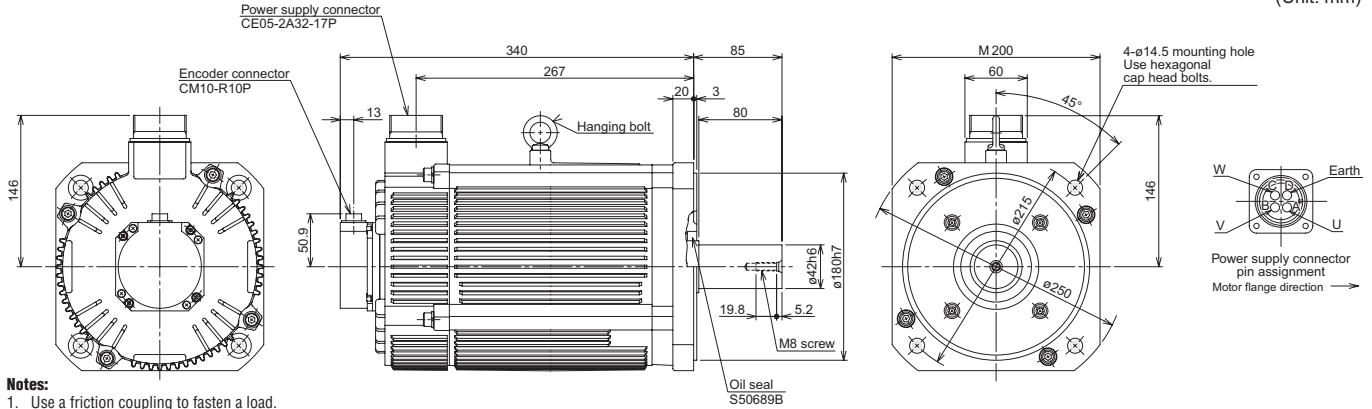

Notes:

1. Use a friction coupling to fasten a load.
2. For dimensions where there is no tolerance listed, use general tolerance.

HA-LP601(B), HA-LP6014(B)
 HA-LP701M(B), HA-LP701M4(B)
 HA-LP11K2(B), HA-LP11K24(B)

(Unit: mm)

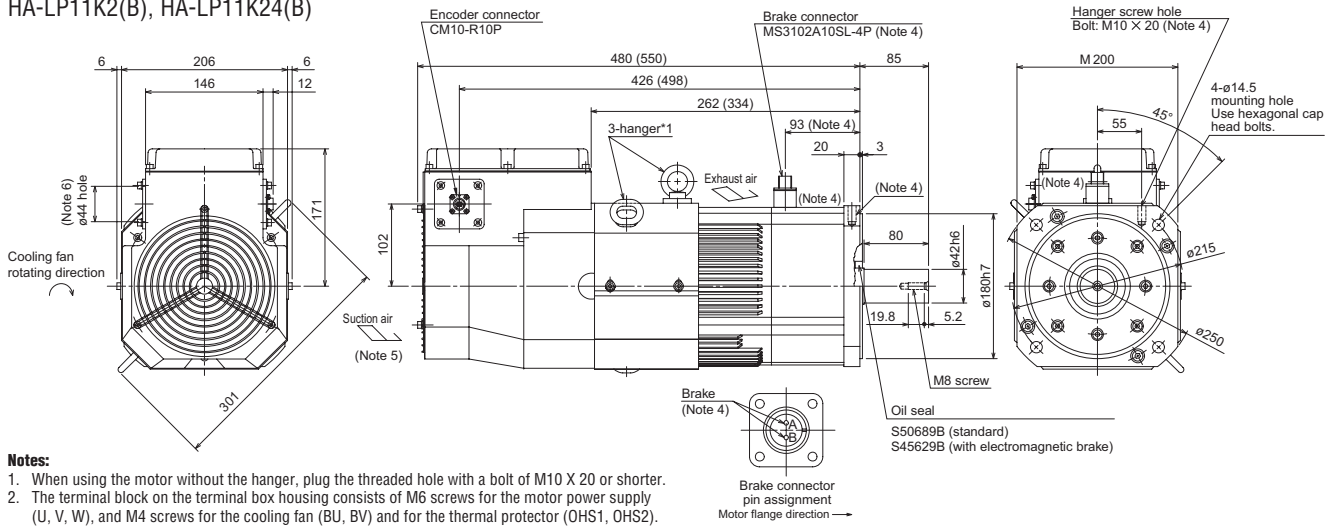

HA-LP801(B), HA-LP12K1(B), HA-LP8014(B) (*7), HA-LP12K14(B)
 HA-LP11K1M(B), HA-LP15K1M(B), HA-LP11K1M4(B) (*7), HA-LP15K1M4(B)
 HA-LP15K2(B), HA-LP22K2(B), HA-LP15K24(B), HA-LP22K24(B)

(Unit: mm)

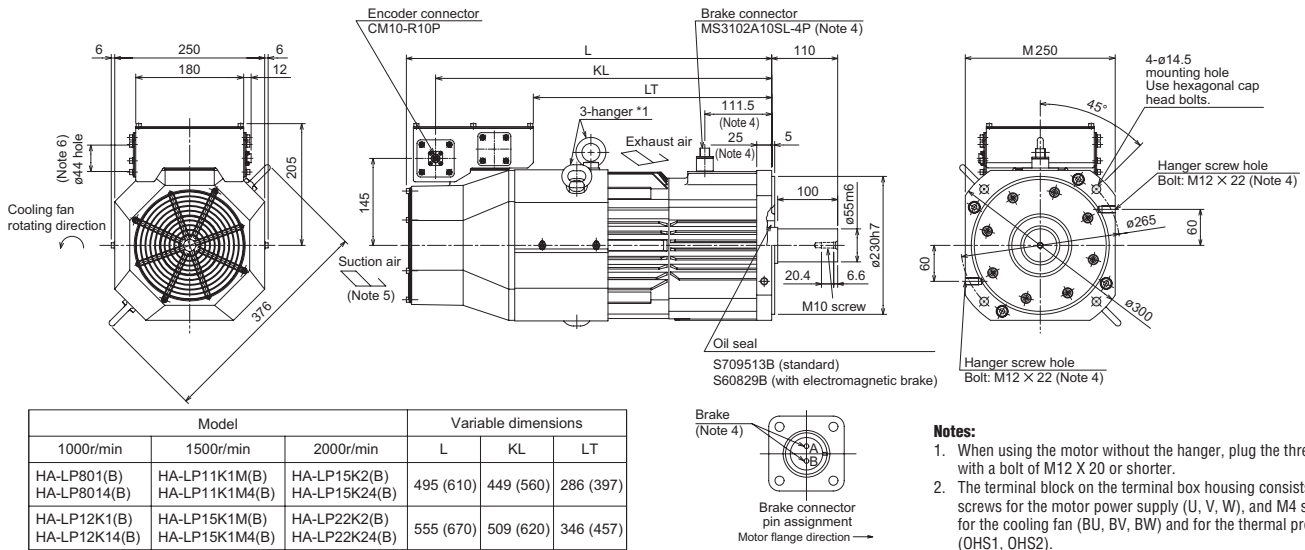

Notes:

- Use a friction coupling to fasten a load.
- For dimensions where there is no tolerance listed, use general tolerance.
- Dimensions inside () are for the models with an electromagnetic brake.
- Only for the models with an electromagnetic brake. The electromagnetic brake terminals do not have polarity.
- Leave a clearance of at least 100mm between the motor's suction side and wall.
- Make sure that oil, water and dust, etc., will not enter the motor from the lead-in hole.
- Contact your dealer for the delivery schedule or the compatible servo amplifier's software version.

HA-LP15K1, HA-LP20K1, HA-LP15K14, HA-LP20K14 (*7)
 HA-LP22K1M, HA-LP22K1M4 (*7), HA-LP30K1M4
 HA-LP30K24, HA-LP37K24

(Unit: mm)

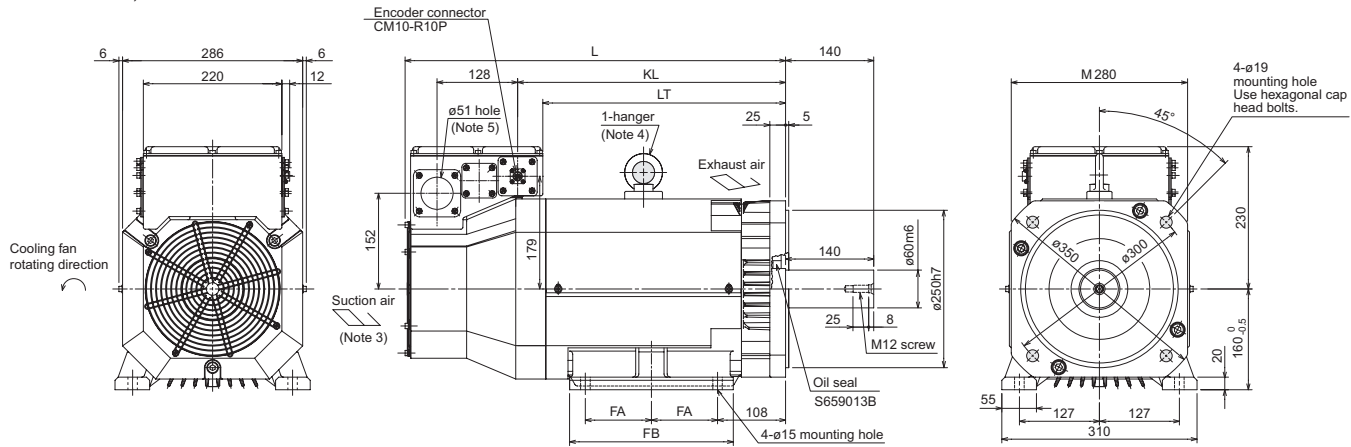

* The terminal block on the terminal box housing consists of M8 screws for the motor power supply (U, V, W), and M4 screws for the cooling fan (BU, BV, BW) and for the thermal protector (OHS1, OHS2).

Model			Variable dimensions				
1000r/min	1500r/min	2000r/min	L	KL	LT	FA	FB
HA-LP15K1 HA-LP15K14	HA-LP22K1M HA-LP22K1M4	HA-LP30K24	605	426	386	105	260
HA-LP20K1 HA-LP20K14	HA-LP30K1M4	HA-LP37K24	650	471	431	127	304

HA-LP25K1, HA-LP30K1, HA-LP25K14, HA-LP30K14
 HA-LP37K1M, HA-LP37K1M4, HA-LP45K1M4
 HA-LP45K24, HA-LP55K24

(Unit: mm)

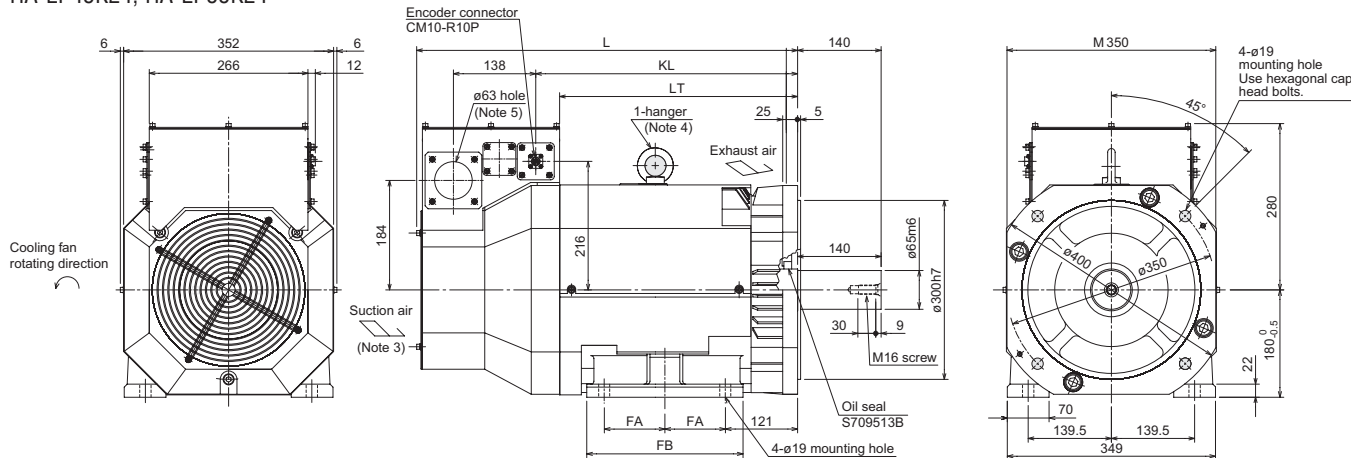

* The terminal block on the terminal box housing consists of M10 screws for the motor power supply (U, V, W), and M4 screws for the cooling fan (BU, BV, BW) and for the thermal protector (OHS1, OHS2).

Model			Variable dimensions				
1000r/min	1500r/min	2000r/min	L	LT	KL	FA	FB
HA-LP25K1 HA-LP25K14	HA-LP37K1M HA-LP37K1M4	HA-LP45K24	640	399	439	101.5	262
HA-LP30K1 HA-LP30K14	HA-LP45K1M4	HA-LP55K24	685	444	484	120.5	300

Notes:

1. Use a friction coupling to fasten a load.
2. For dimensions where there is no tolerance listed, use general tolerance.
3. Leave a clearance of at least 150mm between the motor's suction side and wall.
4. When using the motor without the hanger, plug the threaded hole with a bolt of M16 X 20 or shorter.
5. Make sure that oil, water and dust, etc., will not enter the motor from the lead-in hole.
6. When mounting the motor with the shaft horizontal, fix the motor either with the feet or the flange, keeping the feet downward. Note that when fixing the motor with the flange, also fix the feet to support the motor.
7. Contact your dealer for the delivery schedule or the compatible servo amplifier's software version.

HA-LP30K1M
HA-LP30K2, HA-LP37K2

(Unit: mm)

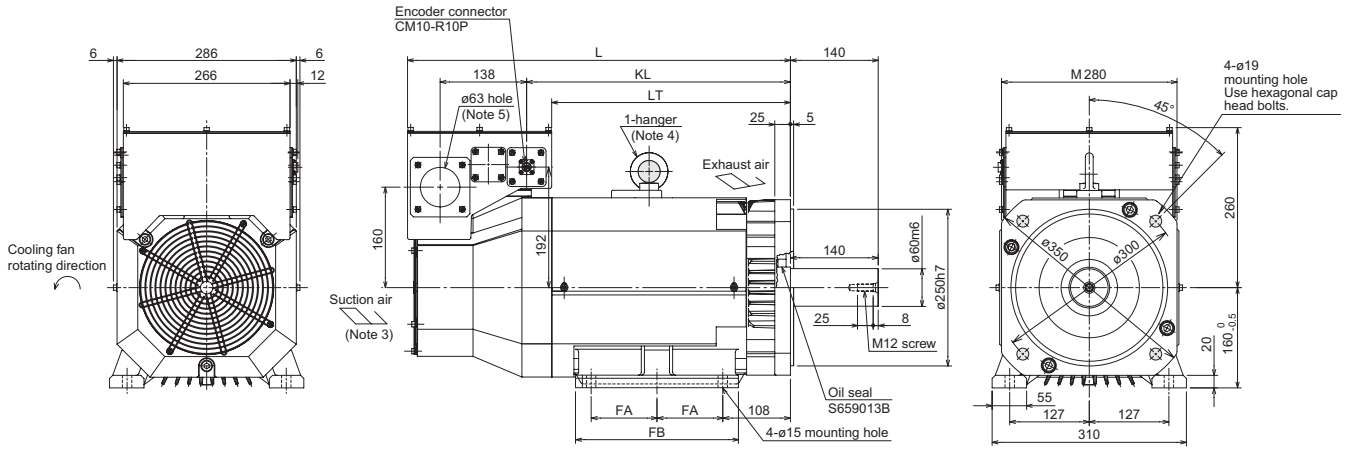

* The terminal block on the terminal box housing consists of M10 screws for the motor power supply (U, V, W), and M4 screws for the cooling fan (BU, BV, BW) and for the thermal protector (OHS1, OHS2).

Model		Variable dimensions				
1500r/min	2000r/min	L	LT	KL	FA	FB
—	HA-LP30K2	615	381	421	105	260
HA-LP30K1M	HA-LP37K2	660	426	466	127	304

HA-LP37K1, HA-LP37K14
HA-LP50K1M4

(Unit: mm)

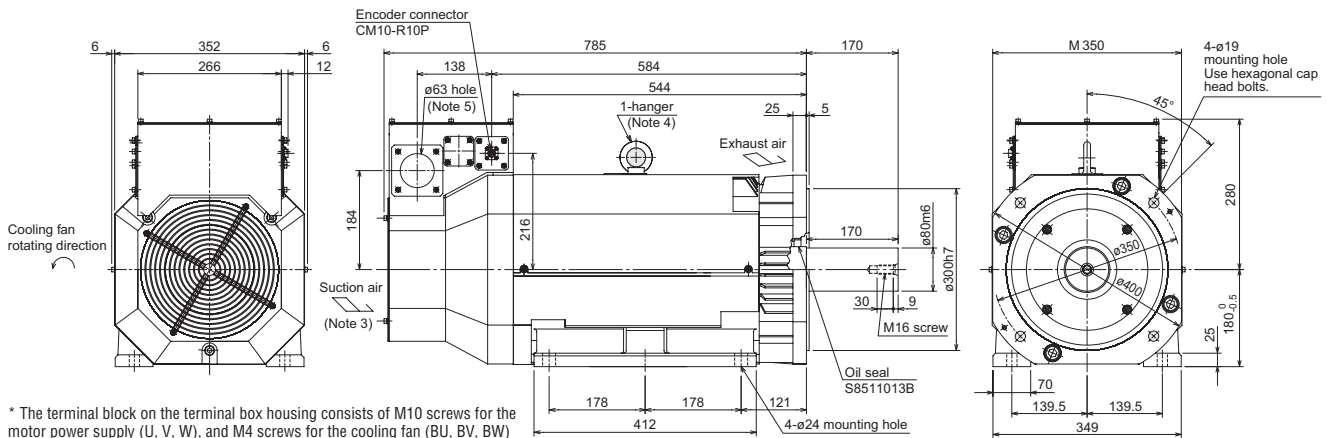

* The terminal block on the terminal box housing consists of M10 screws for the motor power supply (U, V, W), and M4 screws for the cooling fan (BU, BV, BW) and for the thermal protector (OHS1, OHS2).

Notes:

1. Use a friction coupling to fasten a load.
2. For dimensions where there is no tolerance listed, use general tolerance.
3. Leave a clearance of at least 150mm between the motor's suction side and wall.
4. When using the motor without the hanger, plug the threaded hole with a bolt of M16 X 20 or shorter.
5. Make sure that oil, water and dust, etc., will not enter the motor from the lead-in hole.
6. When mounting the motor with the shaft horizontal, fix the motor either with the feet or the flange, keeping the feet downward. Note that when fixing the motor with the flange, also fix the feet to support the motor.

MR-J3 Linear Servomotors and Amplifiers

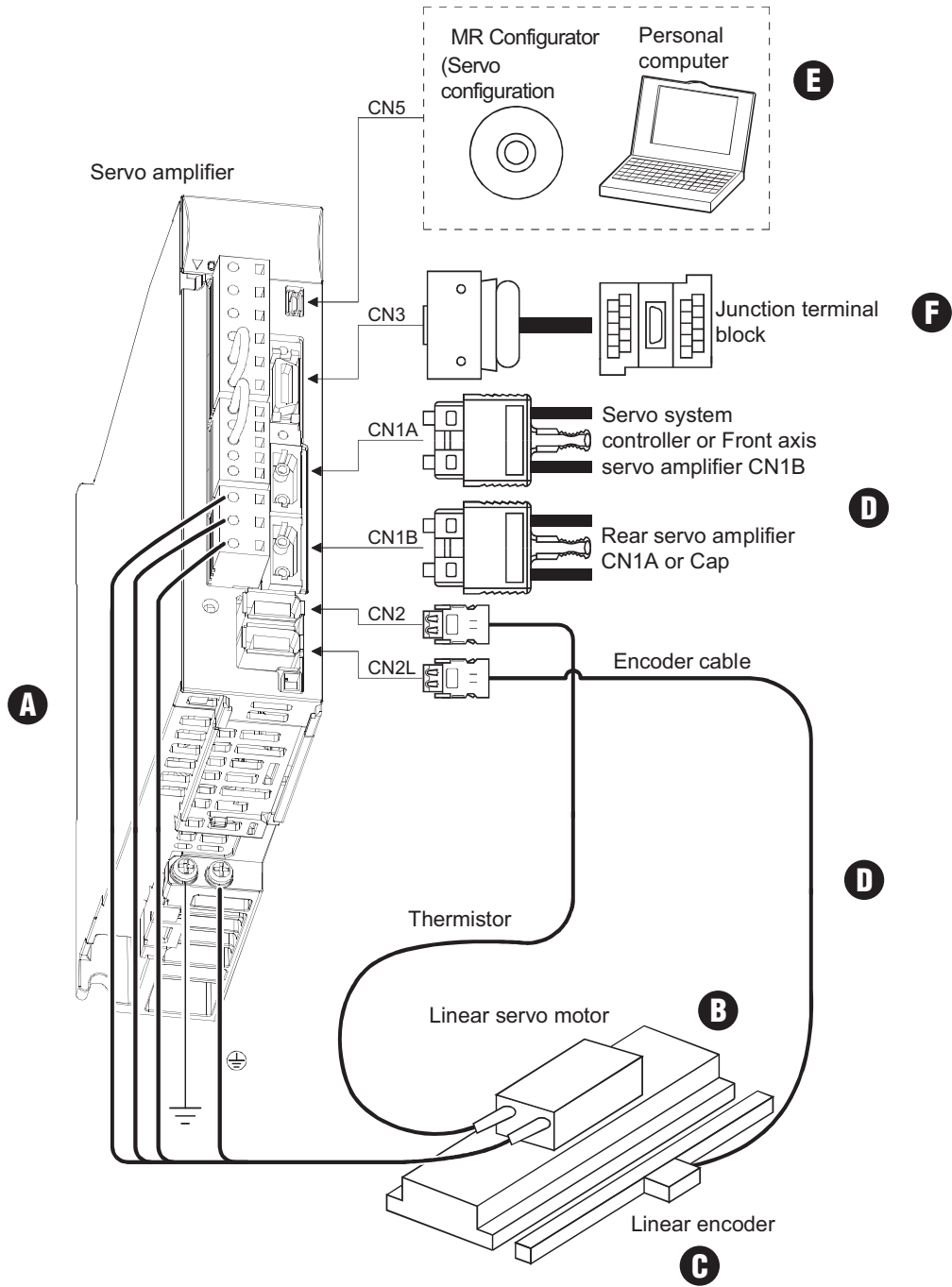

A. Amplifier.....	313
B. Motor	315
C. Linear Encoder (Customer Supplied)	321
D. Cables and Connectors.....	322
E. Software and Manuals.....	324
F. Optional Accessories.....	324

A MR-J3 Linear Amplifiers (*1)

Amplifier Selection

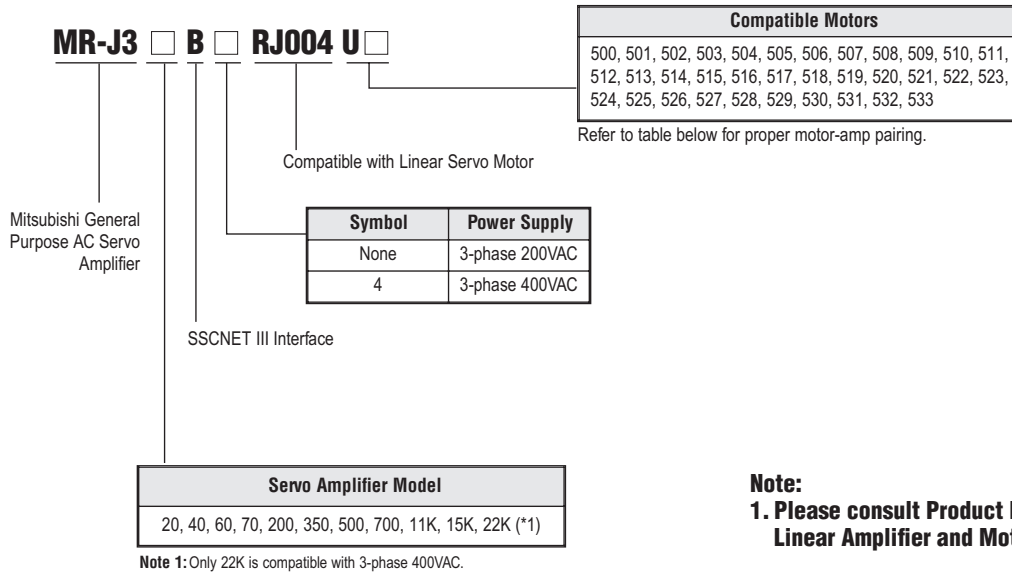

Note:
1. Please consult Product Marketing for all Linear Amplifier and Motor opportunities.

Combination of Linear Servo Motor and Servo Amplifier

Linear Servo Motor			Servo Amplifier	
Primary Side (Coil)	Stock Item	Secondary Side (Magnet)		
LM-H2 Series	LM-H2P1A-06M-4SS0	-	LM-H2S10-288-4SS0, LM-H2S10-384-4SS0, LM-H2S10-480-4SS0, LM-H2S10-768-4SS0	MR-J340BRJ004U500
	LM-H2P2A-12M-1SS0	-		MR-J340BRJ004U501
	LM-H2P2B-24M-1SS0	-		MR-J370BRJ004U502
	LM-H2P2C-36M-1SS0	-	LM-H2S20-288-1SS0, LM-H2S20-384-1SS0, LM-H2S20-480-1SS0, LM-H2S20-768-1SS0	MR-J3200BRJ004U503
	LM-H2P2D-48M-1SS0	-		MR-J3200BRJ004U504
	LM-H2P3A-24M-1SS0	-		MR-J370BRJ004U505
	LM-H2P3B-48M-1SS0	-	LM-H2S30-288-1SS0, LM-H2S30-384-1SS0, LM-H2S30-480-1SS0, LM-H2S30-768-1SS0	MR-J3200BRJ004U506
	LM-H2P3C-72M-1SS0	-		MR-J3350BRJ004U507
LM-H2P3D-96M-1SS0	-		MR-J3500BRJ004U508	
LM-F Series	LM-FP2B-06M-1SS0	-	LM-FS20-480-1SS0, LM-FS20-576-1SS0	MR-J3200BRJ004U518 (for self-cooling) MR-J3200BRJ004U519 (for liquid-cooling)
	LM-FP2D-12M-1SS0	-		MR-J3500BRJ004U520 (for self-cooling) MR-J3500BRJ004U521 (for liquid-cooling)
	LM-FP2F-18M-1SS0	-		MR-J3700BRJ004U522 (for self-cooling) MR-J3700BRJ004U523 (for liquid-cooling)
	LM-FP4B-12M-1SS0	-	LM-FS40-480-1SS0, LM-FS40-576-1SS0	MR-J3500BRJ004U524 (for self-cooling) MR-J3500BRJ004U525 (for liquid-cooling)
	LM-FP4D-24M-1SS0	-		MR-J3700BRJ004U526 (for self-cooling) MR-J3700BRJ004U527 (for liquid-cooling)
	LM-FP4F-36M-1SS0	-		MR-J311KBRJ004U528 (for self-cooling) MR-J311KBRJ004U529 (for liquid-cooling)
	LM-FP4H-48M-1SS0	-		MR-J315KBRJ004U530 (for self-cooling) MR-J315KBRJ004U531 (for liquid-cooling)
	LM-FP5H-60M-1SS0	-	LM-FS50-480-1SS0, LM-FS50-576-1SS0	MRJ322KB4RJ004U532 (for self-cooling) (*1) MRJ322KB4RJ004U533 (for liquid-cooling) (*1)
LM-U2 Series	LM-U2PAB-05M-0SS0	-		MR-J320BRJ004U512
	LM-U2PAD-10M-0SS0	-	LM-U2SA0-240-0SS0, LM-U2SA0-300-0SS0, LM-U2SA0-420-0SS0	MR-J340BRJ004U513
	LM-U2PAF-15M-0SS0	-		MR-J340BRJ004U514
	LM-U2PBB-07M-1SS0	-		MR-J320BRJ004U515
	LM-U2PBD-15M-1SS0	-	LM-U2SB0-240-1SS0, LM-U2SB0-300-1SS0, LM-U2SB0-420-1SS0	MR-J360BRJ004U516
	LM-U2PBF-22M-1SS0	-		MR-J370BRJ004U517
	LM-U2P2B-40M-2SS0	-		MR-J3200BRJ004U509
	LM-U2P2C-60M-2SS0	-	LM-U2S20-300-2SS0, LM-U2S20-480-2SS0	MR-J3350BRJ004U510
LM-U2P2D-80M-2SS0	-		MR-J3500BRJ004U511	

Note 1: Servo amplifiers MR-J3-22KB4-RJ004U_ are rated 400VAC. 200VAC class is not available.

Amplifier Specifications

Servo Amplifier Model		20B-RJ004U	40B-RJ004U	60B-RJ004U	70B-RJ004U	200B-RJ004U	350B-RJ004U	500B-RJ004U	700B-RJ004U	11KB-RJ004U	15KB-RJ004U	22KB4-RJ004U	
Main Circuit Power Supply	Voltage/Frequency (*1)	3-phase 200 to 230VAC 50/60Hz or 1-phase 200 to 230VAC 50/60Hz				3-phase 200 to 230VAC 50/60Hz						3-phase 380 to 480VAC 50/60/60Hz	
	Permissible Voltage Fluctuation	For 3-phase 200 to 230VAC: 3-phase 170 to 253VAC For 1-phase 200 to 230VAC: 1-phase 170 to 253VAC				3-phase 170 to 253VAC						3-phase 323 to 528VAC	
	Permissible Frequency Fluctuation	±5% maximum											
Control Circuit Power Supply	Voltage/Frequency	1-phase 200 to 230VAC 50/60Hz										1-phase 380 to 480VAC 50/60Hz	
	Permissible Voltage Fluctuation	1-phase 170 to 253VAC										1-phase 323 to 528VAC	
	Permissible Frequency Fluctuation	±5% maximum											
	Power Consumption (W)	30					45						
Interface Power Supply		24VDC ±10% (required current capacity: 150mA (*3))											
Linear Encoder Interface	Serial Interface		Mitsubishi high-speed serial communicationLinear										
	Pulse Train Interface	Input Signal	ABZ phase differential input signal										
		Minimum Phase Difference	200ns										
Regenerative Resistor / Tolerable Regenerative Power (W) (*4, *5)	Built-In Regenerative Resistor	10	10	10	20	100	100	130	170	-	-	-	
	External Regenerative Resistor (*6)	-	-	-	-	-	-	-	-	500 (800)	850 (1300)	850 (1300)	
Control System		Sine-wave PWM control/current control system											
Dynamic Brake		Built-in								External option			
Safety Features		Overcurrent shutdown, regeneration overvoltage shutdown, overload shutdown (electronic thermal), servo motor overheat protection, encoder fault protection, regeneration fault protection, undervoltage/sudden power outage protection, overspeed protection, excess error protection											
Structure		Self-cooling open (IP00)					Fan cooling open (IP00)						
Environment	Ambient Temperature (*2)	0 to 55°C (32 to 131°F) (non-freezing), storage: -20 to 65°C (-4 to 149°F) (non-freezing)											
	Ambient Humidity	90% RH maximum (non condensing), storage: 90% RH maximum (non condensing)											
	Atmosphere	Indoors (no direct sunlight); no corrosive gas, inflammable gas, oil mist or dust											
	Elevation	1000m or less above sea level											
Vibration		5.9m/s ² maximum											
Mass kg (lb)		0.8 (1.8)	1.0 (2.2)	1.0 (2.2)	1.4 (3.1)	2.3 (5.1)	2.3 (5.1)	4.6 (10)	6.2 (14)	18 (40)	18 (40)	19 (42)	

Notes:

- Rated thrust and speed of a linear servo motor are applicable when the servo amplifier, combined with the linear servo motor, is operated within the specified power supply voltage and frequency. Thrust drops when the power supply voltage is below the specified value.
- The MR-J3-350B-RJ004U or smaller servo amplifier can be installed closely. In this case, keep the ambient temperature within 0 to 45°C (32 to 113°F), or use them with 75% or less of the effective load rate.
- 150mA is the value when all of the input/output points are used. The current capacity can be stepped down according to the number of input/output points in use.
- Optimal regenerative resistor varies for each system.
- Refer to the section "Selecting linear servo 3. Selecting optional regenerative unit" in this catalog for the tolerable regenerative power (W).
- The value applies when the external regenerative resistors, GRZG400-MW, (standard accessory) are used with cooling fans (2 units of 92x92mm, minimum air flow: 1.0m³/min). Note that change in the parameter No. PA02 is required.

Electrical wires, circuit breakers, magnetic contactors (example of selection)

The following are examples of wire sizes when 600V polyvinyl chloride insulated wires with a length of 30m are used.

Servo Amplifier	Circuit Breaker	Magnetic Contactor	Electrical Wire Size (mm ²)				
			L1, L2, L3	L11, L21	U, V, W	P, C	THM1, THM2
MR-J3-20B-RJ004U	30A frame 5A	S-N10	2 (AWG14)	1.25 (AWG16)	1.25 (AWG16)	2 (AWG14)	0.2 (AWG24)
MR-J3-40B-RJ004U	30A frame 10A						
MR-J3-60B-RJ004U	30A frame 15A						
MR-J3-70B-RJ004U							
MR-J3-200B-RJ004U	30A frame 20A	S-N18	3.5 (AWG12)	1.25 (AWG16)	2 (AWG14)	3.5 (AWG12)	0.2 (AWG24)
MR-J3-350B-RJ004U	30A frame 30A	S-N20					
MR-J3-500B-RJ004U (*1)	50A frame 50A	S-N35	5.5 (AWG10)	1.25 (AWG16)	5.5 (AWG10)	5.5 (AWG10)	0.2 (AWG24)
MR-J3-700B-RJ004U (*1)	100A frame 75A	S-N50	8 (AWG8)				
MR-J3-11KB-RJ004U (*1)	100A frame 100A	S-N65	14 (AWG6)	1.25 (AWG16)	22 (AWG4)	3.5 (AWG12)	0.2 (AWG24)
MR-J3-15KB-RJ004U (*1)	225A frame 125A	S-N95	22 (AWG4)				
MR-J3-22KB4-RJ004U (*1)	225A frame 125A	S-N65	14 (AWG6)	1.25 (AWG16)	22 (AWG4)	5.5 (AWG10)	0.2 (AWG24)

Note:

- When connecting the wires to the terminal screws, be sure to use the screws attached to the terminal blocks.

B MR-J3 Linear Servomotors

LM-H2 Linear Servomotor Selection

LM-H2P □ □ - □ M - □ (Primary side: Coil)

Symbol	Maximum Speed
M	2m/s

Symbol	Rated Thrust
06	60N
12	120N
24	240N
36	360N
48	480N
72	720N
96	960N

Symbol	Length (Nominal Dimension)
A	128 mm
B	224 mm
C	320 mm
D	416 mm

Symbol	Width (Nominal Dimension)
1	50 mm
2	70 mm
3	110 mm

Symbol	Motor Model
4SS0	LM-H2P1A-06M
	LM-H2P2A-12M
	LM-H2P2B-24M
1SS0	LM-H2P2C-36M
	LM-H2P2D-48M
	LM-H2P3A-24M
	LM-H2P3B-48M
	LM-H2P3C-72M
	LM-H2P3D-96M

LM-H2S □ 0 - □ - □ (Secondary side: Magnet)

Symbol	Motor Model
4SS0	LM-H2P10-288
	LM-H2P10-384
	LM-H2P10-480
	LM-H2P10-768
1SS0	LM-H2P20-288
	LM-H2P20-384
	LM-H2P20-480
	LM-H2P20-768
	LM-H2P30-288
	LM-H2P30-384
	LM-H2P30-480
	LM-H2P30-768

Symbol	Length (Nominal Dimension)
288	288 mm
384	384 mm
480	480 mm
768	768 mm

Symbol	Width (Nominal Dimension)
1	42 mm
2	65 mm
3	105 mm

LM-F Linear Servomotor Selection

LM-FP □ □ - □ M - 1SS0

(Primary side: Coil)

Symbol	Maximum Speed
M	2m/s

Symbol	Length (Nominal Dimension)
B	290 mm
D	530 mm
F	770 mm
H	1010 mm

Symbol	Width (Nominal Dimension)
2	120 mm
4	200 mm
5	240 mm

Symbol	Rated Thrust	
	Self-Cooling	Liquid Cooling
06	300N	600N
12	600N	1200N
18	900N	1800N
24	1200N	2400N
36	1800N	3600N
48	2400N	4800N
60	3000N	6000N

LM-FS □ 0 - □ - 1SS0

(Secondary side: Magnet)

Symbol	Width (Nominal Dimension)
2	120 mm
4	200 mm
5	240 mm

Symbol	Length (Nominal Dimension)
480	480 mm
576	576 mm

LM-U2 (Medium Thrust) Linear Servomotor Selection

LM-U2P □ □ - □ □ **M** - □ □ (Primary side: Coil)

Symbol	Maximum Speed
M	2m/s

Symbol	Rated Thrust
05	50N
07	75N
10	100N
15	150N
22	225N

Symbol	Length (Nominal Dimension)
B	130 mm
D	250 mm
F	370 mm

Symbol	Width (Nominal Dimension)
A	66.5 mm
B	86.5 mm

Symbol	Motor Model
0SS0	LM-U2PAB-05M
	LM-U2PAD-10M
	LM-U2PAF-15M
1SS0	LM-U2PBB-07M
	LM-U2PBD-15M
	LM-U2PBF-22M

LM-U2S □ □ **0** - □ □ (Secondary side: Magnet)

Symbol	Motor Model
0SS0	LM-U2SA0-240
	LM-U2SA0-300
	LM-U2SA0-420
1SS0	LM-U2SB0-240
	LM-U2SB0-300
	LM-U2SB0-420

Symbol	Length (Nominal Dimension)
240	240 mm
300	300 mm
420	420 mm

Symbol	Width (Nominal Dimension)
A	62 mm
B	82 mm

LM-U2 (Large Thrust) Linear Servomotor Selection

LM-U2P2 □ □ - □ □ **M** - □ □ (Primary side: Coil)

Symbol	Maximum Speed
M	2m/s

Symbol	Rated Thrust
40	400N
60	600N
80	800N

Symbol	Length (Nominal Dimension)
B	286 mm
C	406 mm
D	526 mm

Symbol	Motor Model
2SS0	LM-U2P2B-40M
	LM-U2P2C-60M
	LM-U2P2D-80M

LM-U2S20 - □ □ - □ □ (Secondary side: Magnet)

Symbol	Length (Nominal Dimension)
300	300 mm
480	480 mm

Symbol	Motor Model
2SS0	LM-U2S20-300
	LM-U2S20-480

Servomotor Types

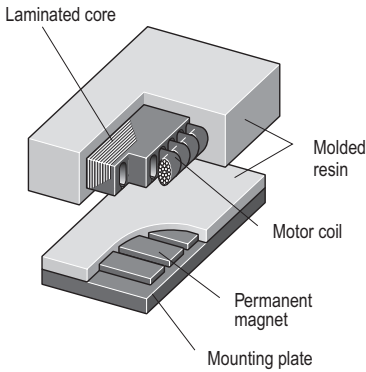
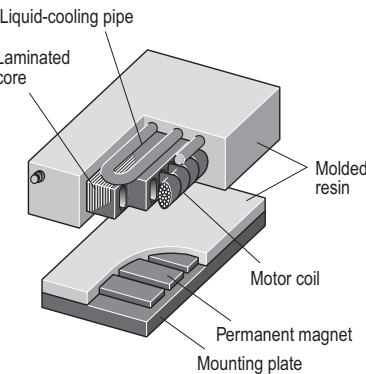
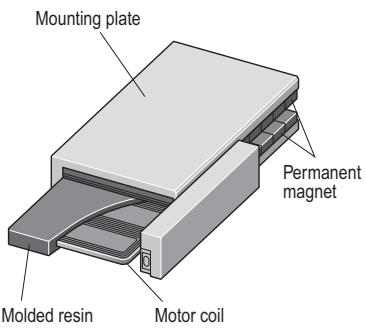
Motor Series		Thrust Range (N)			Features
Core Type	LM-H2 Series 	100	1000	10000	Structure <ul style="list-style-type: none"> The motor consists of the primary side (laminated core + motor coil) and the secondary side (permanent magnets + mounting plate). The primary side has slots on the laminated core. The motor coil is wound on this laminated core, and the entire section is molded by resin. The secondary side has flat permanent magnets positioned and fixed on the mounting plate. The entire section is molded by resin.
	LM-F Series 	300	1800	18000	Structure <ul style="list-style-type: none"> The basic structure is the same as the LM-H2 series. However, LM-F series has a liquid-cooling pipe in the primary side to suppress heat generation.
	LM-U2 Series 	150	3200		Structure <ul style="list-style-type: none"> The motor consists of the primary side (motor coil) and the secondary side (permanent magnets + mounting plate). The primary side does not have a laminated core. The motor coil is accurately positioned on the base and molded by resin. On the secondary side, permanent magnets are accurately positioned and fixed to face each other in a U-shaped like mounting plate.
Coreless Type		60	960		Applications <ul style="list-style-type: none"> Semiconductor mounting system Wafer cleaning system LCD assembly system (multi-head use)
		600	6000		Applications <ul style="list-style-type: none"> NC machine tools Material handling
		50	800		Applications <ul style="list-style-type: none"> Screen printing system Scanning exposure system Inspection system

LM-H2 Linear Motor Specifications

Linear Servo Motor Model LM-H2	P1A-06M-4SS0	P2A-12M-1SS0	P2B-24M-1SS0	P2C-36M-1SS0	P2D-48M-1SS0	P3A-24M-1SS0	P3B-48M-1SS0	P3C-72M-1SS0	P3D-96M-1SS0	
Compatible Amplifier Model MR-J3-	40B-RJ004U500	40B-RJ004U501	70B-RJ004U502	200B-RJ004U503	200B-RJ004U504	70B-RJ004U505	200B-RJ004U506	350B-RJ004U507	500B-RJ004U508	
Power Facility Capacity (kVA)	0.9	0.9	1.3	3.5	3.5	1.3	3.5	5.5	7.5	
Cooling Method	Self-cooling									
Thrust	Continuous (N)	60	120	240	360	480	240	480	720	960
	Maximum (N)	150	300	600	900	1200	600	1200	1800	2400
Maximum Speed (m/s) (*1)	2.0									
Magnetic Attraction Force (N)	500	1000	1900	2700	3500	2000	3700	5300	7000	
Mass kg (lb)	Primary Side (Coil)	0.9 (2.0)	1.4 (3.1)	2.5 (5.6)	3.6 (8.0)	4.7 (11)	2.4 (5.3)	4.3 (9.5)	6.2 (14)	8.1 (18)
	Secondary Side (Magnet)	288mm / piece: 0.6 (1.4) 384mm / piece: 0.8 (1.8) 480mm / piece: 1.0 (2.2) 768mm / piece: 1.6 (3.6)	288mm / piece: 1.1 (2.5) 384mm / piece: 1.4 (3.1) 480mm / piece: 1.8 (4.0) 768mm / piece: 2.9 (6.4)				288mm / piece: 3.2 (7.1) 384mm / piece: 4.3 (9.5) 480mm / piece: 5.3 (12) 768mm / piece: 8.5 (19)			
Secondary Side Model LM-H2	S10_-4SS0	S20_-1SS0				S30_-1SS0				
Recommended Load / Motor Mass Ratio	Maximum of 30 times the mass of the linear servo motor's primary side									
Structure	Open (protection level: IP00)									
Environment	Ambient Temperature	0 to 40°C (32 to 104°F) (non-freezing), storage: -15 to 70°C (5 to 158°F) (non-freezing)								
	Ambient Humidity	80% RH maximum (non-condensing), storage: 90% RH maximum (non-condensing)								
	Atmosphere	Indoors (no direct sunlight); no corrosive gas, inflammable gas, oil mist or dust								
	Vibration	49m/s ² maximum								
	Elevation	1000m or less above sea level								

Notes: 1. The linear servo motor's maximum speed or linear encoder's rated speed, whichever is smaller, is the upper limit value of the linear servo motor's speed.

LM-H2P1A-06M-4SS0(*1)

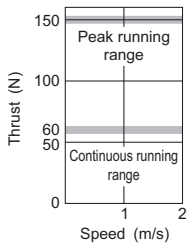

LM-H2P2A-12M-1SS0(*1)

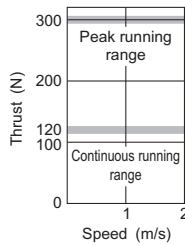

LM-H2P2B-24M-1SS0(*1)

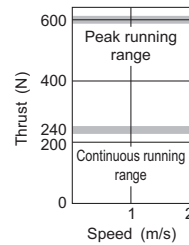

LM-H2P2C-36M-1SS0(*2)

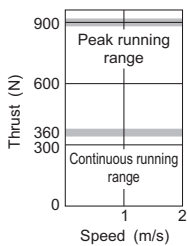

LM-H2P2D-48M-1SS0(*2)

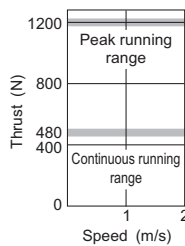

LM-H2P3A-24M-1SS0(*1)

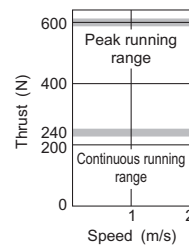

LM-H2P3B-48M-1SS0(*2)

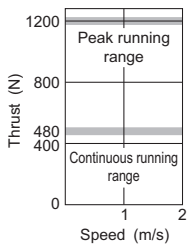

LM-H2P3C-72M-1SS0(*2)

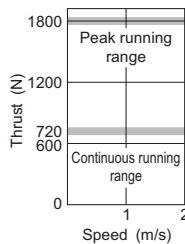

LM-H2P3D-96M-1SS0(*2)

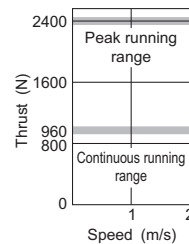

Notes:

- For 3-phase 200VAC or 1-phase 200VAC.
- For 3-phase 200VAC.

LM-F Series Linear Motor Specifications

Linear Servo Motor Model LM-F		P2B-06M-1SS0	P2D-12M-1SS0	P2F-18M-1SS0	P4B-12M-1SS0	P4D-24M-1SS0	P4F-36M-1SS0	P4H-48M-1SS0	P5H-60M-1SS0 (*2)
Compatible Amplifier MR-J3	Self-Cooling	200BRJ004U518	500BRJ004U520	700BRJ004U522	500BRJ004U524	700BRJ004U526	11KBRJ004U528	15KBRJ004U530	22KB4R-J004U532
	Liquid-Cooling	200BRJ004U519	500BRJ004U521	700BRJ004U523	500BRJ004U525	700BRJ004U527	11KBRJ004U529	15KBRJ004U531	22KB4R-J004U533
Power Facility Capacity (kVA)		3.5	5.5	10	7.5	18	18	18	22
Cooling Method		Self-cooling or liquid-cooling							
Thrust	Continuous (Self-Cooling) (N)	300	600	900	600	1200	1800	2400	3000
	Continuous (Liquid-Cooling) (N)	600	1200	1800	1200	2400	3600	4800	6000
	Maximum (N)	1800	3600	5400	3600	7200	10800	14400	18000
Maximum Speed (m/s) (*1)		2.0							
Magnetic Attraction Force (N)		4500	9000	13500	9000	18000	27000	36000	45000
Mass kg (lb)	Primary Side (coil)	9 (20)	18 (40)	27 (60)	14 (31)	28 (62)	42 (93)	56 (125)	67 (150)
	Secondary Side (Magnet)	480mm / piece: 7.1 (16) 576mm / piece: 9.0 (20)			480mm / piece: 13.5 (30) 576mm / piece: 16.0 (36)			480mm / piece: 20.0 (44) 576mm / piece: 26.0 (58)	
Secondary Side Model LM-F		S20_-1SS0			S40_-1SS0			S50_-1SS0	
Recommended Load / Motor Mass Ratio		Maximum of 15 times the mass of the linear servo motor's primary side							
Structure		Open (protection level: IP00)							
Environment	Ambient Temperature	0 to 40°C (32 to 104°F) (non-freezing), storage: -15 to 70°C (5 to 158°F) (non-freezing)							
	Ambient Humidity	80% RH maximum (non-condensing), storage: 90% RH maximum (non-condensing)							
	Atmosphere	Indoors (no direct sunlight); no corrosive gas, inflammable gas, oil mist or dust							
	Vibration	49m/s ² maximum							
	Elevation	1000m or less above sea level							

Notes:

- The linear servo motor's maximum speed or linear encoder's rated speed, whichever is smaller, is the upper limit value of the linear servo motor's speed.
- Use 400VAC rated servo amplifier.

LM-FP2B-06M-1SS0 (*1)

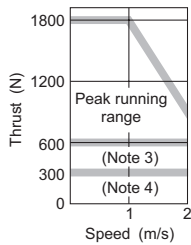

LM-FP2D-12M-1SS0 (*1)

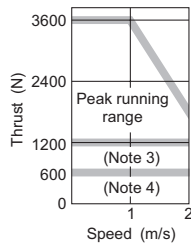

LM-FP2F-18M-1SS0 (*1)

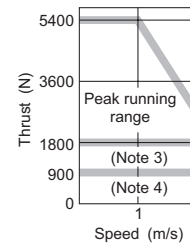

LM-FP4B-12M-1SS0 (*1)

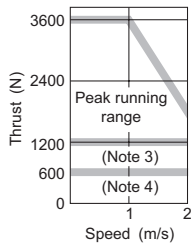

LM-FP4D-24M-1SS0 (*1)

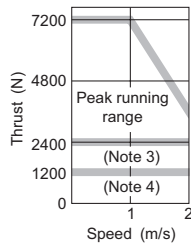

LM-FP4F-36M-1SS0 (*1)

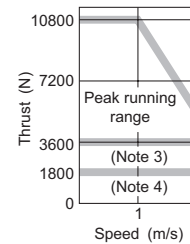

LM-FP4H-48M-1SS0 (*1)

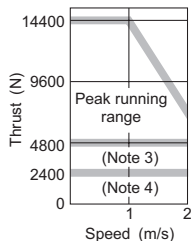

LM-FP5H-60M-1SS0 (*2)

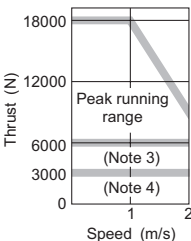

Notes:

- For 3-phase 200VAC.
- For 3-phase 400VAC.
- For continuous running range (liquid-cooling).
- For continuous running range (self-cooling).

LM-U2 Series Linear Motor Specifications

Linear Servo Motor Model LM-U2	PAB-05M-0SSO	PAD-10M-0SSO	PAF-15M-0SSO	PBB-07M-1SSO	PBD-15M-1SSO	PBF-22M-1SSO	P2B-40M-2SSO	P2C-60M-2SSO	P2D-80M-2SSO	
Compatible Amplifier MR-J3-	20B-RJ004U512	40B-RJ004U513	40B-RJ004U514	20B-RJ004U515	60B-RJ004U516	70B-RJ004U517	200B-RJ004U509	350B-RJ004U510	500B-RJ004U511	
Power Facility Capacity (kVA)	0.5	0.9	0.9	0.5	1.0	1.3	3.5	5.5	7.5	
Cooling Method	Self-cooling									
Thrust	Continuous (N)	50	100	150	75	150	225	400	600	800
	Maximum (N)	150	300	450	225	450	675	1600	2400	3200
Maximum Speed (m/s) (*1)	2.0									
Magnetic Attraction Force (N)	0									
Mass (kg) (lb)	Primary Side (Coil)	0.3 (0.67)	0.6 (1.4)	0.8 (1.8)	0.4 (0.89)	0.8 (1.8)	1.1 (2.5)	2.9 (6.4)	4.2 (9.3)	5.5 (13)
	Secondary Side (Magnet)	240mm / piece: 2.0 (4.4) 300mm / piece: 2.5 (5.6) 420mm / piece: 3.5 (7.8)			240mm / piece: 2.6 (5.8) 300mm / piece: 3.2 (7.1) 420mm / piece: 4.5 (10)			300mm / piece: 9.6 (22) 480mm / piece: 15.3 (34)		
Secondary Side Model LM-U2	SA0_-0SSO			SB0_-1SSO			S20_-2SSO			
Recommended Load / Motor Mass Ratio	Maximum of 30 times the mass of the linear servo motor's primary side									
Structure	Open (protection level: IP00)									
Environment	Ambient Temperature	0 to 40°C (32 to 104°F) (non-freezing), storage: -15 to 70°C (5 to 158°F) (non-freezing)								
	Ambient Humidity	80% RH maximum (non-condensing), storage: 90% RH maximum (non-condensing)								
	Atmosphere	Indoors (no direct sunlight); no corrosive gas, inflammable gas, oil mist or dust								
	Vibration	49m/s ² maximum								
	Elevation	1000m or less above sea level								

Notes:

- The linear servo motor's maximum speed or linear encoder's rated speed, whichever is smaller, is the upper limit value of the linear servo motor's speed.

LM-U2PAB-05M-0SSO (*1)

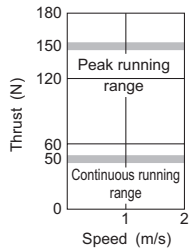

LM-U2PAD-10M-0SSO (*1)

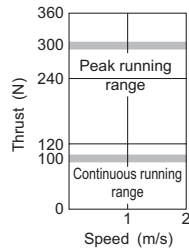

LM-U2PAF-15M-0SSO (*1)

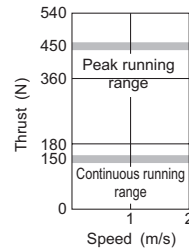

LM-U2PBB-07M-1SSO (*1)

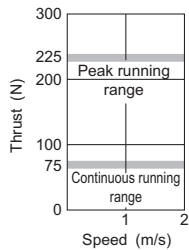

LM-U2PBD-15M-1SSO (*1)

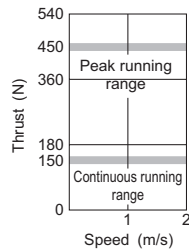

LM-U2PBF-22M-1SSO (*1)

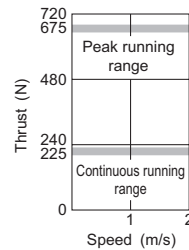

LM-U2P2B-40M-2SSO (*2)

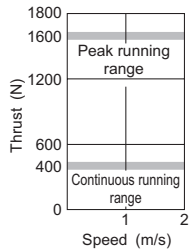

LM-U2P2C-60M-2SSO (*2)

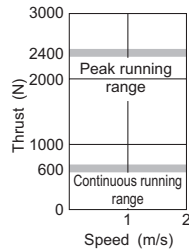

LM-U2P2D-80M-2SSO (*2)

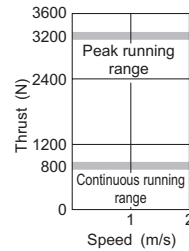

Notes:

- For 3-phase 200VAC or 1-phase 230VAC.
- For 3-phase 200VAC.

Linear Encoder

Compatible Linear Encoders (*1, *2)

Linear Encoder Type		Manufacturer	Model	Resolution	Rated Speed (*3)	Effective Measurement Length (Maximum)	Communication Method	Position System	
Mitsubishi Serial Interface Compatible	Absolute Type	Mitutoyo Corporation	AT343A	0.05mm	2.0m/s	3000mm	2-wire type	Absolute	
			AT543A-SC		2.5m/s	2200mm			
			ST741A	0.5mm	4.0m/s	6000mm			
			ST743A (*7)	0.1mm					
	Heidenhain Corporation	LC491M	0.05mm/ 0.01mm	2.0m/s	2040mm	4-wire type			
		LC192M		3.0m/s	4240mm				
	Incremental Type		Sony Manufacturing Systems Corporation	SL710+PL101-R/RH +MJ830 or MJ831	0.2mm (*4)	6.4m/s	3000mm	2-wire type	Incremental
				SH13 +MJ830 or MJ831	0.005mm (*4)	1.4m/s	1240mm		
			Renishaw Inc.	RGH26P	5mm	4.0m/s	7000mm		
				RGH26Q	1mm	3.2m/s			
RGH26R				0.5mm	1.6m/s				
Heidenhain Corporation			LIDA485+APE391M	0.005mm (20/4096mm)	4.0m/s	30040mm	4-wire type		
	LIDA487+APE391M	6040mm							
ABZ Phase Differential Output Type (*5)	Incremental Type	Not designated	-	Within tolerable resolution range (*6)	Depends on linear encoder	Depends on linear encoder	Differential 3-pair type		

Notes:

- Consult with the relevant linear encoder manufacturer for details on the linear encoder's working environment and specifications.
- The linear servo motor generates heat. Take the linear encoder's working environment temperature into consideration when configuring the system.
- The indicated values are the linear encoder's rated speed when used in combination with the Mitsubishi linear compatible servo amplifier. The values may differ from each manufacturer's specifications. The linear servo motor's maximum speed or linear encoder's rated speed, whichever is smaller, is the upper limit value of the linear servo motor's speed.
- The resolution varies according to the setting value of the interpolator, MJ830/MJ831 manufactured by Sony Manufacturing Systems Corporation. Set the resolution between the minimum resolution and 5mm.
- Output the A-phase, B-phase and Z-phase signals in the differential line driver. The phase difference of A-phase pulse and B-phase pulse, and the width of Z-phase pulse must be 200ns or wider. Home position return is not possible with a linear encoder which is not equipped with a Z-phase.
- The tolerable resolution range is 0.005 to 5mm. Select the linear encoder within this range.
- Servo amplifier with software version A1 or above is compatible with this linear scale.

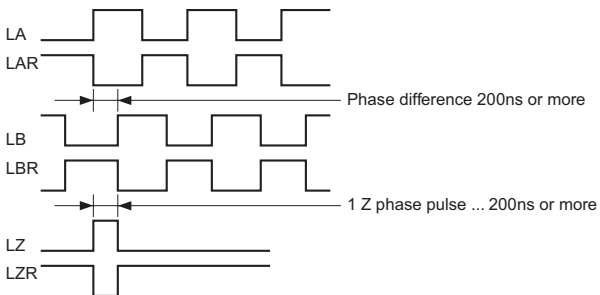

D MR-J3-Linear Cables and Connectors

Controller

Q173DCPU Q172HCPU MR-MQ100
 Q172DCPU Q173HCPU
 QD75MH Q170MCPUCPU

MR Configurator
 (Setup software)
 Software Version 5.00A or above (*1)

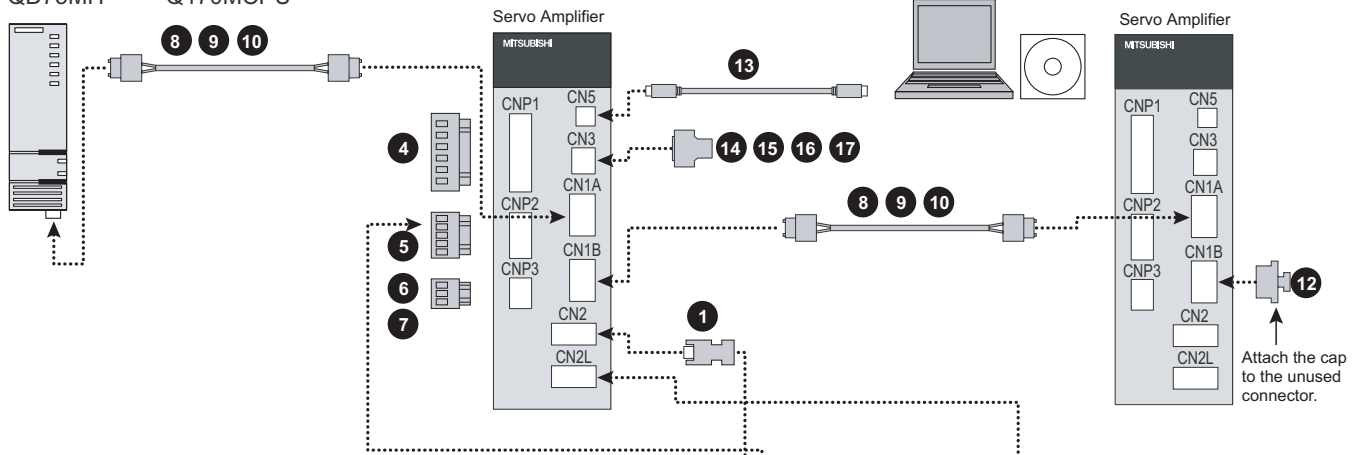

LM-H2 Series

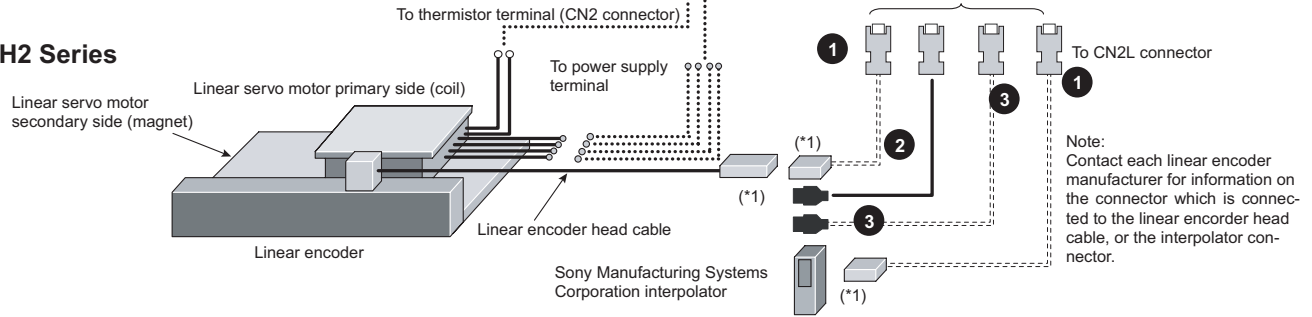

LM-F Series

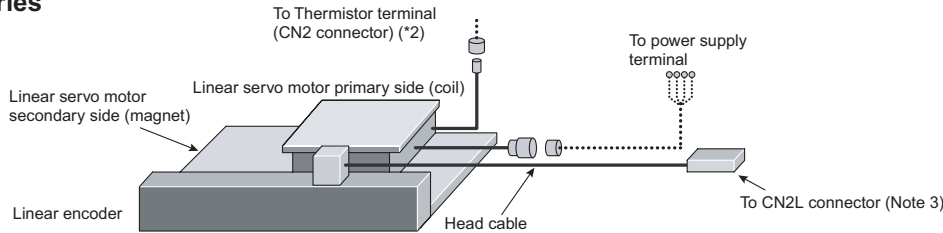

LM-U2 Series

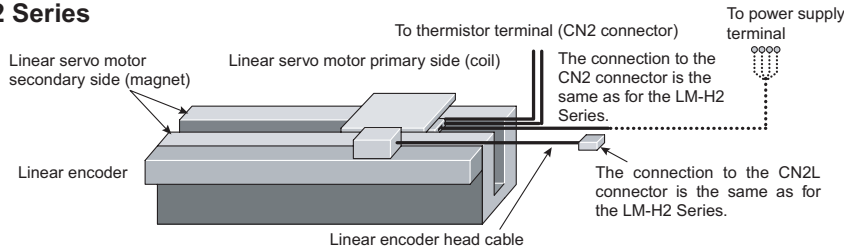













Notes:

- Setup software MR-Configurator Software version 5.00A or above is planned to be compatible with MR-J3-B-RJ004U_. Refer to the following for software versions of Q172HCPU and Q173HCPU compatible with linear servo LM Series.
 - Q172HCPU, Q173HCPU OS software (SW6RN-SV13MM /-SV22MM) Software version: 00D or above
 - Integrated start-up support software MT Developer (SW6RNC-GSVPROE/-GSVSETE) Software version: 00N or above
- The linear encoder, linear encoder head cable and encoder cable are not enclosed with the purchased linear servo motor and must be prepared by the user.
- Use the recommended linear encoder manufacturer's products for the linear encoder and linear encoder head cable.
- Consult with the linear encoder manufacturer regarding the working environment and specifications, and select the proper products.

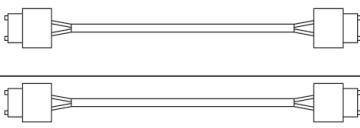
*Cautions regarding the linear encoders

- Linear encoder, head cable and encoder cable are not supplied with the linear servo motor.
- Linear encoder and head cable, manufactured by the recommended manufacturers, must be used.
- Consult relevant manufacturers for details on linear encoder's working environment and specifications.

MR-J3 Linear Servo Cables and Connectors

Item	Model	Stocked Lengths	Protection Level	Diagram	
①	CN2 or CN2L Connector	MR-J3CN2	S	IP20	
②	CN2 or CN2L Cable	MR-EKCBL_M-H (_ = cable length 2, 5, 20m)	2, 5, 10	IP20	
③	CN2 or CN2L Connector Set	MR-ECNM	S	IP20	
④	CNP1 Connector 1kW or less (comes with J3 Amp standard)	54928-0670	S	-	
	CNP1 Connector 2kW - 3.5kW (comes with J3 Amp standard)	PC4/6-STF-7.62	S	-	
⑤	CNP2 Connector up to 3.5kW (comes with J3 Amp standard)	54927-0510	S	-	
⑥	CNP3 Connector 1kW or less (comes with J3 Amp standard)	54928-0370	S	-	
	CNP3 Connector 2kW - 3.5kW (comes with J3 Amp standard)	PC4/3-STF-7.62	S	-	
⑦	CNP1-2-3 Insertion Tool (comes with J3 Amp standard)	54932-0000	S	-	
⑧	SSCNETIII Cable (standard cord for inside panel)	MR-J3BUS_M (_ = cable length 0.15, 0.3, 0.5, 1, 3m)	0.15, 0.3, 0.5, 1, 3	-	
⑨	SSCNETIII Cable (standard cable for outside panel)	MR-J3BUS_M-A (_ = cable length 5, 10, 20m)	5, 10, 20	-	
⑩	SSCNETIII Cable (long distance cable)	MR-J3BUS_M-B (_ = cable length 30, 40, 50m)	30	-	
⑫	Connector Cap for SSCNETIII	Connector comes with amplifier standard	-	-	
⑬	Personal Computer Communication Cable USB Cable	MR-J3USBCBL3M (cable length 3m)	S	-	
⑭	CN10 or CN3 Signal Connector (20 pin)	MR-J2CN1	S	-	
⑮	CN10 or CN3 Pigtail Cable (20 pin)	MR-CCN1CBL-_M (_ = cable length 3, 5m)	3, 5	-	
⑯	20 Pin Terminal B Lock for J3-B (TB20 cannot be used)	PS7DW-20V14B-F	S	-	
⑰	Cable for PS7DW-20V14B-F Terminal Block	MR-J2HBUS_M (_ = cable length 0.5, 1, 3, 5m)	0.5, 1, 3, 5	-	

E Software and Manuals

MR Configurator • (MRZJW3-SETUP221E)

This software makes it easy to perform setup, tuning, monitor display, diagnostics, reading and writing of parameters, and test operations with a personal computer. User-satisfying functions that enable the balance with the machine system, optimum control and short start up time are available.

- This software can set up and tune your servo system easily with a personal computer.
- Multiple monitor functions
Graphic display functions are provided to display the servo motor status with the input signal triggers, such as the command pulse, droop pulse and speed.
- Test operations with a personal computer
Test operation of the servo motors can be performed with a personal computer using multiple test mode menus.
- Further advanced tuning is possible with the improved advanced functions.

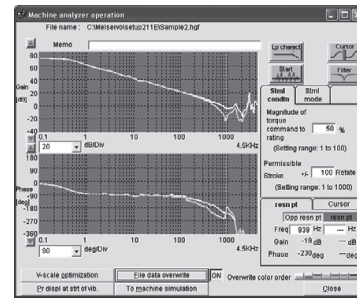

Description	Model Number	Stocked Item
Windows Communication Software	MR-CONFIGURATOR	S
Communication Cable	MR-J3USBCBL3M	S

Manuals

Hardware Description	Model Number	Stock Item
MR-J3-B-RJ004 Instruction Manual	SH(NA)030054	-

Note: Many of these manuals are available for free download from our website, www.meau.com

F Optional Accessories

RS-422 Distributor (For Multidrop)

Servo Amplifier Type	Model Number	Stock Item	Description
MR-J3-B-RJ004	BMJ-8	S	

20 Pin Terminal Block (*1)

Servo Amplifier Type	Model Number	Stock Item	Description
MR-J3-B-RJ004	PS7DW-20V14B-F	S	

Note: MR-TB20 terminal block cannot be used for MR-J3-B.

Battery

Item	Model Number	Description	Stock Item	Description
Battery	MR-J3BAT	The servo motor's absolute value can be maintained by installing the battery in the servo amplifier. The battery is not required when the servo system is used in an incremental mode.	S	
Battery Connection Relay Cable	MR-J3BTCBL03M	Use this relay cable to hold the absolute value when shipping the product with the machine and servo amplifier removed. The servo motor HF series does not have a super capacitor (for holding an absolute value for short time) in the encoder. When this optional cable is used, the absolute value can be held even when the encoder cable is disconnected from the servo amplifier, making it easy to do maintenance on the servo amplifier.	S	

Line Noise Filter

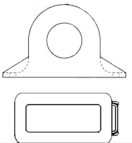
Servo Amplifier Type	Model Number	Stock Item	Description
MR-J3-200B-RJ004 or smaller	FR-BSF01	S	
MR-J3-350B-RJ400 or larger	FR-BLF	S	

EMC Filter

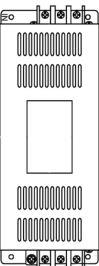
Servo Amplifier Type	Model Number	Stock Item	Description
MR-J3-70B-RJ004 and less	HF3010A-UN	S	
MR-J3-200B-RJ004 ~ 350B-RJ004	HF3030A-UN	S	
MR-J3-500B-RJ004 ~ 700R-J004	HF3040A-UN	S	
MR-J3-11KB-RJ004 ~ 15K-RJ004	HF3100A-UN	S	

Brake/Resistor Units (Must be used in conjunction with each other)

Servo Amplifier Model	Brake Unit Model Number	Stock Item	Resistor Unit Model Number	Stock Item
MR-J3-500B-RJ004 ~ 700B-RJ004	FR-BU2-15K	S	FR-BR-15K-UL	S
MR-J3-11KB-RJ004 ~ 15K-RJ004	FR-BU2-30K	S	FR-BR-30K-UL	S

DC Power Improvement Reactor

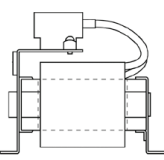
Servo Amplifier Type	Model Number	Stock Item	Diagram
MR-J3-40B-RJ004	DCA000902	-	
MR-J3-70B-RJ004		-	
MR-J3-200B-RJ004	DCA001802	-	
MR-J3-350B-RJ004	DCA003202	-	
MR-J3-500B-RJ004	DCA005001	-	
MR-J3-700B-RJ004 ~ 11K-RJ004	DCA008002	-	
MR-J3-15K-RJ004	DCA011003	-	
MR-J3-22K4-RJ004	DCA008005	-	

Optional Regeneration Resistors

Servo Amplifier Model (MR-J3-)	Capacitor Charging (J)	Inverse Efficiency (%)	Built-in Regenerative Resistor/Tolerable Regenerative Power (W)	External Regenerative Resistor/Standard Accessory	Optional Regeneration Resistors/Tolerable Regenerative Power (W)									
					MR-RB									
					032 (40W)	12 (40W)	30 (13W)	31 (6.7W)	32 (40W)	50 (13W) (*1)	51 (6.7W) (*1)	5E (6W) (*2)	9P (4.5W) (*2)	6K-4 (10W) (*2)
Stocked Item	N/A	N/A	-	N/A	S	S	S	-	S	S	S	-	-	-
20B-RJ004U	9	70	10	-	30	100	-	-	-	-	-	-	-	-
40B-RJ004U	11	85	10	-	30	100	-	-	-	-	-	-	-	-
60B-RJ004U	11	85	10	-	30	100	-	-	-	-	-	-	-	-
70B-RJ004U	18	80	20	-	30	100	-	-	300	-	-	-	-	-
200B-RJ004U	40	85	100	-	-	-	300	-	-	500	-	-	-	-
350B-RJ004U	40	85	100	-	-	-	300	-	-	500	-	-	-	-
500B-RJ004U	45	90	130	-	-	-	-	300	-	-	500	-	-	-
700B-RJ004U	70	90	170	-	-	-	-	300	-	-	500	-	-	-
11KB-RJ004U	120	90	-	500 (800)	-	-	-	-	-	-	-	500 (800)	-	-
15KB-RJ004U	170	90	-	850 (1300)	-	-	-	-	-	-	-	-	850 (1300)	-
22KB4-RJ004U	250	90	-	850 (1300)	-	-	-	-	-	-	-	-	-	850 (1300)

Notes:

- Be sure to install cooling fans. The cooling fan must be prepared by the user.
- The values in () indicate when cooling fans (2 units of 92 x 92 mm, minimum air flow: 1.03/min) are installed, and the parameter No. PA02 is changed.

Radio Noise Filter

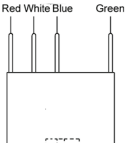
Servo Amplifier Type	Model Number	Stock Item	Description
All 200VAC J3 Models	FR-BIF	S	
All 400VAC J3 Models	FR-BIF-H	-	

Power Regeneration Converter

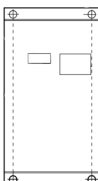
Servo Amplifier Type	Model Number	Stock Item	Description
MR-J3-500B-RJ004	FR-RC-15K	-	
MR-J3-700B-RJ004 ~ 15K-RJ004	FR-RC-30K	-	

Power Regeneration Common Converter/Stand-Alone Reactor

(Must be used in conjunction with each other). Up to six servo amplifiers can be connected to one FR-CV, refer to manuals for details.

Servo Amplifier Model	Common Converter Model Number	Stock Item	Reactor Model Number	Stock Item
MR-J3-350B-RJ004	FR-CV-7.5K	-	FR-CVL-7.5K	-
MR-J3-500B-RJ004	FR-CV-11K	-	FR-CVL-15K	-
MR-J3-700B-RJ004	FR-CV-15K	-	FR-CVL-11K	-
MR-J3-11KB-RJ004	FR-CV-22K	-	FR-CVL-22K	-
MR-J3-15KB-RJ004	FR-CV-30K	-	FR-CVL-30K	-
	FR-CV-37K	-	FR-CVL-37K	-

AC Power Factor Improvement Reactor

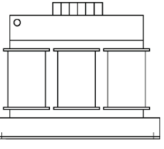
Servo Amplifier Type	Model Number	Stock Item	Description
MR-J3-40B-RJ004	MRL-00401	-	
MR-J3-70B-RJ004	MRL-00801	-	
MR-J3-200B-RJ004	MRL-01801	S	
MR-J3-350B-RJ004	MRL-03501	-	
MR-J3-500B-RJ004	MRL-04501	-	
MR-J3-700B-RJ004 ~ 11K-RJ004	MRL-05501	-	
MR-J3-15K-RJ004	MRL-08001	-	
MR-J3-22K4-RJ004	MRL-05502	-	

MR-J3 Direct Drive Servo Motors and Amplifiers

Direct drive motor is newly added to the MELSERVO-J3 Series. Direct drive arrangement with the motor provides higher rigidity. In addition, the high-resolution encoder with the motor enables high accuracy control. The motor's low profile design contributes to compact construction and a low center of gravity for enhanced machine stability. This motor is suitable for rotation and index tables used in semiconductor manufacturing, liquid crystal manufacturing and machine tool devices. The direct drive motor and servo amplifier will be compatible with global standards (EN, UL and cUL standards).

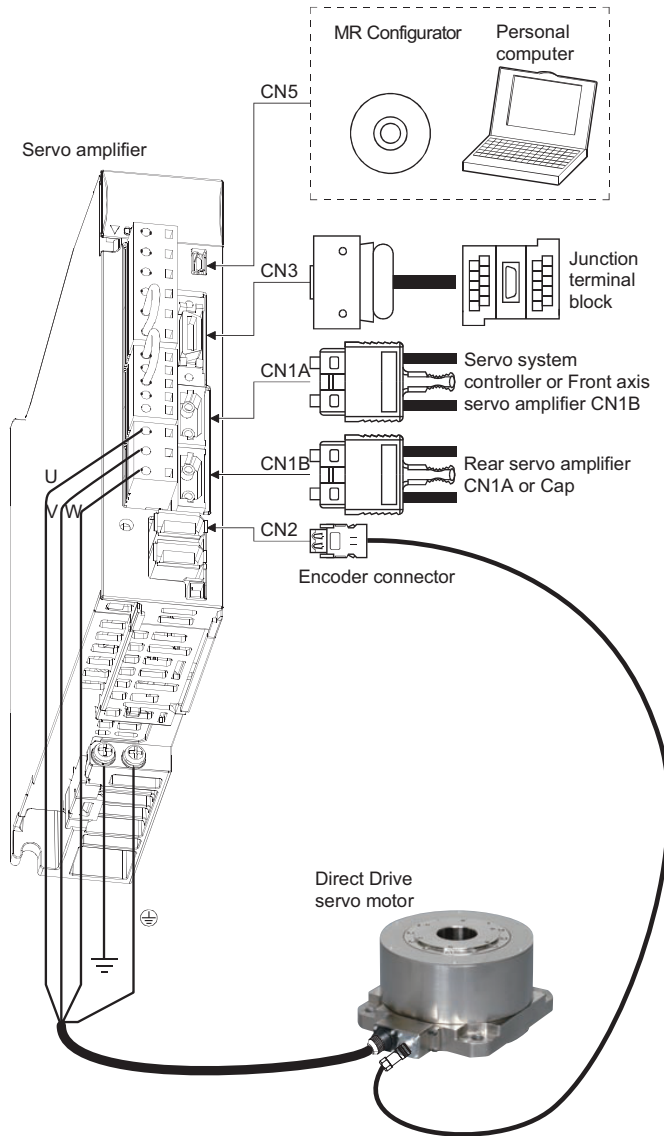

A. Amplifier.....	327
B. Motor	327
C. Cables and Connectors.....	330
D. Software and Manuals.....	332
E. Optional Accessories.....	332

A MR-J3-Direct Drive Amplifiers

Amplifier Selection

MR-J3 - □ - B - □

MELSERVO-J3 Series

SSCNET II Compatible

Symbol	Description
RJ080W	Direct drive motor compatible, with a built-in dynamic brake
RU080W	Direct drive motor compatible, without a dynamic brake (*1)

Note 1: Dynamic brake does not work at alarm occurrence or power failure. Take measures to ensure safety.

Symbol	Compatible Motors
	TM-RFM
20	002C20
40	004C20
60	006C20, 006E20
70	012E20, 012G20, 040J10
100	018E20
350	048G20, 072G20, 120J10
500	240J10

Conforms to the following standards: EN, UL, cUL

B MR-J3-Direct Drive Servomotors

Motor Selection

TM-RFM - □ □ □

Direct Drive Motor Series

Conforms to the following standards: EN, UL, cUL

Symbol	Rated Torque (N·m)
002	2
004	4
006	6
012	12
018	18
040	40
048	48
072	72
120	120
240	240

Symbol	Rated Speed (r/min)
10	100
20	200

Symbol	Motor Outer Diameter (mm) Frame Dimensions)
C	130
E	180
G	230
J	330

Amplifier Specifications

MR-J3-_-RJ080W		20B	40B	60B	70B	100B	350B	500B
Main Circuit Power Supply	Voltage / Frequency (*1, *2)	3-phase 200 to 230VAC 50/60Hz or 1-phase 200 to 230VAC 50/60Hz				3-phase 200 to 230VAC 50/60Hz		
	Permissible Voltage Fluctuation	For 3-phase 200 to 230VAC: 3-phase 170 to 253VAC For 1-phase 200 to 230VAC: 1-phase 170 to 253VAC				3-phase 170 to 253VAC		
	Permissible Frequency Fluctuation	±5% maximum						
Control Circuit Power Supply	Voltage / Frequency	1-phase 200 to 230VAC 50/60Hz						
	Permissible Voltage Fluctuation	1-phase 170 to 253VAC						
	Permissible Frequency Fluctuation	±5% maximum						
	Power Consumption (W)	30						45
Interface Power Supply		24VDC±10% (required current capacity: 0.15A (*3))						
Control System		Sine-wave PWM control/current control system						
Dynamic Brake		Built-in (*4, *5)						
Safety Features		Overcurrent shutdown, regeneration overvoltage shutdown, overload shutdown (electronic thermal), direct drive motor overheat protection, encoder fault protection, regeneration fault protection, undervoltage/sudden power outage protection, overspeed protection, excess error protection, magnetic pole detection protection, servo control error protection						
Structure		Natural-cooling, open (IP00)				Fan-cooling, open (IP00)		
Environment	Ambient Temperature (*6)	0 to 55°C (32 to 131°F) (non freezing), storage: -20 to 65°C (-4 to 149°F) (non freezing)						
	Ambient Humidity	90% RH maximum (non condensing), storage: 90% RH maximum (non condensing)						
	Atmosphere	Indoors (no direct sunlight); no corrosive gas, inflammable gas, oil mist or dust						
	Elevation	1000m or less above sea level						
Vibration		5.9m/s ² or less at 10 to 55Hz (directions of X, Y and Z axes)						
Mass		0.8 (1.8)	1.0 (2.2)	1.0 (2.2)	1.4 (3.1)	1.4 (3.1)	2.3 (5.1)	4.6 (10)

Notes:

- Rated output and speed of a direct drive motor are applicable when the servo amplifier, combined with the direct drive motor, is operated within the specified power supply voltage and frequency. Torque drops when the power supply voltage is below the specified value.
- For torque characteristics when combined with a direct drive motor, refer to the section "Direct drive motor torque characteristics" in this catalog.
- 0.15A is the value when all of the input/output points are used. The current capacity can be stepped down according to the number of input/output points in use. Refer to "MR-J3_B SAFETY SERVO AMPLIFIER INSTRUCTION MANUAL" for details.
- When using the built-in dynamic brake, refer to "MR-J3_B-RJ080W INSTRUCTION MANUAL" for the permissible load inertia moment ratio.
- Special specification servo amplifiers without a dynamic brake are also available: MR-J3-_B-RU080W. When using the servo amplifier without a dynamic brake, the direct drive motor does not stop immediately at alarm occurrence or power failure. Take measures to ensure safety in the entire system.
- The following servo amplifiers can be mounted closely: MR-J3-20B-RJ080W, -40B-RJ080W, -60B-RJ080W, -70B-RJ080W, -100B-RJ080W and -350B-RJ080W. In this case, operate them at the ambient temperature of 0 to 45°C (32 to 113°F) or at 75% or less of the effective load ratio.

Direct Drive Servomotor Specifications

Direct Drive Motor Model TM-RFM		002C20	004C20	006C20	006E20	012E20	018E20
Compatible Servo Amplifiers		20B	40B	60B	60B	70B	100B
Motor Outer Diameter (Frame Dimensions) (mm)		ø130			ø180		
Power Supply Capacity (kVA) (*1)		0.25	0.38	0.53	0.46	0.81	1.3
Continuous Running Duty	Rated Output (W)	42	84	126	126	251	377
	Rated Torque (N·m [oz·in])	2 (283)	4 (566)	6 (850)	6 (850)	12 (1700)	18 (2550)
Maximum Torque (N·m [oz·in])		6 (850)	12 (1700)	18 (2550)	18 (2550)	36 (5100)	54 (7650)
Rated Speed (r/min)		200					
Maximum Speed (r/min)		500					
Permissible Instantaneous Speed (r/min)		575					
Power Rate at Continuous Rated Torque (kW/s)		3.7	9.6	16.1	4.9	12.9	21.8
Rated Current (A)		1.3	2.1	3.1	3.1	3.8	5.9
Maximum Current (A)		3.9	6.3	9.3	9.3	12	18
Regenerative Braking Frequency (*2) (times/min)		No limit	4600	2600	510	560	400
Moment of Inertia J (x10 ⁻⁴ kg·m ²) [J (oz·in ²)]		10.9 (59.6)	16.6 (90.8)	22.4 (122)	74.0 (405)	111 (607)	149 (815)
Recommended Load to Motor Inertia Moment Ratio (*3)		Maximum of 50 times					
Absolute Accuracy (s)		±15			±12.5		
Encoder Resolution		1048576p/rev (Absolute/incremental encoder) (*4)					
Insulation Class		Class F					
Structure		Totally enclosed non ventilated (IP rating: IP42) (*5)					
Rotor Permissible Load (*8)	Moment Load (N·m [oz·in])	22.5 (3190)			70 (9910)		
	Axial Load (N)	1100			3300		
Environment (*7)	Ambient Temperature	0 to 40°C (32 to 104°F) (non freezing), storage: -15 to 70°C (5 to 158°F) (non freezing)					
	Ambient Humidity	80% RH maximum (non condensing), storage: 90% RH maximum (non condensing)					
	Atmosphere	Indoors (no direct sunlight); no corrosive gas, inflammable gas, oil mist, dust or splash of oil or water					
	Elevation	1000m or less above sea level					
	Vibration (*6)	X: 49m/s ² Y: 49m/s ²					
Mass (kg [lb])		5.2 (12)	6.8 (15)	8.4 (19)	11 (25)	15 (33)	18 (40)

Notes:

- The power supply capacity varies depending on the power supply's impedance.
- The regenerative braking frequency shows the permissible frequency when the motor, without a load and optional regeneration unit, decelerates from the rated speed to a stop. When a load is connected; however, the value will be the table value/(m+1), where m=the load inertia moment/the motor inertia moment. When the operating speed exceeds the rated speed, the regenerative braking frequency is inversely proportional to the square of (operating speed/rated speed). If the operating speed changes frequently or when the regeneration is constant (as with vertical feeds), find the regenerative heating value (W) in operation. Provisions must be made to keep this heating value below the tolerable regenerative power (W). Optimal regenerative resistor varies for each system. Select the most suitable regenerative resistor by using the Servo Support software. Refer to the section "Options Optional regeneration unit" in this catalog for details on the tolerable regenerative power (W).
- Contact your local sales office if the load to motor inertia moment ratio exceeds the value in the table.
- Optional absolute position storage unit (MR-BTAS01) and battery (MR-J3BAT) are required for absolute position detecting system. Refer to "MR-J3_B-RJ080W INSTRUCTION MANUAL" for details.
- Connectors and gap between rotor and stator are excluded.
- The vibration direction is shown in the diagram to the right. The numeric value indicates the maximum value of the component (commonly the bracket in the opposite direction of the motor shaft). Fretting of the bearing occurs easily when the motor stops, so maintain vibration to approximately one-half of the allowable value.



- In the environment where the direct drive motor is exposed to oil mist, oil and/or water, a standard specification direct drive motor may not be usable. Contact your local sales office for more details.
- The following is calculation examples of axial and moment loads to the rotor (output shaft). The axial and moment loads must be maintained equal to or below the permissible value.

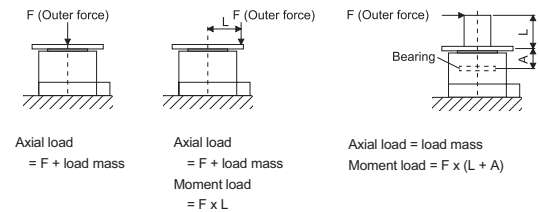

Motor outer diameter (mm) (Frame dimensions)	Dimension A (mm)
ø130	19.1
ø180	20.2

Direct Drive Motor Machine Accuracy

The machine accuracy related to the direct drive motor's rotor (output shaft and instillation is indicated below.)

Item	Measured Part	Accuracy (mm)
Runout of flange surface about rotor (output shaft)	a	0.05
Runout of fitting outer diameter of flange surface	b	0.07
Runout of rotor (output shaft)	c	0.04
Runout of rotor (output shaft) end	d	0.02

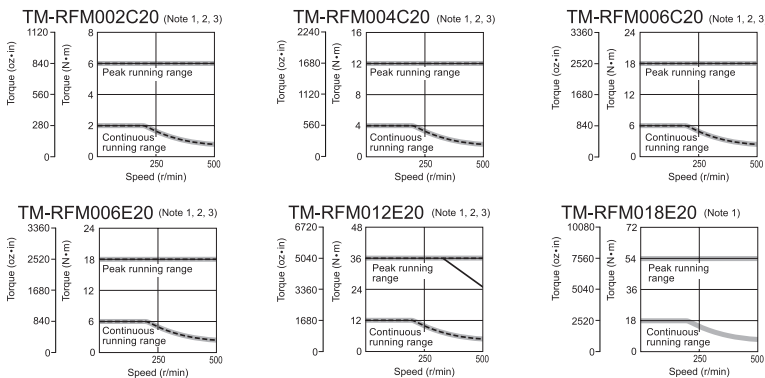

Notes:
 1. ———: For 3-phase 200VAC.
 2. - - - - : For 1-phase 230VAC.
 3. ———: For 1-phase 200VAC.
 This line is drawn only where differs from the other two lines.

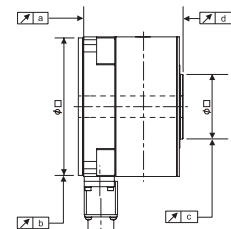

Servomotor Specifications

Direct Drive Motor Model TM-RFM		012G20	048G20	072G20	040J10	120J10	240J10
Compatible Servo Amplifiers		70B	350B		70B	350B	500B
Motor Outer Diameter (Frame Dimensions) (mm)		Ø230			Ø330		
Power Supply Capacity (kVA) (*1)		0.71	2.7	3.8	1.2	3.4	6.6
Continuous Running Duty	Rated Output (W)	251	1005	1508	419	1257	2513
	Rated Torque (N·m [oz·in])	12 (1700)	48 (6800)	72 (10200)	40 (5660)	120 (17000)	240 (34000)
Maximum Torque (N·m [oz·in])		36 (5100)	144 (20400)	216 (30600)	120 (17000)	360 (51000)	720 (102000)
Rated Speed (r/min)		200			100		
Maximum Speed (r/min)		500			200		
Permissible Instantaneous Speed (r/min)		575			230		
Power Rate at Continuous Rated Torque (kW/s)		6.0	37.5	59.3	9.4	40.9	91.4
Rated Current (A)		3.4	10.9	16	4.3	11	20
Maximum Current (A)		10	33	48	13	33	60
Regenerative Braking Frequency (*2) (times/min)		200	350	250	120	70	40
Moment of Inertia J (x10 ⁻⁴ kg·m ²) [J (oz·in ²)]		238 (1300)	615 (3360)	875 (4780)	1694 (9260)	3519 (19200)	6303 (34500)
Recommended Load to Motor Inertia Moment Ratio (*3)		Maximum of 50 times					
Absolute Accuracy (s)		±12.5			±10		
Encoder Resolution		1048576p/rev (Absolute/incremental encoder) (*4)					
Insulation Class		Class F					
Structure		Totally enclosed non ventilated (IP rating: IP42) (*5)					
Rotor Permissible Load (*8)	Moment Load (N·m [oz·in])	93 (13200)			350 (49600)		
	Axial Load (N)	5500			16000		
Environment (*7)	Ambient Temperature	0 to 40°C (32 to 104°F) (non freezing), storage: -15 to 70°C (5 to 158°F) (non freezing)					
	Ambient Humidity	80% RH maximum (non condensing), storage: 90% RH maximum (non condensing)					
	Atmosphere	Indoors (no direct sunlight); no corrosive gas, inflammable gas, oil mist, dust or splash of oil or water					
	Elevation	1000m or less above sea level					
Vibration (*6)		X: 49m/s ² Y: 49m/s ²			X: 24.5m/s ² Y: 24.5m/s ²		
Mass (kg [lb])		17 (38)	36 (80)	52 (115)	53 (120)	91 (205)	146 (325)

Notes:

- The power supply capacity varies depending on the power supply's impedance.
- The regenerative braking frequency shows the permissible frequency when the motor, without a load and optional regeneration unit, decelerates from the rated speed to a stop. When a load is connected; however, the value will be the table value/(m+1), where m=the load inertia moment/the motor inertia moment. When the operating speed exceeds the rated speed, the regenerative braking frequency is inversely proportional to the square of (operating speed/rated speed). If the operating speed changes frequently or when the regeneration is constant (as with vertical feeds), find the regenerative heating value (W) in operation. Provisions must be made to keep this heating value below the tolerable regenerative power (W). Optimal regenerative resistor varies for each system. Select the most suitable regenerative resistor by using the Servo Support software. Refer to the section "Options Optional regeneration unit" in this catalog for details on the tolerable regenerative power (W).
- Contact your local sales office if the load to motor inertia moment ratio exceeds the value in the table.
- Optional absolute position storage unit (MR-BTAS01) and battery (MR-J3BAT) are required for absolute position detecting system. Refer to "MR-J3-B-RJ080W INSTRUCTION MANUAL" for details.
- Connectors and gap between rotor and stator are excluded.
- The vibration direction is shown in the diagram to the right. The numeric value indicates the maximum value of the component (commonly the bracket in the opposite direction of the motor shaft). Fretting of the bearing occurs easily when the motor stops, so maintain vibration to approximately one-half of the allowable value.



- In the environment where the direct drive motor is exposed to oil mist, oil and/or water, a standard specification direct drive motor may not be usable. Contact your local sales office for more details.
- The following is calculation examples of axial and moment loads to the rotor (output shaft). The axial and moment loads must be maintained equal to or below the permissible value.

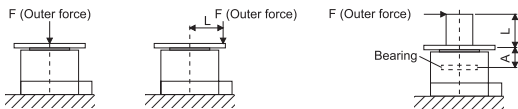

Axial load
= F + load mass

Axial load
= F + load mass

Axial load = load mass
Moment load = F x (L + A)

Moment load
= F x L

Motor outer diameter (mm) (Frame dimensions)	Dimension A (mm)
Ø230	24.4
Ø330	32.5

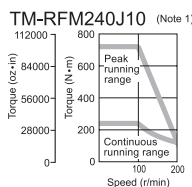
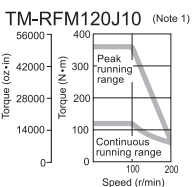
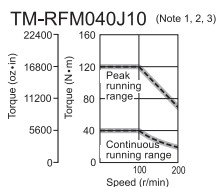
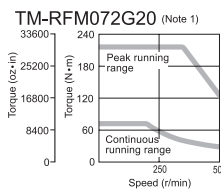
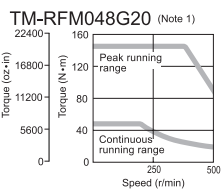
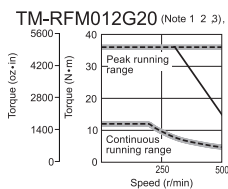

- Notes:
- : For 3-phase 200VAC.
 - - -: For 1-phase 230VAC.
 - : For 1-phase 200VAC.
- This line is drawn only where it differs from the other two lines.

Direct Drive Motor Machine Accuracy

The machine accuracy related to the direct drive motor's rotor (output shaft and installation is indicated below.)

Item	Measured Part	Accuracy (mm)
Runout of flange surface about rotor (output shaft)	a	0.05
Runout of fitting outer diameter of flange surface	b	0.07
Runout of rotor (output shaft)	c	0.04
Runout of rotor (output shaft) end	d	0.02

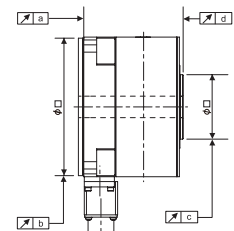

G Cables

- Q173DCPU
- Q172DCPU
- Q170MCPUCPU
- QD75MH
- QD74MH
- MR-MQ100

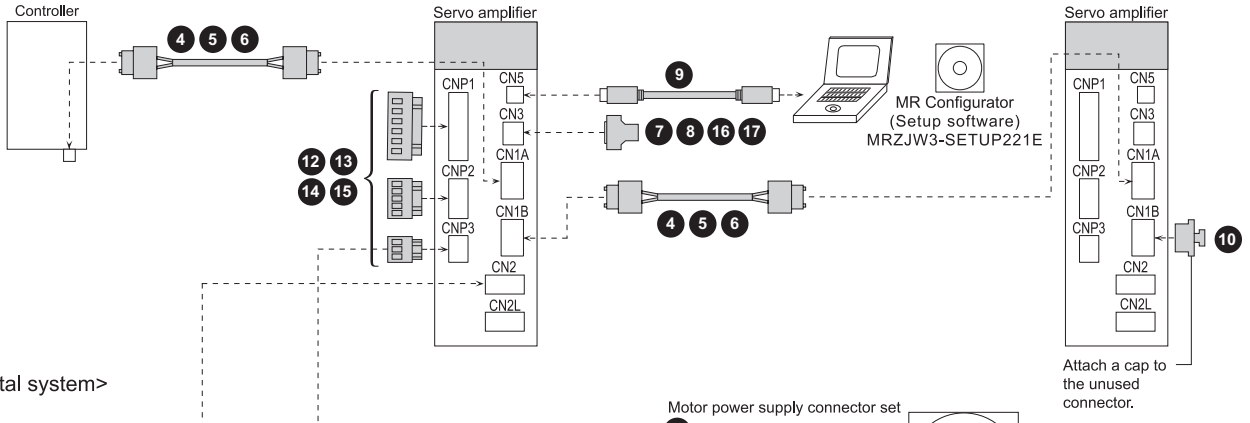

<For incremental system>

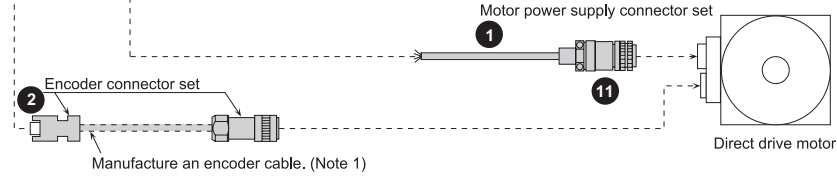



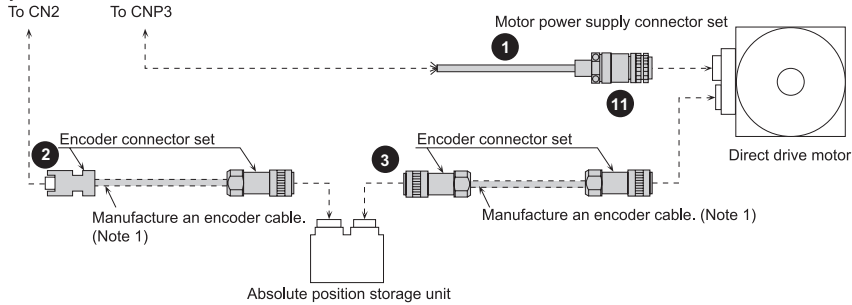









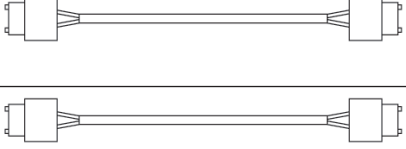



<For absolute position detecting system>



Cables

Item	Motor Model Number	Cable Number (= cable length 2, 5, 10, 15, 20, 25, 30 meter)	Stocked Lengths (m)	Protection Level	Description			
Power Cables for TM-RFM Series Direct Drive Motors	Standard-Flex, Unshielded Type Cables (straight Type Connector Only)	TM-RFM002C20	MR7S-_M	IP65				
		TM-RFM004C20						
		TM-RFM006C20						
		TM-RFM006E20	MR7S-_M					
		TM-RFM012E20						
		TM-RFM018E20						
		TM-RFM012G20	MR-J3P1-_M			2, 5, 10, 20, 30		
		TM-RFM048G20	MR-J3P3-_M					
		TM-RFM072G20	MR-J3P4-_M					
		TM-RFM040J10				2, 5, 10, 20, 30		
	TM-RFM120J10							
	TM-RFM240J10	MR-J3P7-_M						
	High-Flex, Shielded Type Cables (straight Type Connector Only)	TM-RFM002C20	MR7S-SH-_M	-		IP65		
		TM-RFM004C20						
		TM-RFM006C20						
		TM-RFM006E20	MR7S-SH-_M					
		TM-RFM012E20						
		TM-RFM018E20						
		TM-RFM012G20	MR-J3PWS1-_M				-	IP67
		TM-RFM048G20	MR-J3PWS3-_M					
TM-RFM072G20		MR-J3PWS4-_M						
TM-RFM040J10			-					
TM-RFM120J10								
TM-RFM240J10	MR-J3PWS7-_M							

Cables continued

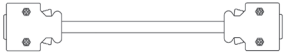
			Model	Stocked Lengths (m)	IP Rating (*5)	Description
For Encoder	2	Encoder Connector Set (for connecting servo amplifier and direct drive motor, or for connecting servo amplifier and absolute position storage unit)	MR-J3DDCNS	S	IP67	
	3	Encoder Connector Set (for connecting absolute position storage unit and direct drive motor)	MR-J3DDSPS	S	IP67	
For Controller: CN1A, CN1B	4	SSCNET III Cable (*1) (Standard Cord for Inside Panel)	MR-J3BUS_M _ = cable length: 0.15, 0.3, 0.5, 1, 3m	0.15, 0.3, 0.5, 1, 3	-	
	5	SSCNET III Cable (*1) (Standard Cable for Outside Panel)	MR-J3BUS_M-A _ = cable length: 5, 10, 20m	5, 10, 20	-	
	6	SSCNET III Cable (*1) (Long Distance Cable, Long Bending Life)	MR-J3BUS_M-B _ = cable length: 30, 40, 50m (*2)	30	-	
For CN3	7	CN20 or CN3 Pigtail Cable (20 Pin)	MR-CCN1CBL-_M _ = cable length 3, 5m)	3, 5	-	
For CN3	8	Input/Output Signal Connector Set	MR-J2CN1	S	-	
For CN5	9	Personal Computer Communication Cable - USB	MR-J3USBCBL3M Cable length: 3m	S	-	
For CN1B	10	Connector Cap for SSCNET III	(Standard accessory)	-	-	
For Motor Power Supply	11	Power Supply Connector Set for TM-RFM_C20, TM-RFM_E20	MR-PWCNF (straight type)	S	IP67	
		Power Supply Connector set for TM-RFM_G20	MR-PWCNS4 (straight type)	S	IP67	
		Power Supply Connector Set for TM-RFM040J10, TM-RFM120J10	MR-PWCNS5 (straight type)	S	IP67	
		Power Supply Connector Set for TM-RFM240J10	MR-PWCNS3 (straight type)	S	IP67	
Power Connectors (Comes with J3 Amplifier standard)	12	CNP1 Connector 1kW or Less (200VAC)	54928-0670	S	-	
		CNP1 Connector 2kW - 3.5kW (200VAC) (*6)	PC4/6-STF-7.62	S	-	
	13	CNP2 Connector up to 3.5kW (200VAC) (*6)	54927-0510	S	-	
	14	CNP3 Connector 1kW or Less (200VAC)	54928-0370	S	-	
		CNP3 Connector 2kW - 3.5kW (200VAC) (*6)	PC4/3-STF-7.62	S	-	
15	CNP1-2-3 Insertion Tool (200VAC)	54932-0000	S	-		
For CN3	16	20 Pin Terminal Block For J3-B (TB20 Cannot be Used)	PS7DW-20V14B-F	S	-	
	17	Cable for PS7DW-20V14B-F Terminal Block	MR-J2HBUS_M _ = Cable length 05, 1, 3, 5m)	0.5, 1, 3, 5	-	

Notes:

1. Look carefully through the precautions enclosed with the options before use.
2. Contact your local sales office for the cables with ultra-long bending life and/or for unlisted lengths.
3. Special tools are required. Contact your local sales office for details.
4. The connector and shell kit are soldered type. Models for press bonding type are 10120-6000EL (connector) and 10320-3210-000 (shell kit).
5. The IP rating indicated is for the connector's protection against ingress of dust and water when coupled to a servo amplifier/direct drive motor. If the IP rating of the servo amplifier/direct drive motor differs from that of these connectors, overall IP rating depends on the lowest of all.
6. Use this model for amplifiers manufactured prior to January 2008.

D Software and Manuals

MR Configurator • (MRZJW3-SETUP221E)

This software makes it easy to perform setup, tuning, monitor display, diagnostics, reading and writing of parameters, and test operations with a personal computer. User-satisfying functions that enable the balance with the machine system, optimum control and short start up time are available.

- This software can set up and tune your servo system easily with a personal computer.
- Multiple monitor functions. Graphic display functions are provided to display the servo motor status with the input signal triggers, such as the command pulse, droop pulse and speed.
- Test operations with a personal computer. Test operation of the servo motors can be performed with a personal computer using multiple test mode menus.
- Further advanced tuning is possible with the improved advanced functions.

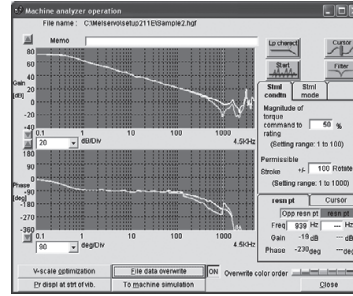

Manuals

Hardware Description	Model Number	Stocked Item
MR-J3-B-RJ080W	-	-

Note: Many of these manuals are available for free download from our website, www.meau.com

Description	Model Number	Stocked Item
Windows Communication Software	MR-CONFIGURATOR	S
Communication Cable	MR-J3USBCBL3M	S

E System Options

RS-422 Distributor (For Multidrop)

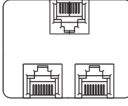
Servo Amplifier Type	Model Number	Stocked Item	Description
MR-J3-B	BMJ-8	S	

20 Pin Terminal Block (*1)

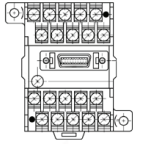
Servo Amplifier Type	Model Number	Stocked Item	Description
MR-J3-B	PS7DW-20V14B-F	S	

Note: MR-TB20 terminal block cannot be used for MR-J3-B.

Line Noise Filter

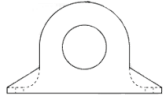
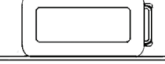
Servo Amplifier Type	Model Number	Stocked Item	Description
MR-J3-200B or Smaller	FR-BSF01	S	
MR-J3-350B or Larger	FR-BLF	S	

Radio Noise Filter

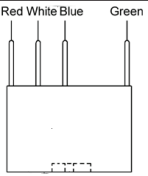
Servo Amplifier Type	Model Number	Stocked Item	Description
All 200VAC J3 Models	FR-BIF	S	

EMC Filter

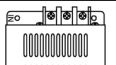
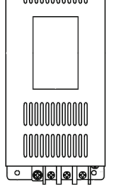
Servo Amplifier Type	Model Number	Stocked Item	Description
MR-J3-100B and less	HF3010A-UN	S	
MR-J3-200B ~ 350B	HF3030A-UN	S	

Battery

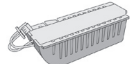
Model Number	Description	Stock Item	Description
MR-J3BAT	The servo motor's absolute value can be maintained by installing the battery in the servo amplifier. The battery is not required when the servo system is used in an incremental mode.	S	

Absolute Position Storage Unit

Model Number	Description	
MR-BTAS01	Ambient Temperature	0 to 55°C (32 to 131°F) Non-freezing, Storage: -20 to 65°C (-4 to 149°F) non-freezing)
	Ambient Humidity	90% RH max. non-condensing Storage: 90% RH max. (non-condensing)
	Atmosphere	Indoors (no direct sunlight): no corrosive gas, inflammable gas, oil mist, dust or splash of oil/water)
	Elevation	1000m or less above sea level
	Vibration	When mounted on the surface AL 49m/s ² or less (direction of X, Y and Z axes) When mounted on surface B: 5.9m/s ² or less (directions of X, Y and Z axes)

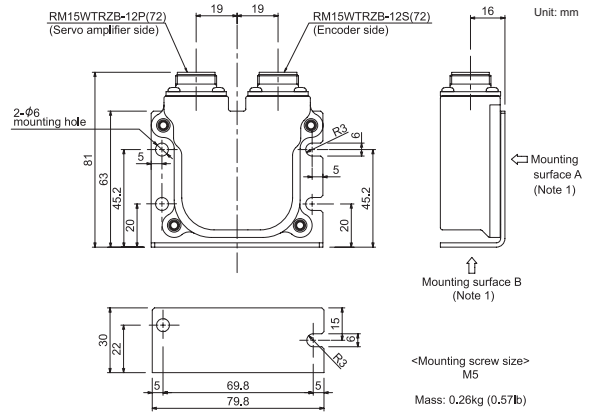

Optional Regeneration Resistors

Servo Amplifier	Built-in Regenerative Resistor/ (*1)	Tolerable Regenerative Power (W) (*3)						
		Optional Regeneration Unit (*1)						
		MR-RB032 (40Ω)	MR-RB12 (40Ω)	MR-RB30 (13Ω)	MR-RB31 (6.7Ω)	MR-RB32 (40Ω)	MR-RB50 (13Ω)(*2)	MR-RB51 (6Ω)(*2)
Stocked Item								
MR-J3-20B-RJ080W	10	30	100	-	-	-	-	-
MR-J3-40B-RJ080W	10	30	100	-	-	-	-	-
MR-J3-60B-RJ080W	10	30	100	-	-	-	-	-
MR-J3-70B-RJ080W	20	30	100	-	-	300	-	-
MR-J3-100B-RJ080W	20	30	100	-	-	300	-	-
MR-J3-350B-RJ080W	100	-	-	300	-	-	500	-
MR-J3-500B-RJ080W	130	-	-	-	300	-	-	500

Notes:

- For external dimensions and connections of the built-in regenerative resistor and optional regeneration unit, refer to MELSERVO-J3 catalog.
- Be sure to install a cooling fan. The cooling fan must be supplied by user.
- The power values in this table are resistor-regenerated powers, not rated powers.

TM-RFM002C20, TM-R FM004C20, TM-RFM006C20

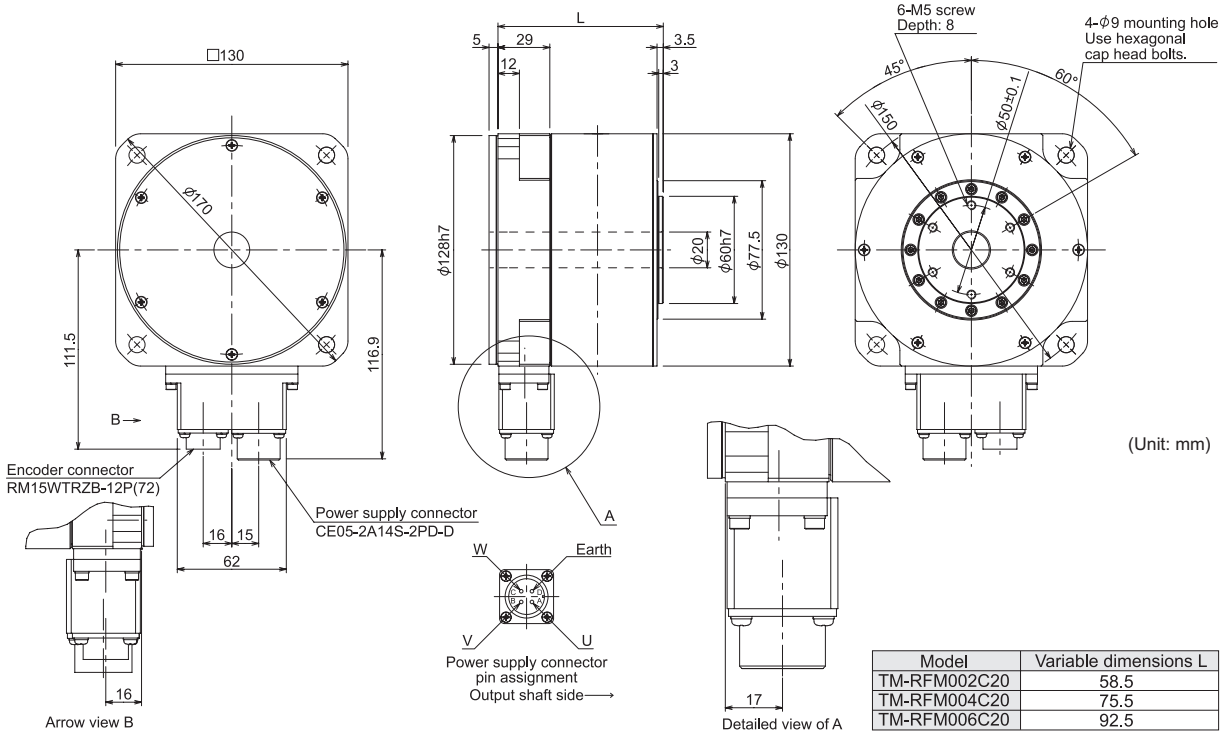

TM-RFM006E20, TM-RFM012E20, TM-RFM018E20

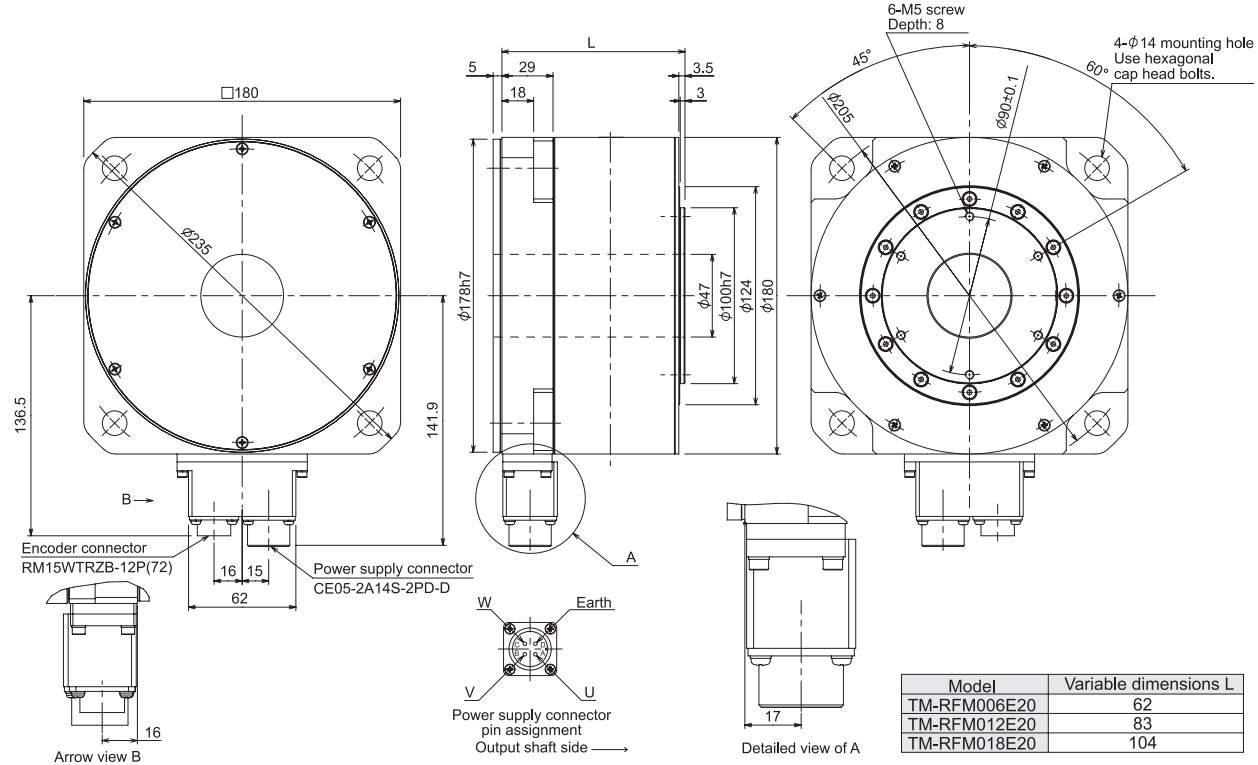

Note: For dimensions where there is no tolerance listed, use general tolerance. The actual dimensions may be 1 to 3mm larger than the dimensions

TM-RFM012G20, TM-RFM048G20, TM-RFM072G20

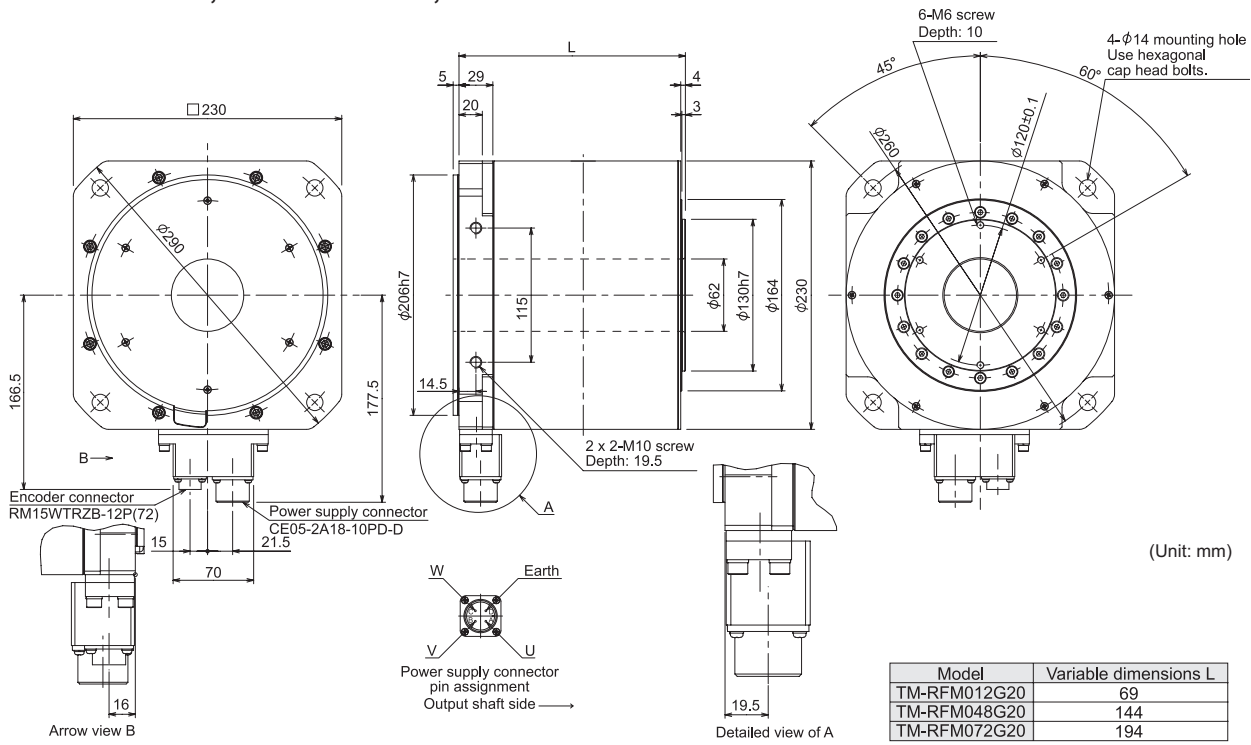

TM-RFM040J10, TM-RFM120J10, TM-RFM240J10

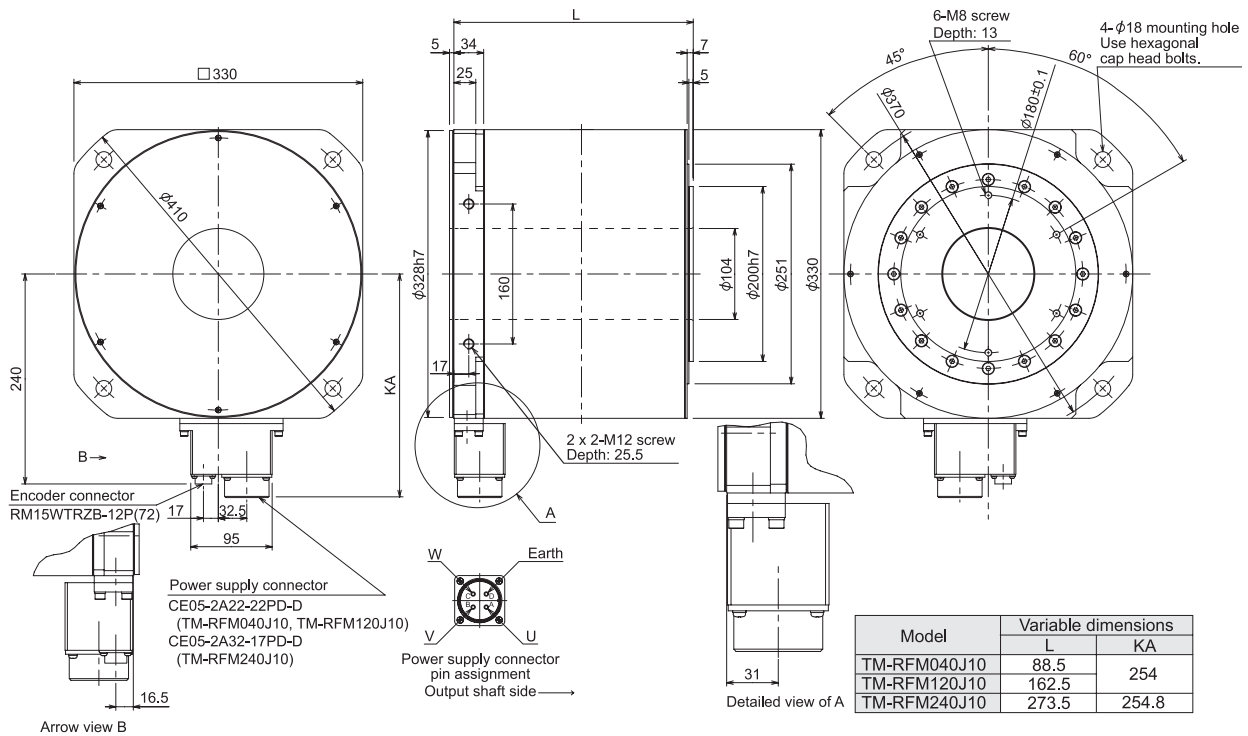

Note: For dimensions where there is no tolerance listed, use general tolerance. The actual dimensions may be 1 to 3mm larger than the dimensions listed. Make allowances for the tolerance when designing a machine.

